

Connectors for cable HJ8-50 (3")

Bulletin II-107554-EN

Figures show 3 1/8" IEC or EIA type connectors



CommScope Infrastructure Academy offers installation training.

M36270a

These instructions were written for qualified and experienced personnel. Please read them carefully before starting work. Any liability or responsibility for the results of improper or unsafe installation practices is disclaimed! Please respect valid environmental regulations for assembly and waste disposal!

Fig. 1

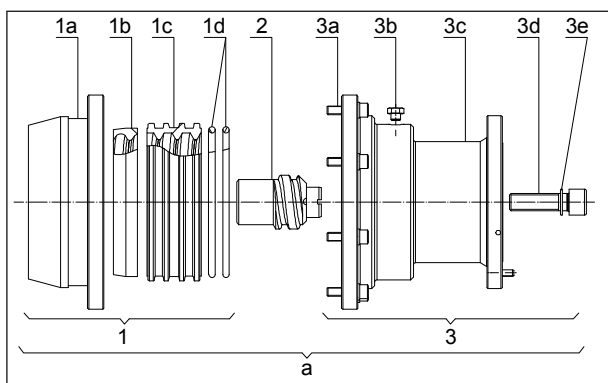

Fig. 2

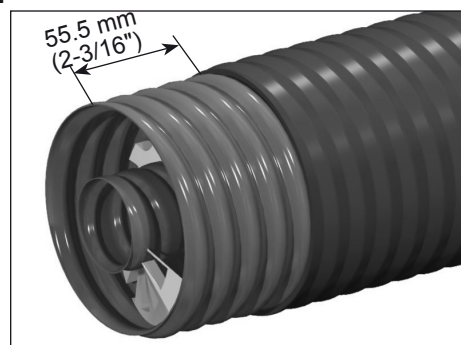

Fig. 3

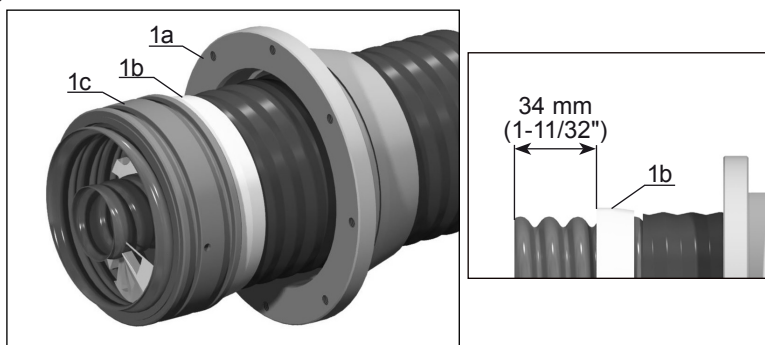
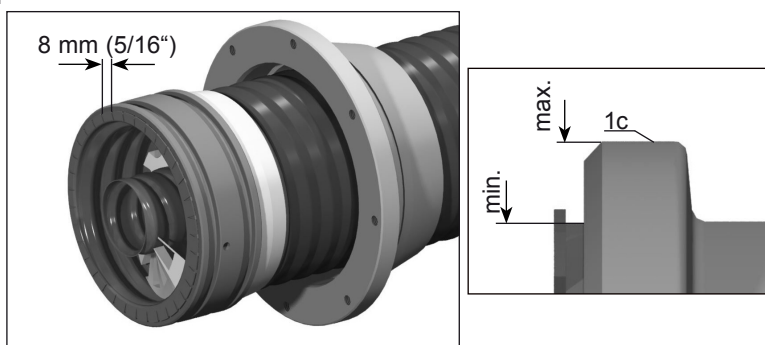

Fig. 4



Tools and Materials

Measuring tape (with mm graduations), cable knife, saw, flat file, flat pliers, metal shears, scraper, hexagon socket screw key size 6, 10, open-ended spanner 11 mm (7/16") for gas inlet cover, 3 mm (1/8") drill bit, hammer, plastic hammer or flaring rod (hard wood).

Connector disassembly, Fig. 1

- a) Disassembly of connector.
 - 1 Connector back end
 - 1a Fitting sleeve
 - 1b Sealing
 - 1c Clamping ring
 - 1d O-rings
 - 2 Screw unit (inner conductor)
 - 3 Connector head
 - 3a Hexagon screw (M8)
 - 3b Gas inlet screw (1/8" NPT)
 - 3c Connector outer conductor
 - 3d Hexagon screw (M10)
 - 3e Copper sealing

Cable trimming, Fig. 2

- b) Clean cable end and saw it off rectangular to cable axis.

Caution: Do not deform cable while trimming! Cut back cable jacket. Please observe that no metal particles get inside of the cable. It is recommended to seal the cable inside with a cloth temporarily. Deburr sawing edges! Remove all metal particles!

Preparing of outer conductor, Fig. 3

- c) Slide part (1a) over the cable.
- d) Screw part (1b) onto outer conductor close against jacket. Check smooth fit of part (1b) in the cable corrugation.
- e) Screw part (1c) against part (1b).

Flaring of outer conductor, Fig. 4

- f) Cut slits in the protruding outer conductor in axial direction until part (1c). The spacing of the slits shall be approx. 8 mm (5/16"). Flare outer conductor segments outwards against part (1c). Use flaring rod (hard wood). The flared cable outer conductor must be equally thick, if not it can be obtained by finishing this flared area with a file. The flared segments that exceed the diameter of part (1c) must be cut back with metal shears or flat file.

Fig. 5

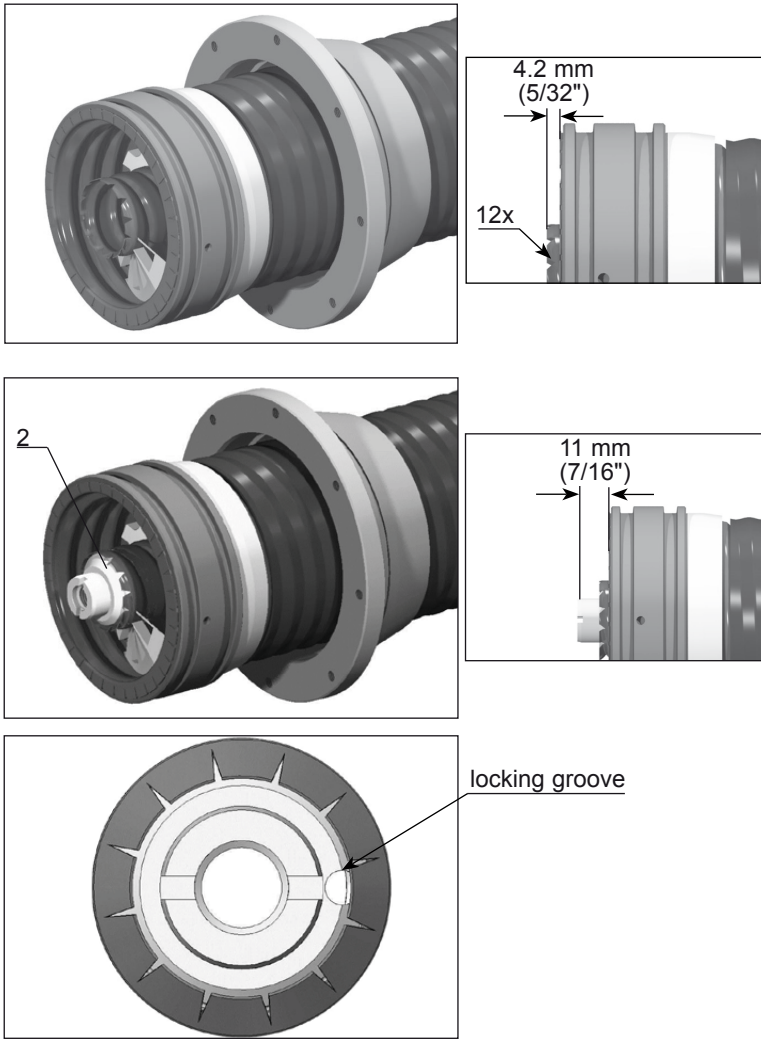

Flaring of inner conductor, Fig. 5

- g) Deburr inner conductor. Cut off protruding insulating helix even with outer conductor. Cut notches with metal shears (recommended: 12 notches).
Caution: Observe that the cloth has been removed after trimming!
- h) Screw part (2) into cable inner conductor. Adjust part (2) with mandrel \varnothing 3 mm (1/8") or screw driver.
- i) Push one jag of cable inner conductor into locking groove of part (2). Flare back cable inner conductor, making sure that part (2) does not change its position. The flared cable inner conductor must be equally thick, if not it can be obtained by finishing this flared area with a file. Overlaying tabs must be reworked. Remove protruding flaring edges.

Fig. 6

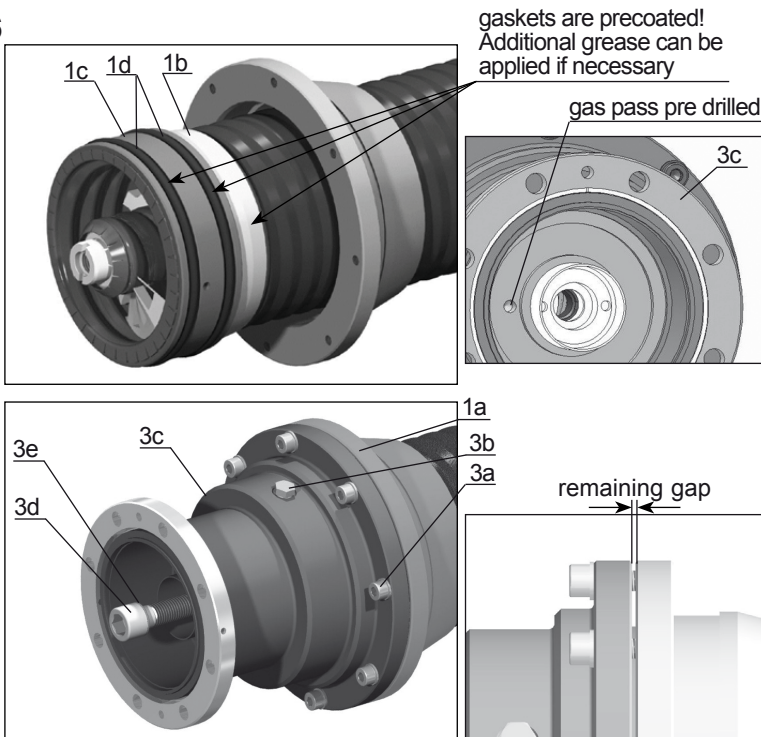

Fitting of connector head, Fig. 6

- j) If a gas pass connector is needed drill through pre drilled hole in the insulator with 6 mm (1/4") drill bit. Depending on connector interface the pre drill can be on front or back side of connector.
- k) Put parts (1d, 2x) into grooves of part (1c). Apply grease to part (1b) and parts (1d). Slide part (1a) onto part (1c). Slide part (3c) onto part (1c) of prepared cable end. Tightly and equally screw together part (3c) and part (1a) with hexagon socket screws parts (3a). Torque 17 Nm (12.5 ft.-lb.) approx. At correct installation a small gap will remain between part (1a) and part (3c).
- l) Screw up part (3d) and part (3e) with part (2). Torque 50 Nm (37 ft.-lb.) approx.
Note: In case of repeated assembly exchange the worn-out copper sealing part (3e) with the enclosed spare sealing.

Gas inlet (if required), Fig. 6

- m) Remove the part (3b) and install a suitable tube adapter.

Notice: CommScope disclaims any liability or responsibility for the results of improper or unsafe installation, inspection, maintenance, or removal practices.

部件名称/Component Name	有毒有害物质或元素/Toxic or Hazardous Substances and Elements					
	铅/Pb	汞/Hg	镉/Cd	六价铬/Cr 6+	多溴联苯/PBB	多溴二噁噻/PBDE
金属零件/metal parts	X	O	O	O	O	O

产品在正常使用条件下, 其环保使用期限才在此标识有效期内。 / The environmental protection use period is valid if the product is used as intended.