

L4E78-PS

7/8 in EIA Flange Positive Stop™ for 1/2 in LDF4-50A cable

Product Classification

Product Type	Wireless and radiating connector
Product Brand	HELIAX®
Product Series	LDF4-50A

General Specifications

Body Style	Straight
Cable Family	LDF4-50A
Inner Contact Attachment Method	Captivated
Inner Contact Plating	Silver
Interface	7/8 in EIA Flange
Mounting Angle	Straight
Outer Contact Attachment Method	Ring-flare
Outer Contact Plating	Trimetal
Pressurizable	No

Dimensions

Length	90.42 mm 3.56 in
Diameter	56.9 mm 2.24 in
Nominal Size	1/2 in

Outline Drawing

L4E78-PS

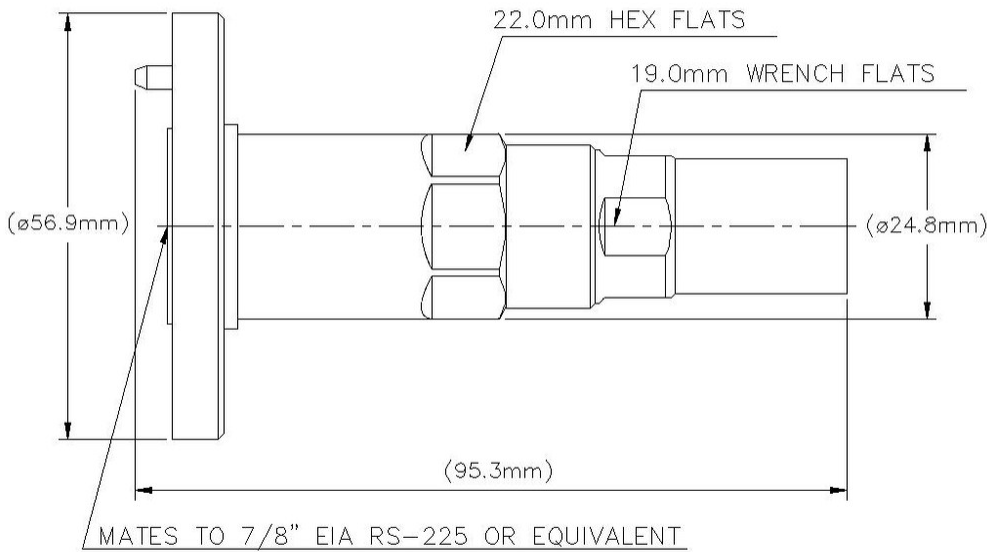

Electrical Specifications

Insertion Loss, typical	0.05 dB
Average Power at Frequency	2.3 kW @ 900 MHz
Cable Impedance	50 ohm
dc Test Voltage	6000 V
Inner Contact Resistance, maximum	1.5 mOhm
Insulation Resistance, minimum	5000 MOhm
Operating Frequency Band	0 – 5200 MHz
Outer Contact Resistance, maximum	1.5 mOhm
Peak Power, maximum	90 kW
RF Operating Voltage, maximum (vrms)	2120 V
Shielding Effectiveness	-110 dB

VSWR/Return Loss

Frequency Band	VSWR	Return Loss (dB)
45–1000 MHz	1.052	31.92
1010–2200 MHz	1.106	25.96

L4E78-PS

2210–3000 MHz	1.135	23.98
3010–4000 MHz	1.152	23.02
4010–5000 MHz	1.173	21.98
5010–7000 MHz	1.222	20.01
7010–8000 MHz	1.33	17
8010–8800 MHz	1.79	11

Mechanical Specifications

Attachment Durability	25 cycles
Connector Retention Tensile Force	889.64 N 200 lbf
Connector Retention Torque	8.14 N-m 72.001 in lb
Coupling Nut Proof Torque	24.86 N-m 220.003 in lb
Mechanical Shock Test Method	MIL-STD-202, Method 213, Test Condition I

Environmental Specifications

Operating Temperature	-55 °C to +85 °C (-67 °F to +185 °F)
Storage Temperature	-55 °C to +85 °C (-67 °F to +185 °F)
Attenuation, Ambient Temperature	20 °C 68 °F
Average Power, Ambient Temperature	40 °C 104 °F
Corrosion Test Method	MIL-STD-1344A, Method 1001.1, Test Condition A
Immersion Depth	1 m
Immersion Test Mating	Mated
Immersion Test Method	IEC 60529:2001, IP68
Moisture Resistance Test Method	MIL-STD-202, Method 106
Thermal Shock Test Method	MIL-STD-202F, Method 107G, Test Condition A-1, Low Temperature -55 °C
Vibration Test Method	MIL-STD-202, Method 204, Test Condition B
Water Jetting Test Mating	Mated
Water Jetting Test Method	IEC 60529:2001, IP66

Packaging and Weights

Weight, net	227.52 g 0.502 lb
--------------------	---------------------

Regulatory Compliance/Certifications

Agency	Classification
---------------	-----------------------

L4E78-PS

CHINA-ROHS	Below maximum concentration value
REACH-SVHC	Compliant as per SVHC revision on www.commscope.com/ProductCompliance
ROHS	Compliant



* Footnotes

Insertion Loss, typical 0.05√freq (GHz) (not applicable for elliptical waveguide)

Immersion Depth Immersion at specified depth for 24 hours