

---

# ***LIGHTNING*** **RADIO CONSOLE**

 *AUDIOARTS ENGINEERING*

TECHNICAL MANUAL  
June 2018



---

***LIGHTNING* Radio Console Technical Manual**

©2018 Audioarts® Engineering\*

AUDIOARTS ENGINEERING  
600 Industrial Drive  
New Bern, North Carolina 28562  
252-638-7000

\*a division of Wheatstone Corporation

---

# Attention!

## **Federal Communications Commission (FCC) Compliance Notice: Radio Frequency Notice**

**NOTE:** This equipment has been tested and found to comply with the limits for a Class A digital device, pursuant to Part 15 of the FCC rules. These limits are designed to provide reasonable protection against harmful interference when the equipment is operated in a commercial environment. This equipment generates, uses, and can radiate radio frequency energy and, if not installed and used in accordance with the instruction manual, may cause harmful interference to radio communications. Operation of this equipment in a residential area is likely to cause harmful interference in which case the user will be required to correct the interference at his own expense.



**This is a Class A product. In a domestic environment, this product may cause radio interference, in which case, the user may be required to take appropriate measures.**

This equipment must be installed and wired properly in order to assure compliance with FCC regulations.

**Caution! Any modifications not expressly approved in writing by Wheatstone could void the user's authority to operate this equipment.**

---

# Attention!

## IMPORTANT SAFETY INSTRUCTIONS

### THIS PRODUCT IS INTENDED FOR INDOOR USE ONLY

When using an electrical appliance, basic safety precautions should always be followed.

**DANGER** - To reduce risk of electric shock read all instructions before using this power supply. A power supply should never be left unattended when plugged in. Always unplug this power supply from the main socket immediately after using.

**WARNING** - To reduce risk of burns, fire, electric shock or injury to persons or animals:

1. Use this power supply only for its intended use as described below.
2. Do not use outdoors.
3. Do not allow to be used as a toy. Pay close attention when this power supply is used by, or near to, children.
4. Use only attachments recommended by the manufacturer.
5. Never operate this power supply if it has a damaged cord or plug, if it has been dropped or damaged or if it has fallen into water. In such cases return the power supply to an authorized dealer or service centre for examination or repair.
6. Never drop or insert an object into any openings.
7. Do not operate where aerosol (spray) products are being used or where oxygen is being administered.
8. This power supply should be used near to a convenient and easily accessible mains socket.

# ***LIGHTNING* Technical Manual**

## Table of Contents

### **Chapter 1 - Installation and Power**

<b>Console Overview .....</b>	<b>1-2</b>
<b>Unpacking and Installing the Console .....</b>	<b>1-3</b>
<b>Power Supply .....</b>	<b>1-4</b>
Failsafe Dual Redundant Supply .....	1-5
<b>Energizing .....</b>	<b>1-5</b>
<b>Audio and Control Wiring .....</b>	<b>1-6</b>
<b>Hook-Ups.....</b>	<b>1-8</b>
Audio Connections.....	1-8
Control Connections .....	1-10
Remote ON/OFF.....	1-11
External Start.....	1-11
On Air Tally .....	1-11
<b>Input Panel - Audio and Control Connections Drawing .....</b>	<b>1-12</b>
<b>Master Panel - Audio and Control Connections Drawing .....</b>	<b>1-13</b>
<b>Console Flow Diagram.....</b>	<b>1-14</b>

### **Chapter 2 - Controls and Functions**

<b>Input Panel .....</b>	<b>2-3</b>
Sources .....	2-3
USB Port .....	2-4
Using the USB Port.....	2-4
... With a MAC .....	2-4
... With a Windows® PC.....	2-4
Other Computers.....	2-4
General Considerations.....	2-5
Program Assign .....	2-5
CUE Button .....	2-5
Fader .....	2-5
Channel ON Switch .....	2-6
Channel OFF Switch .....	2-6
Mic Preamp Card .....	2-6
<b>Master Panel .....</b>	<b>2-7</b>
Callers .....	2-8
Taking a Caller Live to Air.....	2-8
Recording Calls .....	2-9

Control Room .....	2-9
Source Select .....	2-10
EXT Switch .....	2-10
SPLIT CUE .....	2-10
CONTROL ROOM Fader .....	2-10
HEADPHONE Fader .....	2-10
BLUETOOTH .....	2-11
Studio Control .....	2-12
Source Select .....	2-12
CUE Level Control .....	2-12
TB (Talkback) Button .....	2-12
STUDIO Level Control .....	2-12
TIMER Buttons .....	2-13
Meters .....	2-13
VU Meter Pairs .....	2-13
METER Select Button.....	2-13
On Air LED.....	2-13
<b>Console Programming Options .....</b>	<b>2-14</b>
Input Panel .....	2-14
Talkback .....	2-14
Mute CR .....	2-14
On Air Tally .....	2-14
Timer .....	2-14
Mic Preamp Card .....	2-15
Mic Selection.....	2-15
Phantom Power.....	2-15
Master Panel .....	2-15
Studio Dimn.....	2-15
Cue To Headphone.....	2-15
Cue To CR .....	2-15
Cue Mute.....	2-15
USB Source Selection.....	2-16

## Appendices

### Appendix 1

Installing the Additional Mic Preamp Card .....	A-3
---	-----

### Appendix 2

Replacement Parts List.....	A-5
-----------------------------	-----

# Installation and Power

## Chapter Contents

<b>Console Overview .....</b>	<b>1-2</b>
<b>Unpacking and Installing the Console .....</b>	<b>1-3</b>
<b>Power Supply .....</b>	<b>1-4</b>
Failsafe Dual Redundant Supply .....	1-5
<b>Energizing .....</b>	<b>1-5</b>
<b>Audio and Control Wiring .....</b>	<b>1-6</b>
<b>Hook-Ups.....</b>	<b>1-8</b>
Audio Connections.....	1-8
Control Connections .....	1-10
Remote ON/OFF.....	1-11
External Start.....	1-11
On Air Tally .....	1-11
<b>Input Panel - Audio and Control Connections Drawing.....</b>	<b>1-12</b>
<b>Master Panel - Audio and Control Connections Drawing .....</b>	<b>1-13</b>
<b>Console Flow Diagram.....</b>	<b>1-14</b>



## Installation and Power

### Console Overview

The mid-sized AUDIOARTS *LIGHTNING* console combines the best in a standalone console with the latest in modern conveniences such as USB and Bluetooth™ connectivity.

The *LIGHTNING* comes in 12- or 16-channel tabletop configurations and has a modular design with four channel Input panels, and a Master panel with linear faders for headphone and control room level control. All faders are conductive plastic and all switches are LED illuminated. Input channels have A/B source selection, with balanced line in for the A source and trimmable -10 to +4 line in on B.

Standard features include four stereo program buses, two auto mix-minuses for call-ins, four mic preamps with variable gain trim and switchable +48V phantom power, plus built-in headphone jack and CUE speaker. Additional four channel mic preamp card can be fitted if needed.

USB and Bluetooth connectivity onboard is useful for playing audio directly from a PC or to output audio to edit in VoxPro or other recording software, as well as receive and record calls from Bluetooth enabled cellphones or play cuts from MP3 players. The console also contains a patchable AES input for connecting a digital source to any fader, and built-in A/D conversion for the main program output so operators can access the Program Air feed as balanced analog, AES3 digital, or both simultaneously.



## Unpacking and Installing the Console

The AUDIOARTS *LIGHTNING* console is shipped as two packages. One carton contains the console and “Installation and Connections Quick Reference”; and the other contains the rackmount power supply, connecting cable, and connector kit. Remove packing materials and store them in the box for future use. Carefully place the console on your countertop (the *LIGHTNING* audio console is designed for countertop placement). The rubber feet on the bottom keep the console from being easily moved when simply placed on the counter.

**NOTE:**  
This console contains static-sensitive devices. Normal precautions against static discharge should be observed.

Avoid proximity to any electromagnetic fields, such as large power transformers, motors, and fluorescent lighting fixtures.

The console extends approximately 5-7/8" above the countertop at the meterbridge. The hinged meterbridge will require 7-1/7" above the countertop surface and 1" behind the rear meterbridge to open freely.

**Do not connect the *LIGHTNING* console to its power supply (and do not connect the power supply to the AC power line) until instructed to do so.**

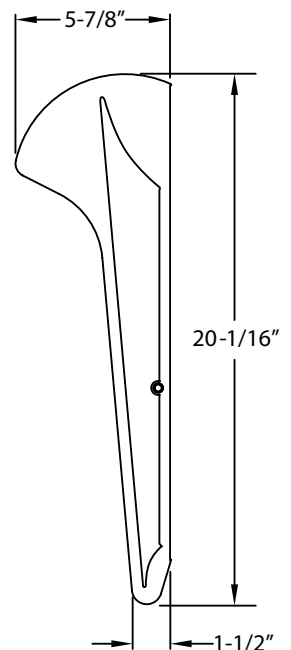
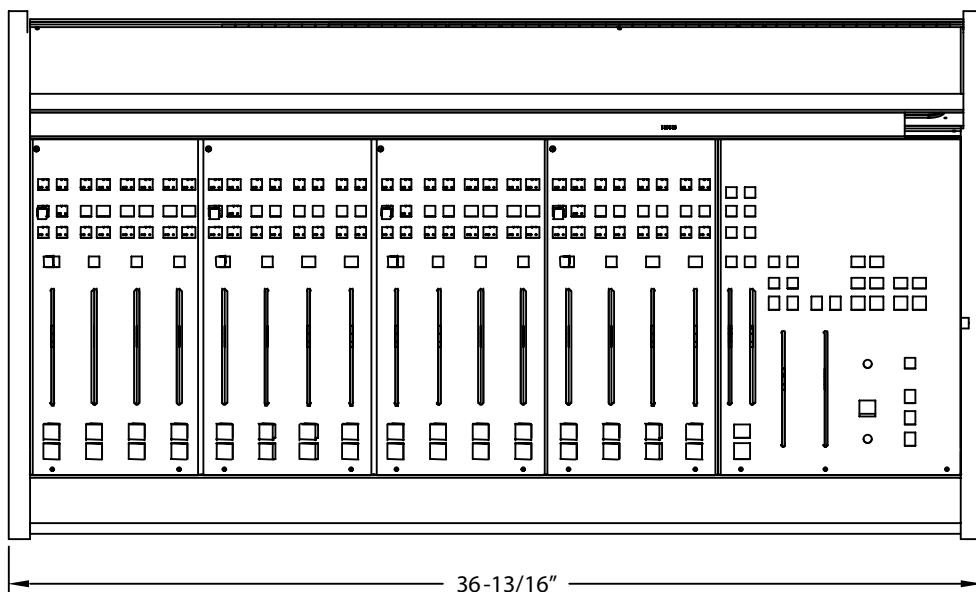
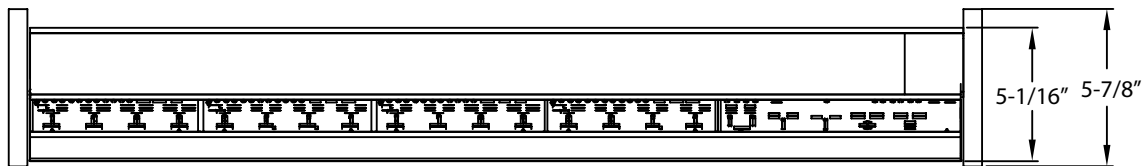

## Power Supply



Front view of the SPS-130 rackmount power supply

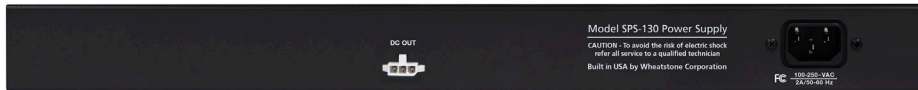

Rear view of the SPS-130 rackmount power supply

The *LIGHTNING* console is powered by an Audioarts Model SPS-130 rackmount power supply. This unit occupies a single 19" wide rack space. Convection cooled, it requires ample ventilation space above and below it. The SPS-130 generates heat in the course of normal operation.

Note the power supply (supplies) should be mounted in an equipment rack within fifteen feet of the console.

Once the supply is rackmounted, it should be connected to the console using the factory supplied 16' cable. The cable has a 3-Circuit Receptacle Housing on each end. The console's power supply 3-Circuit Header is located at the rear of the console, toward the left end of the meterbridge bottom pan when viewed from the rear of the console. In case of redundancy use two SPS-130 units. If you are using one supply, connect it to the console's connector. If you are using the failsafe option (two SPS-130 supplies), connect the long power supply cable to the center connector of the rackmount failsafe panel. Then connect one supply with a short cable to either of the two remaining connectors on the failsafe panel and connect the second supply with a short cable to the last connector.



### PS Cable Pinout

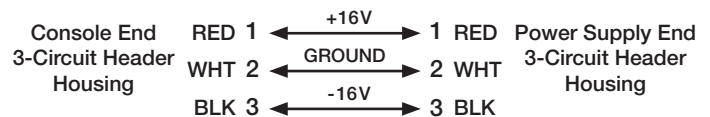

Note each power supply is fitted with a 3-wire grounded AC cord that should be plugged into a "clean" AC power source, that is, an AC source that feeds only the control room audio gear. This source should be a separate feed from those powering lighting, air-conditioning, or any other non-audio machinery. The third pin ground wire of the AC source should be tied to the central system ground point.

The power feed recommended in the text is often installed and referred to in studios as an "isolated AC ground" outlet. It is usually orange in color.

## Failsafe Dual Redundant Supply

Wheatstone failsafe power supply systems use two separate rackmount power supplies for each piece of powered equipment. Though either is capable of running a full load on its own, in failsafe operation both units run in tandem: if one fails, the other takes over, assuring uninterrupted operation.

In order for failsafe systems to perform as designed, always have BOTH rackmount supplies powered up and connected to their associated equipment.

## Energizing

Assuming the *LIGHTNING* console mainframe is properly placed, and its SPS-130 power supply (or supplies) correctly rackmounted and connected to the console, you may now energize the rackmount power supply by plugging it into the AC mains. The “POWER” LED on the power supply front panel should light up to indicate the presence of the voltage. The console’s switches will assume factory default settings.

**NOTE:** To de-energize the control surface, unplug the rackmount power supply’s AC cord from the AC mains. *Never de-energize the console by disconnecting the cable that connects the console and power supply together.*

---

**Once you have verified proper power-up, unplug the rackmount power supply to de-energize the console. You may now proceed to wire up audio and control connections.**

---

## Audio and Control Wiring

All audio I/O connections are made via RJ-45 and USB connectors on the rear panel of the console and 3-position plug terminals on the Mic Preamp card.

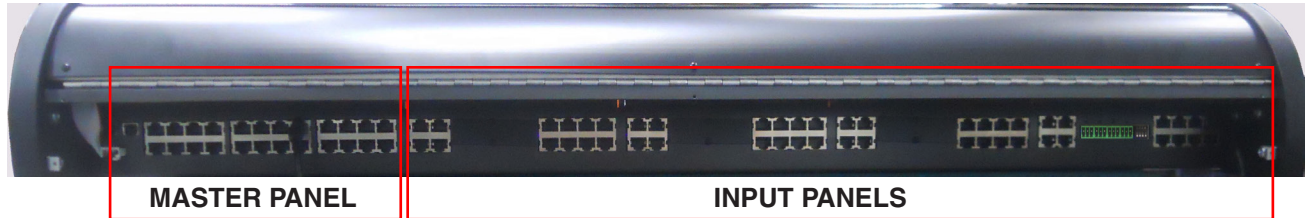

Input panel's eight RJ-45 are line level stereo inputs for A and B channels.

A four mic preamp card is for mono mic level signals via four 3-position plug terminals to feed internal adjustable preamps that feed Input panel's A channel.

Four Logic I/O RJ-45 provide logic inputs and outputs for Remote ON/OFF and External Start.

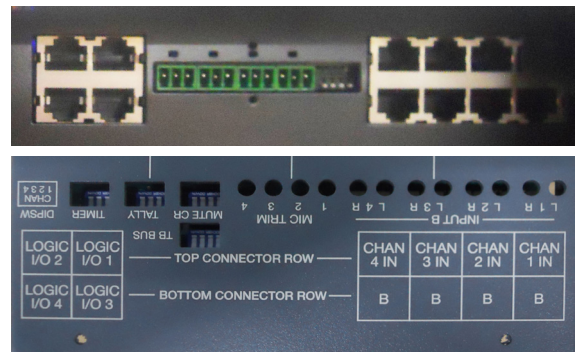

These connectors are for Master panel:

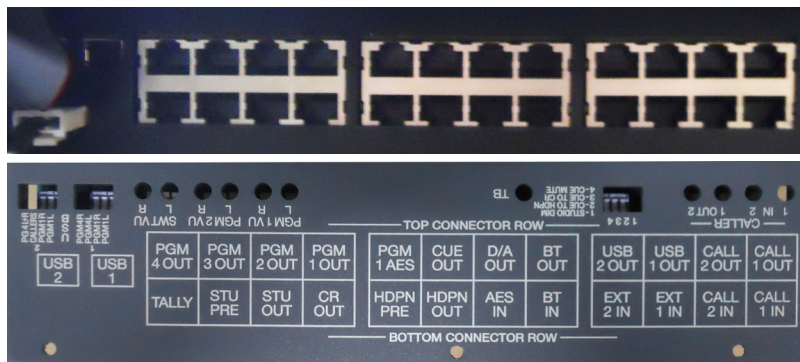

Two RJ-45 CALL 1, 2 IN are mono line level inputs that are controlled by CALLER faders.

Two RJ-45 CALL 1, 2 OUT are mono line level post fader summed trimmed outputs.

Two RJ-45 USB 1, 2 OUT are unbalanced line level stereo outputs.

Two RJ-45 EXT 1, 2 IN are balanced stereo line level inputs that feeds the monitor circuits when EXT is selected.

BT IN/BT OUT RJ-45 is an unbalanced line level stereo input/output for Bluetooth connectivity. Bluetooth output may be connected to any of the console's line level inputs using a RJ-45 straight cable.

Digital source plugs into the AES IN RJ-45, passes through built-in A/D converter, and feeds an Input panel's fader by patching the D/A OUT RJ-45 connector to any of the inputs channel's RJ-45 using a RJ-45 straight cable.

RJ-45 CUE OUT is a balanced mono line level CUE output.

RJ-45 PGM1 AES is digital Program 1 output.

RJ-45 HDPN OUT and HDPN PRE are balanced line level stereo post and pre fader outputs.

Four PGM 1-4 OUT RJ-45 are balanced line level stereo Program 1-4 outputs.

RJ-45 CR OUT is balanced line level stereo Control Room output.

RJ-45 STU OUT and STU PRE are balanced line level stereo post and pre fader Studio outputs.

RJ-45 TALLY is provided to hook up an interface to an Air Tally light. This output comes from a set of relay contacts and is designed to switch a low DC voltage (30 VDC maximum) at a moderately low current (2 ADC maximum) to activate a DC light, or to activate an external DC relay which can then be used to activate an AC operated light. Never bring AC power into the console on this or any other connector.

Two USB type B connectors are provided to bring in and send audio through a USB connection to a computer.

A 3-Circuit Header is provided to accept console power from the external power supply.

One TRS jack is provided on the right side of the console frame for the operator to plug in a set of headphones. This is wired as a standard headphone jack, with the left signal on the tip, the right signal on the ring, and the sleeve connected to ground.

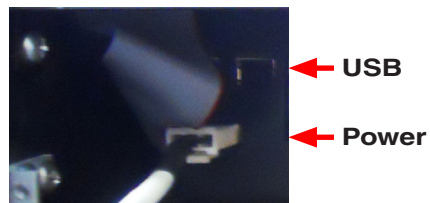

## Hook-Ups

The rear of the console has multiple RJ-45 connectors to plug in stereo line inputs, the external inputs, caller connections to and from hybrid, a Bluetooth connection, as well as providing studios, control room, microphones, PGM, and USB analog output connections.

A four mic preamp card is available for mono mic level signals via four 3-position plug terminals.

Two USB port with type B connectors available for interfacing with a computer (see page 2-4 for details).

Pinouts drawings on pages 1-12 and 1-13 show all wiring connection at glance.

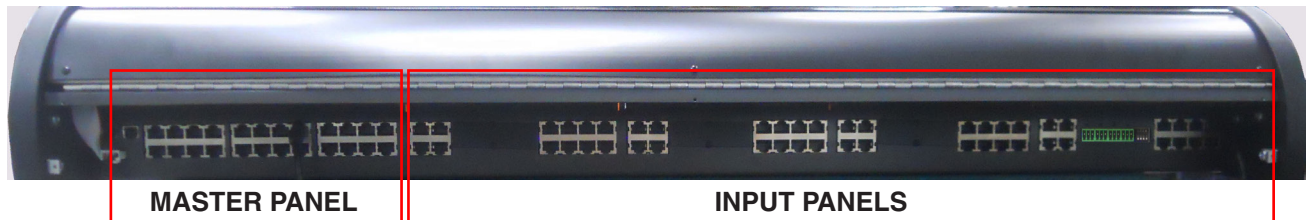

## Audio Connections

### Analog Stereo Inputs – RJ-45 (Input Panel)

The signals are analog stereo; balanced.

Pin 1 – HI	]	LINE INPUT LT
Pin 2 – LO		
Pin 3 – HI	]	LINE INPUT RT
Pin 6 – LO		

### MIC 1 - MIC 4 Inputs – 3-position Plug Terminal

All signals are analog mono. The mic input level is normally -50dBu balanced.

Pin 1 – SH	]	MIC IN
Pin 2 – LO		
Pin 3 – HI		

These connections are to the inputs of four internal mic preamplifiers. The outputs of the MIC1-MIC4 preamplifier are internally wired to the Input dipswitch. See page 2-15 for details.

### Caller 1 & 2 In/Out – RJ-45

Signals is analog mono; balanced.

Pin 1 – HI	]	CALLER IN
Pin 2 – LO		

Pin 1 – HI	]	CALLER OUT
Pin 2 – LO		

### EXT 1 & 2 Input – RJ-45

Signals is analog stereo; balanced.

Pin 1 – HI	]	EXT LT IN
Pin 2 – LO		
Pin 3 – HI	]	EXT RT IN
Pin 6 – LO		

### USB 1 & 2 Out – RJ-45

The signals are analog stereo; unbalanced.

Pin 1 – HI	]	USB LT OUT
Pin 2 – SH		
Pin 3 – HI	]	USB RT OUT
Pin 6 – SH		

### Headphone Out – RJ-45

The signals are analog stereo; balanced.

Pin 1 – HI	]	HDPN PRE LT OUT
Pin 2 – LO		
Pin 3 – HI	]	HDPN PRE RT OUT
Pin 6 – LO		

Pin 1 – HI	]	HDPN LT OUT
Pin 2 – LO		
Pin 3 – HI	]	HDPN RT OUT
Pin 6 – LO		

### Digital In – RJ-45

The signal is AES digital.

Pin 1 – HI	]	AES IN
Pin 2 – LO		

### D/A Out – RJ-45

The signal is analog stereo; balanced.

Pin 1 – HI	]	LINE LT OUT
Pin 2 – LO		
Pin 3 – HI	]	LINE RT OUT
Pin 6 – LO		

### Bluetooth In/Out – RJ-45

The signals are analog stereo; unbalanced.

Pin 1 – HI	]	BT LT IN
Pin 2 – SH		
Pin 3 – HI	]	BT RT IN
Pin 6 – SH		

Pin 1 – HI	]	BT LT OUT
Pin 2 – SH		
Pin 3 – HI	]	BT RT OUT
Pin 6 – SH		

### CUE Out – RJ-45

Signals is analog mono; balanced.

Pin 1 – HI     ] CUE OUT  
Pin 2 – LO     ]

### PGM Out – RJ-45

The four PGM 1 - PGM4 analog stereo balanced program outputs and one PGM 1 AES digital output.

Pin 1 – HI     ] PGM LT OUT  
Pin 2 – LO     ]  
Pin 3 – HI     ] PGM RT OUT  
Pin 6 – LO     ]

Pin 1 – HI     ] PGM 1 AES OUT  
Pin 2 – LO     ]

### Control Room Out – RJ-45

The signal is analog stereo; balanced.

Pin 1 – HI     ] CR LT OUT  
Pin 2 – LO     ]  
Pin 3 – HI     ] CR RT OUT  
Pin 6 – LO     ]

### Studio Out – RJ-45

The signals are analog stereo; balanced.

Pin 1 – HI     ] STU LT OUT  
Pin 2 – LO     ]  
Pin 3 – HI     ] STU RT OUT  
Pin 6 – LO     ]  
Pin 1 – HI     ] STU PRE LT OUT  
Pin 2 – LO     ]  
Pin 3 – HI     ] STU PRE RT OUT  
Pin 6 – LO     ]

### Control Connections

Functions include remote on and off, tally, and start/stop for remote source machines. The Start, Stop, Tally ON, and Tally OFF ports are opto-isolated.

#### 1 - 4 Logic I/O – RJ-45

RJ-45 Pin 1 – Digital Ground  
RJ-45 Pin 2 – Start  
RJ-45 Pin 6 – Remote OFF  
RJ-45 Pin 7 – Remote ON  
RJ-45 Pin 8 – +5V Digital



## TALLY – RJ-45

RJ-45 Pin 1 – On Air Tally N.O.

RJ-45 Pin 2 – On Air Tally Com

## Remote ON/OFF

“Remote location” can also refer to a remote source machine that is feeding its audio to the module in question. A contact closure (which may be sourced by the external machine), will activate the module’s channel ON and OFF switches.

To turn the module ON and OFF from remote locations make following connections:

REMOTE ON – Momentarily connect Logic RJ-45 Pin 7 (Remote ON) and Digital Ground (Pin 1) to latch the module ON. (User-supplied momentary contact switch required.)

REMOTE OFF – Momentarily connect Logic RJ-45 Pin 6 (Remote OFF) and Digital Ground (Pin 1) to latch the module OFF. (User-supplied momentary contact switch required.)

## External Start

To Start remote source machines using ON/OFF switches make the following connections:

EXTERNAL START – Hook up the remote machine’s “start” control pins to the Logic RJ-45 connector Pin 2 (Start) and Pin 1 (Digital Ground).

## On Air Tally

Lets any programmed channel’s ON switch control an on-air light or other “microphone on” indicator at a remote location. This control function provides a contact closure between Pin 1 (On Air Tally N.O.) and Pin 2 (On Air Tally Common) of the TALLY RJ-45 whenever the channel is ON.

This signal can be used to control an externally powered tally light that requires a continuous closure to function. *Current should not exceed 2 amps at 30 volts DC.*

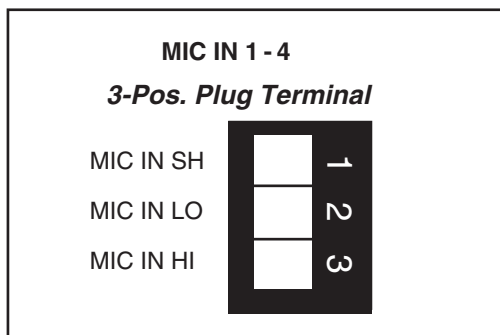
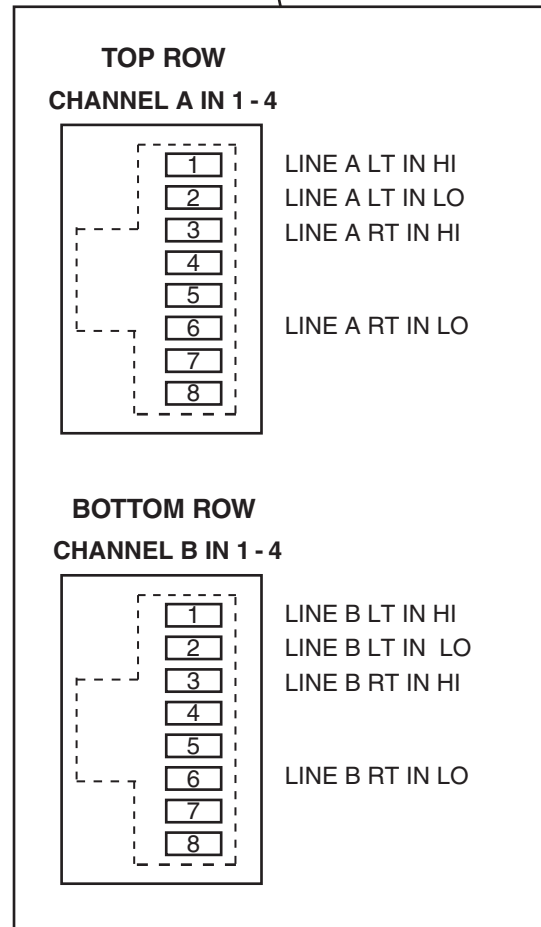
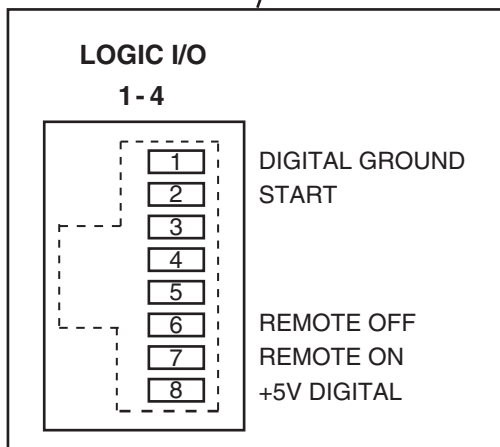
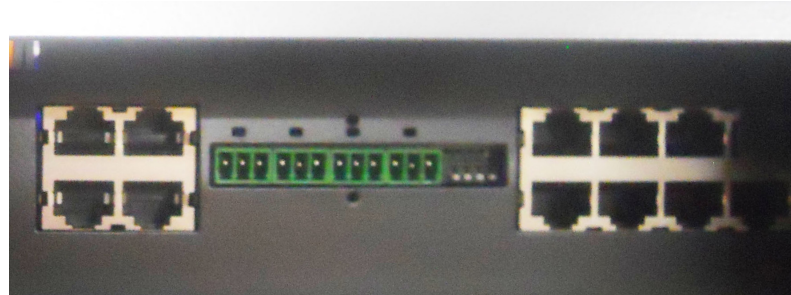
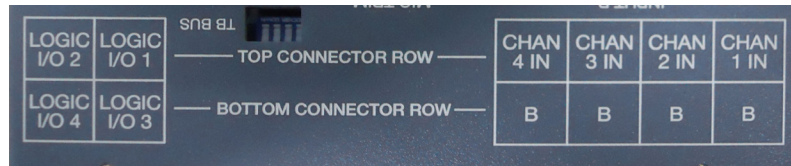

Input Panel - Audio and Control Connections

USB PORTS

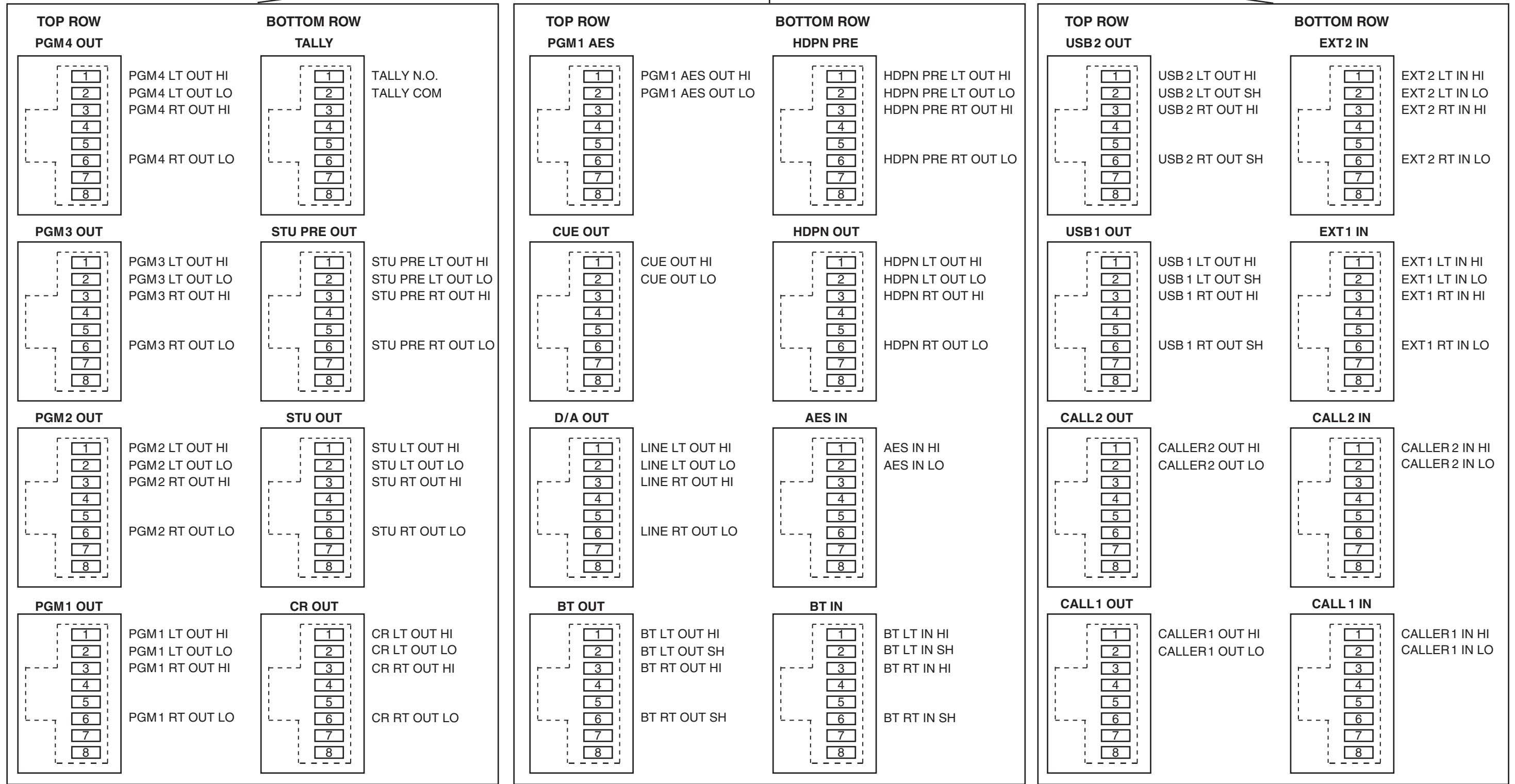
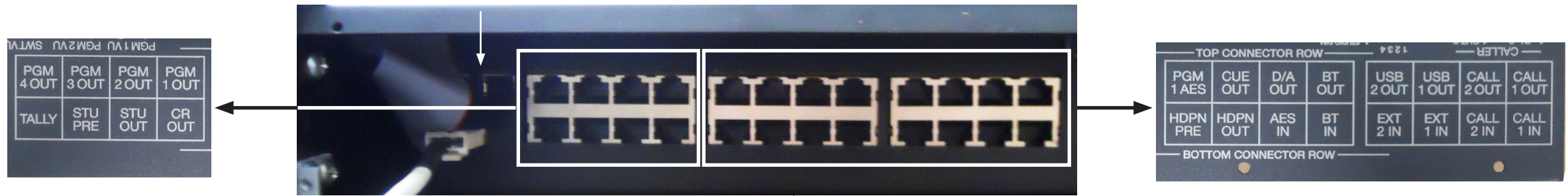

Master Panel - Audio and Control Connections

LOGIC ACNS

MONITORS

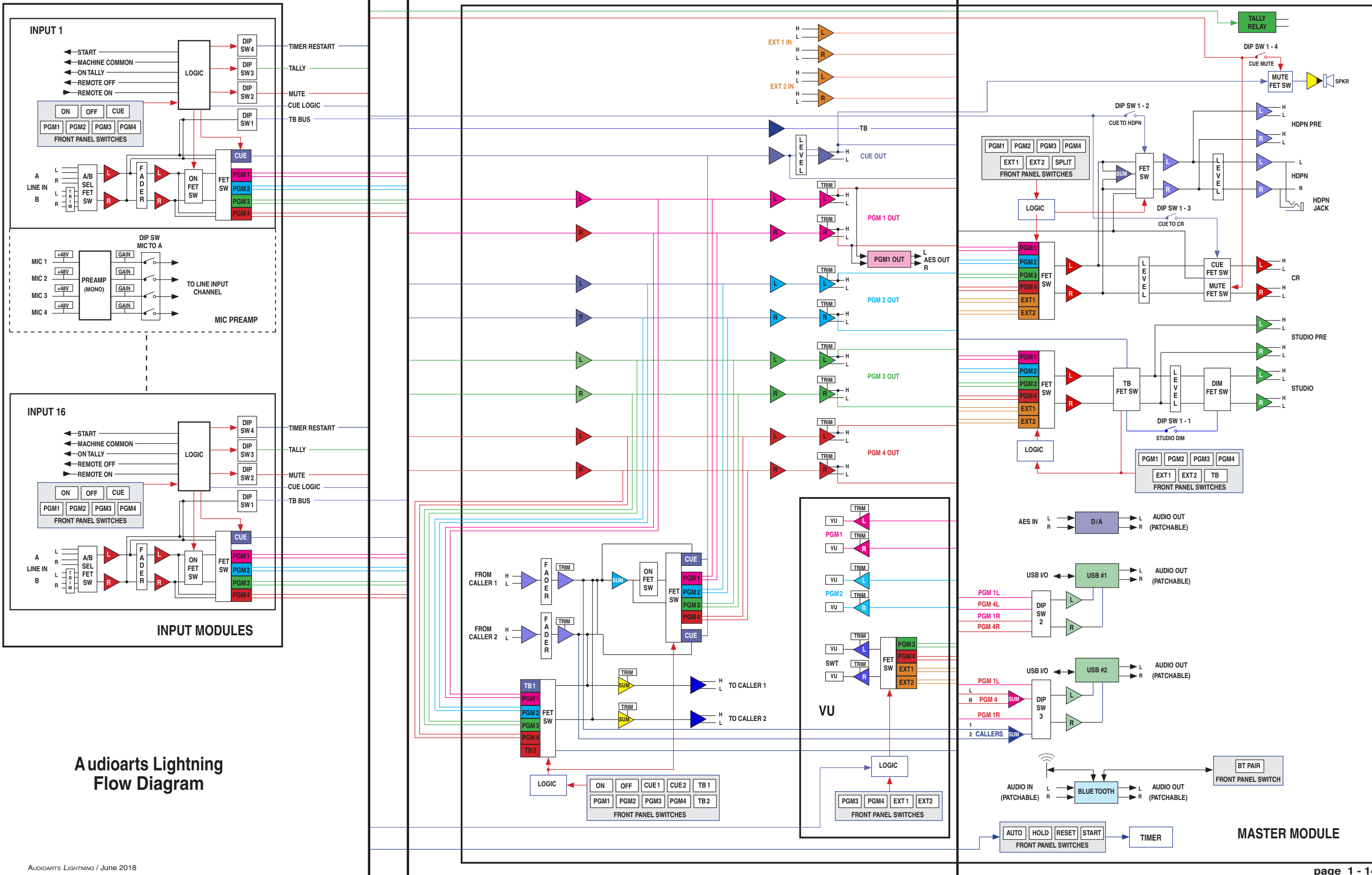

Audioarts Lightning Flow Diagram

# Controls and Functions

## Chapter Contents

<b>Input Panel .....</b>	<b>2-3</b>
Sources .....	2-3
USB Port .....	2-4
Using the USB Port.....	2-4
... With a MAC .....	2-4
... With a Windows® PC .....	2-4
Other Computers.....	2-4
General Considerations.....	2-5
Program Assign .....	2-5
CUE Button .....	2-5
Fader .....	2-5
Channel ON Switch .....	2-6
Channel OFF Switch .....	2-6
Mic Preamp Card .....	2-6
<b>Master Panel .....</b>	<b>2-7</b>
Callers .....	2-8
Taking a Caller Live to Air .....	2-8
Recording Calls .....	2-9
Control Room .....	2-9
Source Select .....	2-10
EXT Switch .....	2-10
SPLIT CUE .....	2-10
CONTROL ROOM Fader .....	2-10
HEADPHONE Fader .....	2-10
BLUETOOTH .....	2-11
Studio Control .....	2-12
Source Select .....	2-12
CUE Level Control.....	2-12
TB (Talkback) Button .....	2-12
STUDIO Level Control .....	2-12
TIMER Buttons .....	2-13
Meters .....	2-13
VU Meter Pairs .....	2-13
METER Select Button.....	2-13
On Air LED.....	2-13
<b>Console Programming Options .....</b>	<b>2-14</b>
Input Panel .....	2-14
Talkback .....	2-14
Mute CR .....	2-14
On Air Tally .....	2-14
Timer .....	2-14
Mic Preamp Card .....	2-15
Mic Selection.....	2-15
Phantom Power.....	2-15

Master Panel .....2-15  
  Studio Dimn.....2-15  
  Cue To Headphone.....2-15  
  Cue To CR .....2-15  
  Cue Mute.....2-15  
  USB Source Selection.....2-16

# Controls and Functions

## Input Panel

Each Input panel of the *LIGHTNING* console has four identical input strips.

### Sources

Input channels have A/B source selection, with balanced line in for the A source and trimmable -10 to +4 line in on B.

Recessed front panel trimpots, located underneath the hinged meterbridge, adjust the left and right levels of the B source.

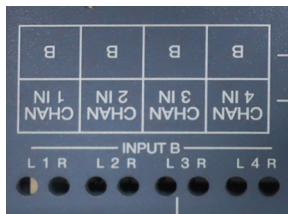

The *LIGHTNING* console is designed to handle up to 16 analog stereo line inputs. These inputs are typically used to connect to machines, such as tape decks, cart machines, CD players, etc., that provide analog outputs.

The console also contains a patchable AES input for connecting a digital source to any fader, and built-in A/D conversion for the main program output so operators can access the Program air feed as balanced analog, AES3 digital, or both simultaneously.

Additional four channel mic preamp card can be fitted if needed.



## USB Port

The *LIGHTNING* console contains USB 2.0 interface, available via two USB Type B connectors located underneath the hinged meterbridge, to enable audio to pass between the console and a USB port on a computer. The audio from the console to the computer is selectable via two dipswitches (described in the “Console Internal Programming” section). Audio coming back from the computer via USB shows up as a stereo analog signal on any input fader by using a RJ-45 straight patch cable between USB OUT and desired input channel.

### Using the USB Port . . .

Any computer having a USB port and installed drivers capable of passing and utilizing digital audio data should work with the *LIGHTNING* USB ports. Use a cable having a USB Type B connector on the *LIGHTNING* end and a connector on the other end that will mate with the computer’s USB port; this will typically be a USB Type A connector.

#### . . . With a MAC

In general, this will be a plug-and-play process. The main concern is to choose the USB Audio Codec under *System Preferences>Sound* as desired for audio input and/or output. Then simply start the application.

#### . . . With a Windows® PC

When you first connect the *LIGHTNING* USB port to a PC running Windows you will see the famous “found new hardware” sequence of messages. At some point this sequence should end with a message that the new hardware is installed and ready to use.

Setting up any given application to use the *LIGHTNING* USB ports will depend on the application itself. Generally, you will need to select the appropriate device from a list of devices in a Preferences dialog.

As an example, let’s look at Audacity. Audacity is a free, easy-to-use, multi-track audio editor and recorder for Windows, Mac OS X, GNU/Linux and other operating systems. It allows you to easily select audio inputs and outputs.

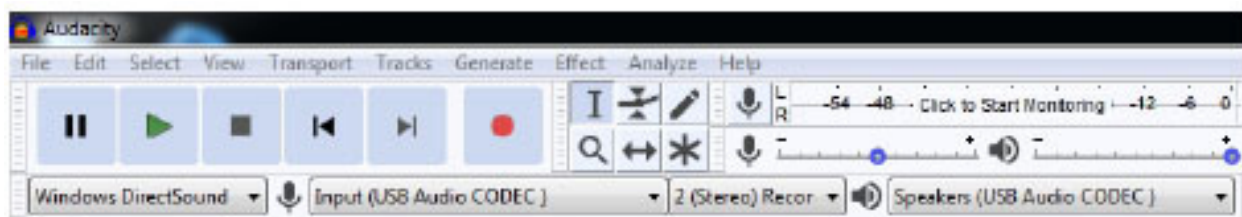

Select the USB Audio CODEC for input and output. You will be able to record audio from the *LIGHTNING* console and when you play it back, the audio will appear at the USB OUT connector on the console.

### Other Computers

If your computer does not use one of the above operating systems, or otherwise behaves differently than described above, consult the documentation for that computer, operating system, and/or application.



## General Considerations

If any problems are encountered, please consider the following points:

- If you are not able to get the audio into or out of the USB port, check the USB cable, its connections at both ends, and the port selection settings in the application you are using.
- If you have the audio flowing where you want and it suddenly becomes intermittent or disappears, check the USB cable and the connections at both ends.
- Once you have the USB audio under control it is a good idea to make a record of the application being used, including its version number, the audio direction (into or out of the computer), and all the settings that were required to make it work. This information will be invaluable if you later have to troubleshoot the USB audio, or set it up on another computer.

## Program Assign

Output switches assign the selected source signal to any combination of the console's four stereo Program outputs – PGM 1 - PGM 4. The button will be lit when the source is assigned to its respective bus. To remove a source from the bus, press the button again; the light will go off to indicate that the source is no longer assigned to that bus.

The four Program outputs operate the same: the audio from the channel connects to the assigned PGM bus post-fader and post-channel ON switch. In other words, to hear the channel's audio on a program bus the channel must be assigned to that bus (the desired PGM button must be lit), the channel must be turned on (the ON button must be lit), and the fader must be adjusted to control the level of the channel audio going to the selected PGM bus.

Recessed front Master panel trimpots adjust the left and right levels of PGM 1 and PGM 2 VU meters.



## CUE Button

A CUE switch places the channel's signal on the console's cue bus, where it may be heard on the meterbridge mounted cue speaker, as an interrupt to the console operator's headphones, and as an interrupt to the control room monitor speakers, if so programmed.

Press the CUE button. The channel's input signal will be included in the console's CUE output at a level that is independent of the fader setting, and the button will light. The fader does not need to be turned ON. To remove a fader from cue, press the CUE button again; the light will go off to indicate the channel is no longer assigned to cue.

## Fader

Level is set by a long-throw fader. The fader is the sliding mechanism that determines how strong is the presence of the input in some of the various console outputs.

If the fader is all the way down (that is, pulled toward the console operator), the signal will not be present in either of the two program main buses to which it is assigned. As the fader is moved up (that is, pushed away from the console operator) the signal will appear more strongly in each of the main buses to which it is assigned.

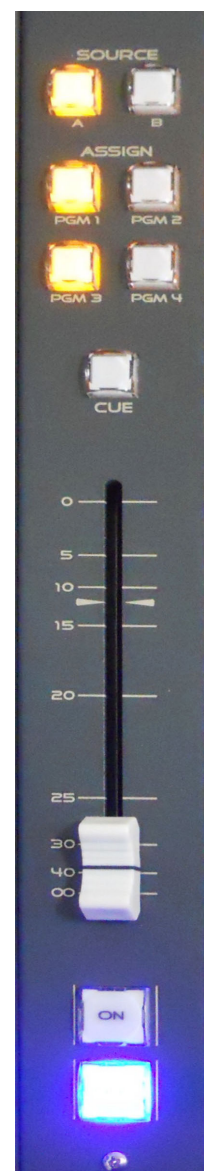

## Channel ON Switch

The channel ON switch turns the channel signal ON and fires any channel ON (START) logic mapped to the fader's source signal. The switch LED lights to indicate the channel is ON and the ON AIR LED will light on the left upper corner of the meterbridge if so programmed (see the discussion of OnAir Tallies in the "Console Internal Programming" section).

## Channel OFF Switch

The channel OFF switch turns the channel signal OFF. The switch LED lights to indicate the channel is OFF.

## A Mic Preamp Card\*

A four channel microphone preamplifier card is fitted if needed for analog mono mic level inputs that used to connect to microphones, which typically put out signals at relatively low signal strength, and therefore require more amplification (increase in signal strength) to be properly audible in the output. Mic level sources are plugged into the four 3-pin headers located on the Mic Preamp card. Recessed front panel multi-turn trimpots, located underneath the hinged meterbridge, are for adjusting the level of each microphone input independently.



Example: With a microphone input of  $-60\text{dBm}$  @  $150\text{ohm}$  at the port, gain trim can set levels from  $-22\text{dBu}$  to  $+16\text{dBu}$  (note maximum preamp gain is  $+76\text{dB}$ ) at the PGM outputs.

The microphone preamplifiers are internally wired to the Input dipswitch that can be programmed to feed the A source to the fader where you will control the microphone levels (described below in the "Console Programming Options" section).

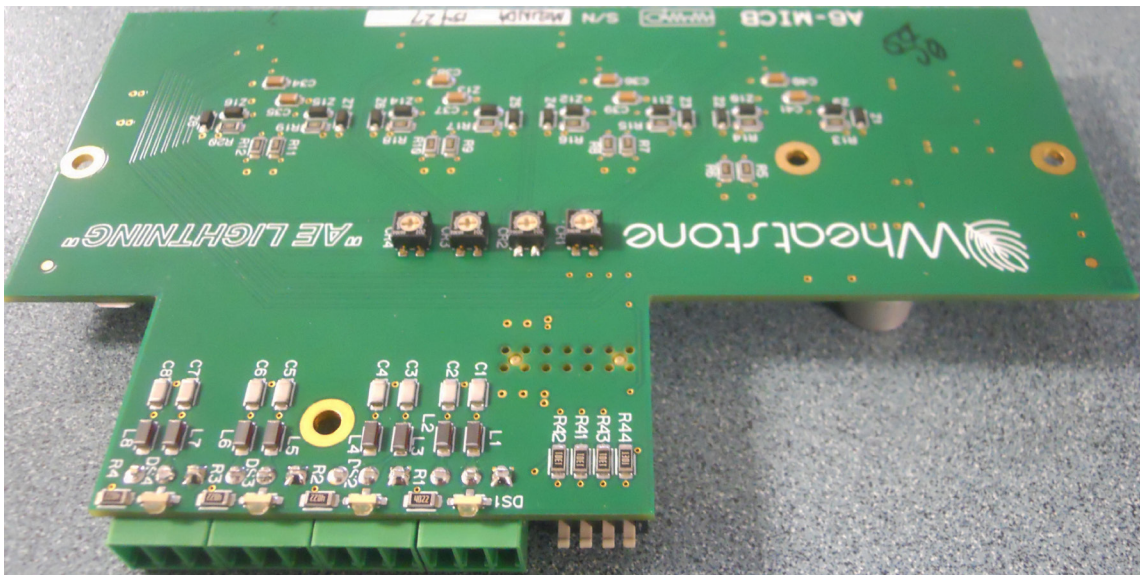

\*One is standard, additional cards are available as options.

## Master Panel

The Master panel includes the Caller Input, Control Room monitor, Studio monitor, and Meters sections.



## Callers

This section of the monitor panel contains the controls for two phone hybrids or an IP phone system with analog connections. Phone systems have two audio signals: a “From Network” signal which connects from the phone system to the Caller 1 and/or Caller 2 Inputs, and a “To Network” signal which connects a mix-minus signal from the Caller 1 and/or Caller 2 outputs back to the phone system.

Each phone input (labeled CALLER 1 and CALLER 2) has independent fader level control along with its own Cue (CUE 1 and CUE 2) and Talkback (TB 1 and TB 2) buttons. The two Callers have common ON/OFF buttons and PGM bus assignment buttons.

Only one PGM bus can be selected for the callers since the selection both assigns the callers to the selected PGM bus and sends that PGM bus’ mix-minus audio back to both callers (the PGM bus mix-minus audio signal is derived prior to the callers’ audio being summed into that PGM bus). Also, the caller 1 audio is summed into caller 2’s output, and vice versa, so the two callers can hear one another as well as the PGM bus mix-minus audio.

Because the two callers have a common ON/OFF control, both Caller 1 and Caller 2 will feed the assigned bus when the On button is lit. If you have one caller live while answering a second call, the caller faders must be used to control which caller is feeding the assigned PGM bus. For example, if Caller 1 is live then the Caller 2 fader must be fully down (set to  $\infty$ ). The Cue 2 button would be lit so the board operator can hear the second caller. To talk to the caller, the board operator would press/hold the TB 2 button. To talk to the caller that’s on-air the board operator would press the TB 1 button.

**NOTE:** On each fader channel, setup switch 1 assigns one channel to feed the talkback bus. Typically, only the board operator mic channel is set for talkback. The talkback audio is derived pre-fader and pre-switch.

Four recessed trim pots (located below the hinged meter bridge) adjust the incoming audio levels for Caller 1 and Caller 2 and adjust the outgoing levels of the mix-minus audio going to the Caller 1 and Caller 2 outputs.



### Taking a Caller Live to Air

If Caller 1 will go live to Air, the Callers channel is assigned to the bus feeding air (typically PGM 1). Turn on Cue 1 so that the caller feeds cue. The Caller 1 fader is potted up and the Caller 2 fader is potted full off. To talk to the caller, the board operator press/holds the TB 1 button while talking. When the TB 1 button is not pressed the caller hears PGM 1.

To add the caller to the PGM 1 mix, turn On the Callers channel and adjust the Caller 1 fader as necessary. If the board operator needs to talk to the caller they would again use the TB 1 button to talk.

**NOTE:** Pressing TB 1 cuts off the PGM mix-minus audio to the caller and only talkback is heard.

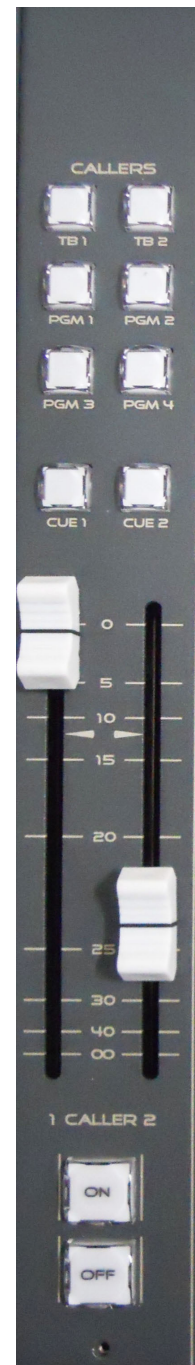

## Recording Calls

The *LIGHTNING* has two USB ports. USB 2 is designed to connect to a PC running VoxPro, Audition, or other recording app. The Monitor panel has switches for selecting the audio that goes to the computer. Turning on switch 3 for USB 2 will send the audio from the Callers to the left channel (switch 1 must be off). Turning on switch 4 for USB 2 will send a mono sum of the left and right channels of PGM 4 (switch 2 must be off).

For example, if you want to record a conversation with Caller 1, make sure that the Caller 2 fader is set to full off ( $\infty$ ) then adjust the Caller 1 fader for a good level on the call recording app. Assign the Callers to any bus other than PGM 4 (for this example, we will use PGM 3). Assign your recording mic channel to the PGM 4 bus, turn that channel on and adjust the channel fader for a good record level. You will also need to assign the mic channel to the same channel to which the callers are assigned (PGM 3 in this example) so that the callers can hear the mic. The caller will hear a mix-minus of the bus to which it is assigned (PGM 3). The callers will be recorded on the left channel of the computer, and PGM 4 will be recorded on the right channel.

**NOTE:** The Caller Out 1 and 2 trim pot settings do not affect the Telco Record output level.

**TIP:** To hear the caller, set Monitor dipswitch 1 - 2 to on to feed Cue into the console headphones or turn off dipswitch 1-4 so stop the cue speaker from muting while a mic is live.

## Control Room

This is the console operator's monitor that allows the operator to listen to the console's four stereo Program outputs and two external stereo line level inputs. This section of the console includes the monitor level controls for the control room, headphone, and cue circuits.

In a typical radio application the console is located in the Control Room. Speakers in the Control Room allow the console operator to listen to the console bus outputs to be assured that the console is performing as desired. These speakers are fed by a stereo signal from the console's Control Room output. In addition to the Control Room output, the operator may also desire to listen to specific isolated faders via the cue system and the console's internal cue speaker, or may want to listen via headphones. Thus, the control room monitor consists of the above mentioned level controls, along with four program assign buttons, and an external input buttons.

In some instances the console operator may also be performing talent whose voice will be heard over the radio. The operator's microphone may thus provide a part of the signal that is going out over the air. If that signal is the one being monitored with the Control Room speakers, there is the potential for feedback. The amplified signal from the Control Room speakers is picked up by the microphone and amplified to a new, higher, level, which then is once again picked up by the microphone. The signal quickly



rises to an ear-splitting screech. To prevent this, the operator's microphone is normally set to MUTE the Control Room output to prevent the occurrence of feedback.

The master CUE circuit drives a meterbridge-mounted speaker, and can be programmed to interrupt control room feed to the control monitor speakers. It also automatically interrupts the headphone feed.

## Source Select

The bank of source select switches selects the audio signal sent to the speakers and the headphones. This bank includes dedicated switches for selecting program or external source. Simply press the desired switch (PGM 1 - PGM4, EXT 1, or EXT 2) to listen to that output bus or external source signal. The button will be lit when the monitor is assigned to its respective bus. Adjust the volume of the headphones and speakers with the respective fader.

## EXT Switch

Pressing the EXT switch allows the operator to pick up the external input (useful for such items as tape recorders or air returns) to listen.

## SPLIT CUE

Activating the SPLIT CUE switch allows a summed (L+R) version of the regular program to be sent to the right side of the headphone output, while CUE audio is sent to the left side.

If CUE is allowed to interrupt the headphones (see the discussion of the CUE level Control below) and the SPLIT CUE button is lit, then the normal headphone feed bus will be mono summed to the left headphone and the CUE bus will be mono summed to the right headphone anytime a channel is put into CUE.

## CONTROL ROOM Fader

The CONTROL ROOM fader determines the overall loudness of the signal being monitored as it appears in the Control Room speakers.

**NOTE:** If the Control Room is muted and you move the fader all the way up, then remove the condition that has the Control Room muted, the sound in the Control Room speakers will suddenly be **VERY LOUD!**

## HEADPHONE Fader

The HEADPHONE fader determines the overall loudness of the headphone output signal, which monitors the same source as the Control Room speakers.

The headphone output signal appears at the headphone jack, located on the right side of the console. The jack is provided as a place to plug in user-supplied **stereo** headphones having an impedance of **60 Ohms or higher**.



## Bluetooth

Bluetooth module is located in the console's meterbridge. The **BLUETOOTH PAIR** button on the Master panel is a toggle action function. When the button is lit, the blue backlight LED's on the meterbridge below the timer display are also lit to indicate the BT module is powered up.

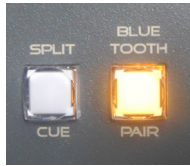

Once powered up the BT module is in pairing mode, and the blue and red LEDs on the BT module will be lit. Those LEDs are visible through cutout (shown on the right) in the meterbridge when meterbridge is open.

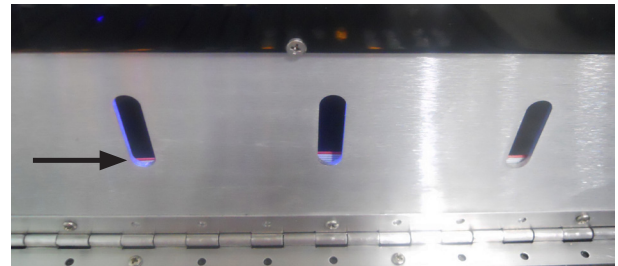

When in pairing mode, a scan of Bluetooth devices from a phone or other Bluetooth enabled device should show the device named **Lightning#** where # is a unique number assigned at the factory so that multiple consoles can be distinguished from each other. When pairing is complete, audio from the phone or other device will be present at the BT OUT connector. This audio can then be fed to any console input by connecting a patch cable from BT OUT to the input.

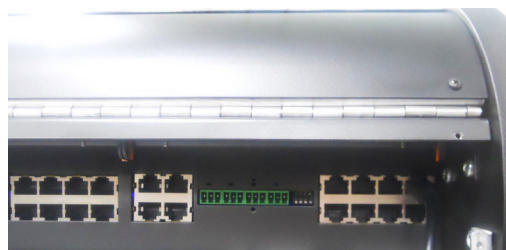

BT OUT  INPUT

When the **BLUETOOTH PAIR** button on the Master panel toggles off, the button's LED goes out immediately. After the 20 seconds or so the blue LEDs on the meterbridge will go out to indicate that BT module is powered down.

If the power is simply turned off to the console while BT is active, then the normal clearing operation doesn't take place. In that case, the BT module, once activated, will pair with any active device in its table.

Android phones seem to work well with this scenario. Not so much so for iPhones. Androids keep the **LIGHTNING** entry in their table and once the BT module is repowered and in pairing mode, a tap on Android prompts to re-pair and then all is good. However, the iPhone also keeps **LIGHTNING** in its table, but won't allow re-pairing until console is removed from the iPhone table manually and then re-scanned.

## Studio Control

In addition to the Control Room, there may be a Studio in which one or more performers will be assembled, usually with microphones so that their voices can become part of the mix. Speakers may be provided in the Studio to allow the talent to listen to the control surface bus outputs at times that they are not actually on air. These speakers are fed from the control surface's stereo Studio output.

The studio monitor section consists of STUDIO and CUE level controls, a TB (talkback) button, and six monitor source select buttons (PGM 1 - PGM4, EXT 1 and EXT 2).

### Source Select

The Studio monitor output has its own bank of source select switches which select the audio signal sent to the studio speakers. This bank includes dedicated switches for selecting program or external source. Simply press the desired switch (PGM 1 - PGM4, EXT 1, or EXT 2) to listen to that output bus or external source signal. The button will be lit when the monitor is assigned to its respective bus.

### CUE Level Control

The CUE level control determines the overall loudness of the cue signal as it appears in the console's cue speaker located behind the grill in the meterbridge.

Like the Control Room speakers, the cue speaker also has the potential for feedback. To avoid this situation, operator mics that mute the Control Room will also mute the cue speaker.

**NOTE:** If cue is muted and you turn the level control all the way up, then remove the condition that has the cue muted, the sound in the cue speaker will suddenly be VERY LOUD!

### TB (Talkback) Button

The TB button lets the operator's microphone signal interrupt the normal feed to the studio speakers, allowing the operator to talk to the performers in the Studio.

When the talkback switch is pressed (it is momentary action), any inputs assigned to the talkback bus (see the "Console Programming Options" section) will interrupt the regular monitor signal being sent to the studio output.

If the Studio Dim dipswitch (described below in the Console Programming Options section) is set to the ON position, the normal studio feed is not completely removed, but is dimmed by 20dB.

### STUDIO Level Control

The STUDIO level control determines the overall loudness of the signal being monitored as it appears in the Studio speakers.





## TIMER Buttons

The console timer is provided with an AUTO-RESTART function so that input modules can automatically reset the timer display (located on the meter-bridge) to zero and start a new count, allowing the announcer to easily track his own pace. The AUTO START button must be lit to enable this function.

The START/STOP function halts the timer, holds the last count, and then restarts and accumulates the count when depressed again—perfect for compiling tapes of desired duration. The START/STOP button is lit while the timer is counting.

**RESET** – Return to zero (if the timer is stopped it will hold at zero; if it is running it will reset to zero and immediately begin counting up).

**HOLD** – When held down freezes the timer display (the counter keeps on going); when released the display catches up to the current count.

## Meters

The METERS section consists of three VU meter pairs on the console's meterbridge and a METERS select button located on the Master Panel.



## VU Meter Pairs

VU meter pairs (PROGRAM 1, PROGRAM 2 and SWITCHED) are stereo LED bargraph type meters.

The level of the signal being metered is indicated by the number of display elements that are lighted. The more elements lighted, the stronger is the signal being displayed. The right four LEDs in each bargraph are red to indicate when the signal level is approaching a clipping (distorted) level. The next four LEDs are yellow, indicating a normal level range, and the remaining LEDs are green. The top member of the pair indicates the level of the signal's left channel, while the bottom member of the pair indicates the level of the signal's right channel.

The left VU meter pair shows the level of the PGM 1 output, the middle pair shows the PGM 2 output, and the right VU meter pair (SWITCHED) shows the level of the signal that is selected for it (PGM 3, PGM 4, EXT 1 or EXT 2).

## METER Select Button

The METER button selects the source for the switched meter pair, as indicated above.

## On Air LED

The ON AIR LED, located above the Program 1 meters, lights up when any of the input channel is programmed by dipswitch to have the TALLY dipswitch activated, and is also ON.

## Console Programming Options

All programming, except the Mic Preamp card, is made via PCB-mounted dipswitches located underneath the hinged meterbridge.

When a dipswitch position is up it is ON, looking from the operator.

## Input Panel

### Talkback

Typically, one of the console's input modules will be used for the control room console operator's microphone. When the console operator presses a TB switch on the console's Master module, the talkback bus (which is carrying his microphone pre-fader, pre-on/off signal) will interrupt the regular monitor signal being fed to the studio and talent will hear his voice through the studio monitor speakers.

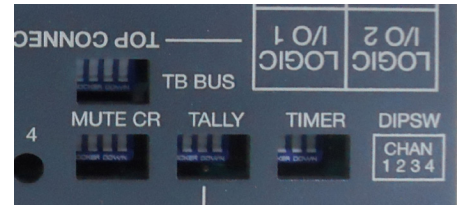

To accommodate those situations where more than one operator microphone is used, any number of input modules may be assigned to feed the talkback bus.

TB BUS dipswitch positions 1 - 4 allow the module's audio to feed the talkback bus.

### Mute CR

Input channels can be programmed to mute the control room speakers when the channel is ON. Positions 1 through 4 of the MUTE CR dipswitch, when activated, automatically mute the console's control room and cue speakers when the corresponding channels 1 through 4 are turned ON. This is done to prevent feedback from the CR announcer's mic. At the same time the ON AIR LED in the meterbridge will light up.

### On Air Tally

For controlling the "on-air" tally function, a relay is provided. Input channels can be programmed via TALLY dipswitch positions 1 - 4.

The relay connections are available at the TALLY RJ-45 connector mounted on the Master panel. Connect the on-air light to the external user-provided relay. Do not bring on-air light AC connections to any pin of any connector on the console.

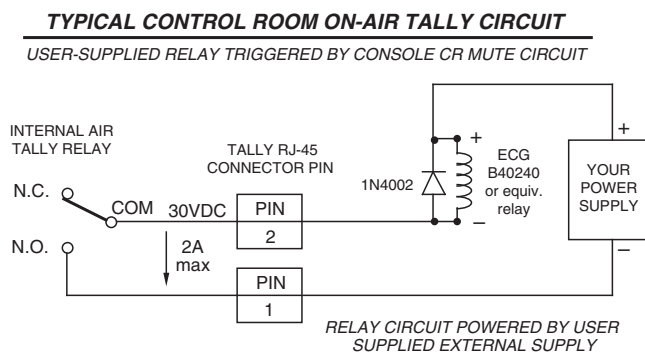

### Timer

The console's digital timer can be programmed to automatically reset to zero and begin counting up when the input channel's ON button is pressed.

Turning on TIMER dipswitch positions 1 - 4 activate timer restart for channels 1 - 4, respectively.

## Mic Preamp Card

### Mic Selection

Dipswitch SW2 positions 1 - 4 when ON will select the mic source for the input channels 1 - 4 (source A) respectively. To access these switches, power off the console by disconnecting the AC cord from the outlet or SPS-202, then remove the four mounting screws from the Input panel so that the panel can be lifted from the console frame. The switches are located on the underside of the panel. Replace the panel by carefully setting the panel in place, being sure that the rear connectors are properly aligned with the access holes in the rear of the frame, then replacing the four mounting screws. Reapply power to the console by reconnecting the AC cord.

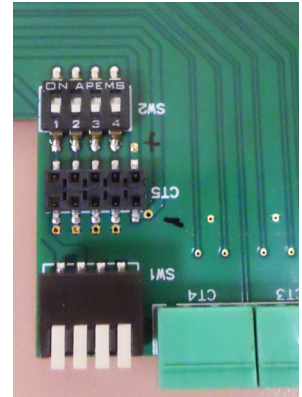

### Phantom Power

Dipswitch SW1 positions 1-4 enable phantom power for microphone inputs 1 - 4 respectively. This dipswitch can be accessed from the rear of the console and is located next to the microphone audio input connectors. Having a switch in the up position turns phantom ON.

## Master Panel

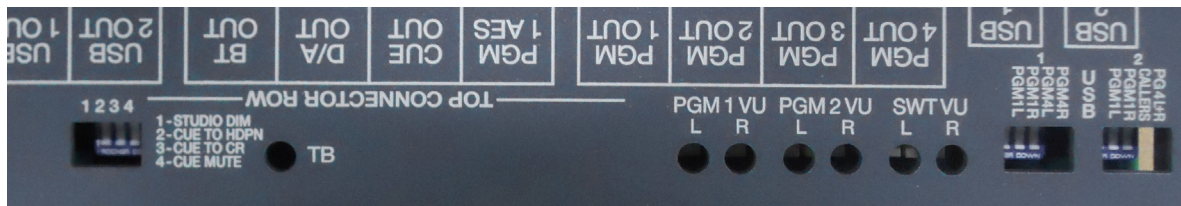

### Studio Dim

Normally, when the TB button is pressed, the operator's microphone signal interrupts the normal feed to the studio speakers, allowing the operator to talk to the performers in the studio. Turning on the STUDIO DIM switch causes the normal feed to the studio to drop 20 dB when the TB button is pressed, allowing the operator to talk over the normal audio feed instead of completely interrupting it.

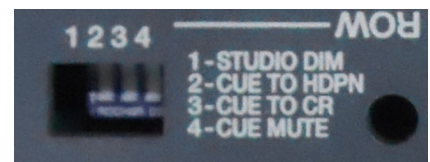

### Cue To Headphone

Normally you would want the CUE speaker muted when you have a mic channel turned on so the mic doesn't pick up anything in CUE at the time. The CUE TO HDPN dipswitch, when activated, allows the operator to hear CUE in his headphones when his mic is turned on.

### Cue To CR

The dipswitch CUE TO CR, when activated, sends cue to the control room.

### Cue Mute

The audio from both the control room speakers and the console's built-in meterbridge speaker can easily be picked up by the console operator's microphone. This is a potential

source of feedback. For this reason the console provides muting to the control room output and, optionally, the built-in cue speaker, whenever a mic programmed for control room mute is turned ON.

Turning on the CUE MUTE dipswitch will mute cue whenever the CR output is muted by an input channelset to activate the CR mute.

## USB Source Selection

Two dipswitches are used to determine sources to feed the USB links. Positions 1 and 2 should be on to feed USB 1 and USB 2 with PGM 1, while positions 3 and 4 should be on to feed USB1 with PGM 4 and to feed USB2 with sum of callers and sum of L+R PGM4, respectively.

If PGM 1 is to be used, the PGM4 positions should be off, and if PGM 4 is to be used, the PGM1 positions should be off. **DO NOT** activate both PGM 1 and PGM 4 simultaneously!

### Dipswitch USB 1:

- pos.1 selects PGM 1 LT
- pos.2 selects PGM 1 RT
- pos.3 selects PGM4LT
- pos.4 selects PGM4RT.

### Dipswitch USB 2:

- pos.1 selects PGM 1 LT
- pos.2 selects PGM 1 RT
- pos.3 selects SUM OF CALLERS
- pos.4 selects SUM OF PGM4LT & PGM4RT.

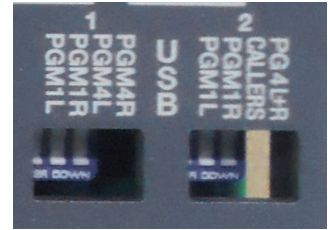

# Appendices

---

## Appendix 1

Installing the Additional Mic Preamp Card .....A-3

---

## Appendix 2

Replacement Parts List.....A-5

# Appendix 1

## Contents

Installing the Additional Mic Preamp Card .....A-3

## Installing the Additional Mic Preamp Card

The additional Mic Preamp card comes complete with mounting hardware.

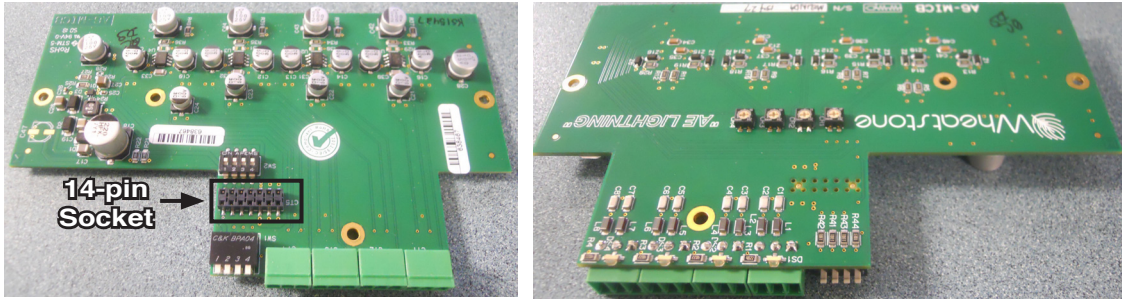

Perform the following steps to install the Mic Preamp card:

- Turn off the power to the console.
- Remove the screws that hold the Input panel down, and carefully remove the panel from the frame. Caution: Ribbon cable will be plugged into the panel.
- Place the Input panel face side down; remove the three screws from the top of the PCB.
- Screw down three (440x3/16"Hex x 1/4"long) standoffs into #1, #2 and #3 positions. Note that fourth standoff (pos.#4) comes assembled on the card.

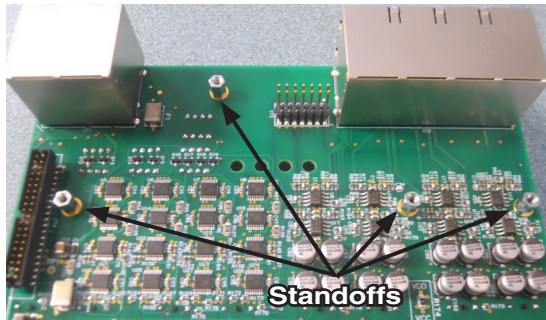
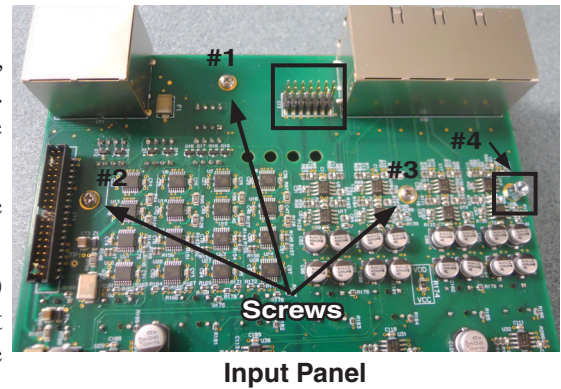

- Plug-in the Mic card's 14-pin socket into the Input panel's 14-pin header and screw down three previously removed screws, and one supplied screw (440x3/16 Phillips panhead) to secure the Mic Preamp card.
- Remove the metal plate from the rear of console to get access to Mic's connectors.

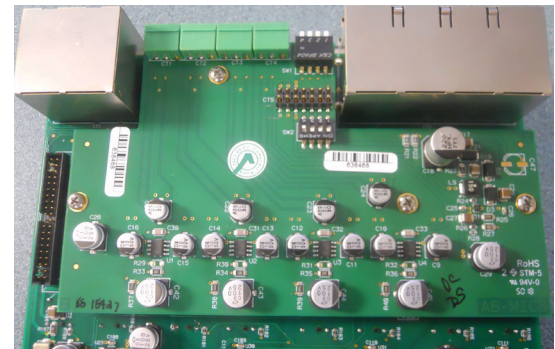

Input Panel with Mic Preamp Card Installed

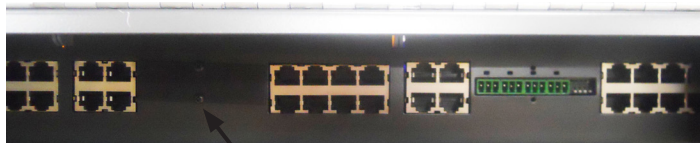

Metal Plate

- Set appropriate dipswitches to enable Mic Preamp to Input A. See "Console Programming Options" on page 2-15 for details.
- Re-install the removed Input panel.

This completes the Mic Preamp card installation procedure.

## Appendix 2

### Contents

Replacement Parts List.....	A-5
-----------------------------	-----

---

For the most part there are no user-replaceable parts in the *LIGHTNING* console. Exceptions are those controls and components that in the course of normal use may need maintenance (i.e., faders, pots, ON/OFF switches, etc.). A complete list of available components is shown on the next page. Contact Audioarts Engineering technical support for further information.

**Audioarts Engineering** (600 Industrial Drive, New Bern, North Carolina, USA 28562) may be reached by phone at 252-638-7000, fax 252-637-1285, electronic mail “techsupport@wheatstone.com”.



<b>REPLACEMENT PARTS - LIGHTNING CONSOLE</b>		
<b>COMPONENT</b>	<b>DESCRIPTION</b>	<b>WS P/N</b>
AEL-IP MODULE	COMPLETE INPUT MODULE	012300
AEL-MSTR MODULE	COMPLETE MASTER MODULE	012301
AEL-IP LOADED CARD	INPUT PANEL LOADED CARD ASSEMBLY	012322
AEL-MSTR LOADED CARD	MASTER PANEL LOADED CARD ASSEMBLY	012324
AEL-MIC LOADED CARD	MICROPHONE LOADED CARD ASSEMBLY	012326
AEL-VU LOADED CARD	VU METERS LOADED CARD ASSEMBLY	012328
AEL-PWI LOADED CARD	POWER INTERFACE LOADED CARD ASSEMBLY	012320
AEL-BT LOADED CARD	BLUETOOTH LOADED CARD ASSEMBLY	012329
AEL BLANK FACEPLATE	BLANK FACEPLATE 6.5"	012356
FADER	100MM 10K DUAL AUDIO COND PLASTIC FADER	540073
POT	"STUDIO" 10K DUAL AUDIO POT w/1/4" SHAFT	500029
POT	"CUE" 10K SINGLE LINEAR POT w/30MM SHAFT	520136
FADER KNOB	WHITE FADER KNOB WITH BLACK LINE	520051
POT KNOB	21MM BLACK KNOB FOR "STUDIO" POT	520124
POT KNOB	15MM BLACK PUSH-ON KNOB FOR "CUE" POT	520125
POT CAP	11MM BLACK CAP w/WHITE LINE KNOB FOR "CUE" POT	530037
POT CAP	21MM BLACK CAP w/WHITE LINE KNOB FOR "STUDIO" POT	530319
SWITCH	LAKEVIEW SWITCH w/SMALL CLEAR CAP & YELLOW LED	510315
SWITCH	LAKEVIEW SWITCH w/LARGE CLEAR CAP & WHITE LED	510316
SWITCH	LAKEVIEW SWITCH w/LARGE CLEAR CAP & BLUE LED	510317
CONNECTOR	4x2 STACKED R/A SHIELDED RJ-45 CONNECTOR	260086
CONNECTOR	2x2 STACKED R/A SHIELDED RJ-45 CONNECTOR	260089
CONNECTOR	USB-B R/A SHIELDED RJ-45	260090
RTS JACK	HEADPHONE JACK	260005
HEADER	3 PIN HEADER	250062
HEADER	6 PIN HEADER	250065
HEADER	6 PIN R/A HEADER	250163
HEADER	3-CIRCUIT R/A HEADER W/MOUNTING TABS	270094
POWER SUPPLY	SPS-130 RACKMOUNT POWER SUPPLY +/-16V 130W	007570
POWER SUPPLY CABLE	CABLE TO CONNECT CONSOLE AND POWER SUPPLY	007575
POWER CONNECTOR	POWER CONNECTOR W/PC TERMINALS, AC	230071
POWER CORD	7 1/2" BLACK POWER CORD	150017
SPEAKER	CONSOLE METERBRIDGE SPEAKER	960016
MANUAL	TECHNICAL MANUAL FOR LIGHTNING CONSOLE	012399