

# 250 Series Shotgun Microphones

# AZDEN'S TRIPLE THREAT



Azden's  
250  
series

shotgun microphones offer video and sound professionals excellent audio quality and dependability at an affordable price, with a variety of feature sets for various production circumstances. All three models in this series are handcrafted in Japan and offer a 10 year warranty (with online registration). Additionally, the 250 series microphones feature the same high-sensitivity condenser microphone element and same length interference tube for consistent sound quality and side noise rejection performance across all models.

**AZDEN**® *Handcrafted in Japan*

The 250 series microphones have become notable in the industry for their natural, professional sound. While other manufactures hype-up the bass response on their microphones, making the audio sound muddy, or over-accentuate high mids, making dialogue tracks sound harsh, you can expect the SGM-250, SGM-250P or SGM-250CX microphone to accurately record the sound of your scene.

## **SGM-250** Professional Dual Powered Shotgun Microphone

The SGM-250 is the flagship model of the series, offering dual power options of either a single AA battery or by 48 V phantom power. Users can expect practically identical performance when using either powering option. Two easily accessible switches are located on the microphone: a two-stage power switch allows users to change powering options, while a convenient LED light indicates when battery power is getting low, and a low-cut filter switch effectively reduces low-frequency noise with a smooth roll-off of 3 dB per octave below 160 Hz. Measuring at a length of 250 mm (or just under 10"), the SGM-250 is a great option for boom-pole mounting.

## **SGM-250P** Professional Shotgun Microphone

The SGM-250P offers the same great features and performance as the SGM-250 microphone but without the option of running off battery power, therefore getting power exclusively by 48 V phantom. This has a number of advantages to users who do not require a self-powered microphone, namely a price savings over the dual powered option, and because there is no need for a battery compartment, the overall microphone length is shorter at 200 mm (or just under 8"). Still available is the low-cut filter switch, which provides the same smooth, low-frequency roll-off of 3 dB per octave below 160 Hz. The SGM-250P is another great option for boom-pole mounting.

## **SGM-250CX** Professional Compact Cine Mic

The SGM-250CX is a short length, phantom powered shotgun microphone that is ideal for mounting on compact digital cinema cameras, as well as DSLR and mirrorless cameras equipped with XLR adapters. Measuring at a mere 6 inches in length, the SGM-250CX can easily stay out of the way. Integrated in the microphone's design is a hardwired, 13-inch XLR cable for convenient connection to camera microphone inputs. The CX's compact size gives it the unique advantages of being the most affordable model in the line and suitable for both on-camera and boom-pole mounting.

# 250 Series Shotgun Microphones

SGM-250 / SGM-250P / SGM-250CX

## Series Highlights

- Newly developed electret condenser microphone element delivers the best sensitivity and lowest noise in its class
- Powered by standard 48 V DC phantom power
- Custom designed acoustic tube with high precision phase canceling slots produces a flat frequency response with excellent directionality and wide dynamic range
- Brass/aluminum alloy case for improved durability and resistance to ambient RF
- Gold plated, 3-pin XLR output connector
- 10 year warranty with online registration

## SGM-250

- Dual power option with AA battery or phantom power
- LED battery indicator light and low-cut filter switch

## SGM-250P

- Low-cut filter switch

## SGM-250CX

- Compact design works great with cinema cameras and for mounting on top of mirrorless cameras
- Attached cable with 13" length
- Includes durable, innovative SMH-X shock mount



## POLAR PATTERN

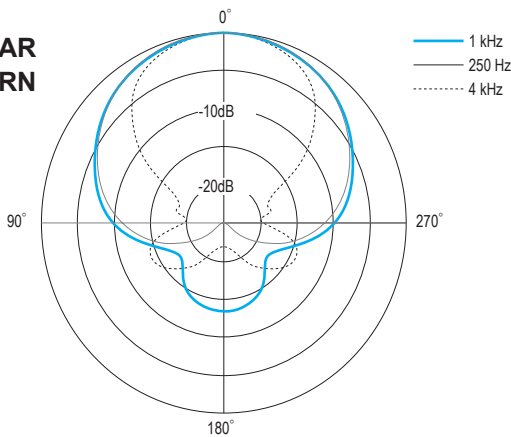

## FREQUENCY RESPONSE

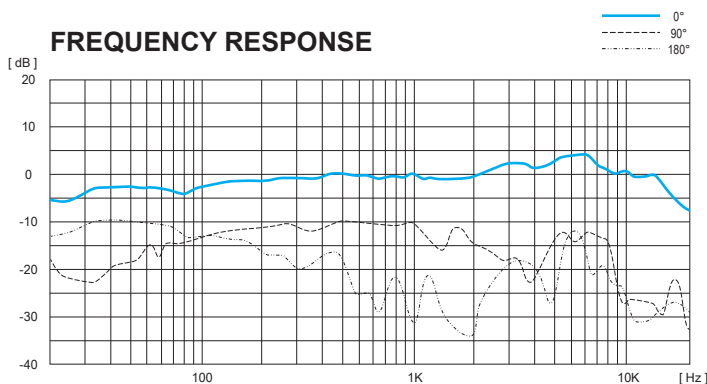

## SPECIFICATIONS

	SGM-250	SGM-250P	SGM-250CX
Freq. Response:	20 Hz – 20 kHz	20 Hz – 20 kHz	20 Hz – 20 kHz
Polar Pattern:	Super-cardioid	Super-cardioid	Super-cardioid
Sensitivity: at 1 kHz (0 dB = 1 V/Pa)	-38 dB	-38 dB	-33 dB
Dynamic Range:	112 dB	112 dB	115 dB
Impedance: (at 1 kHz)	120 Ω	120 Ω	100 Ω
Max Input SPL: (1 kHz at 1% T.H.D.)	130 dB w/ P48 127 dB w/ battery	130 dB	130 dB
S/N Ratio: (1 kHz at 1 Pa)	76 dB	76 dB	77 dB
Power Requirement:	DC 11-50 V or AA battery	DC 11-50 V	DC 11-50 V
Output:	3-pin XLR	3-pin XLR	3-pin XLR
Dimensions:	250 x φ21 mm (9.84" x φ0.83")	200 x φ21 mm (7.87" x φ0.83")	153 x φ21 mm (6.02" x φ0.83")
Cable:	N/A	N/A	φ5 mm x 330 mm
Weight:	160 g (5.7 oz)	90 g (3.2 oz)	85 g (3.0 oz)
Accessories:	SMH-3 shock mount foam windscreen carrying pouch	SMH-3 shock mount foam windscreen carrying pouch	SMH-X shock mount foam windscreen carrying pouch rubber sheets

AZDEN CORPORATION

200 Valley Rd STE 101, Mt. Arlington, NJ 07856 • T: +1 973 810 3070 • F: +1 973 810 3076 • email: sales@azden.com

LEARN MORE ABOUT AZDEN PRODUCTS AT [www.azden.com](http://www.azden.com)