



Broadcast Devices, Inc.

***IOX-24 Expansion Panel for Use with BDI SWP-200 Motorized
Switch Controllers and SWP-300 Remote Control Systems***

Technical Reference Manual

Broadcast Devices, Inc.

Tel. (914) 737-5032

Fax. (914) 736-6916

World Wide Web: www.Broadcast-Devices.com

Rev A. 9/20

Table of Contents

I.	Introduction	3
II.	Installation and Setup	3
III.	Connector Diagrams	5
IV.	Connector Layout Diagram	6
V.	Warranty Information	7

I. Introduction

The IOX-24 Expansion Panel is designed to interface directly to all Generation II SWP-200/300 series controllers. It provides 24 channels of relay outputs and 24 channels of status inputs. In addition it provides 8 channels of analog inputs.

II. Installation and setup

Choose a suitable location in any standard EIA 19” rack enclosure within connection reach to the SWP series chassis.

Next connect the supplied interface cable to the SWP series rear panel connector J4 DSUB-25 IOX-24 I/O rear panel and connect the other end of this cable to the IOX-24 RS232 connector. Early edition models this will be a DSUB-9 connector. On later models it is an RJ45 connector. Once connected go to the SWP APP and select the Network/Connection Tab shown below.

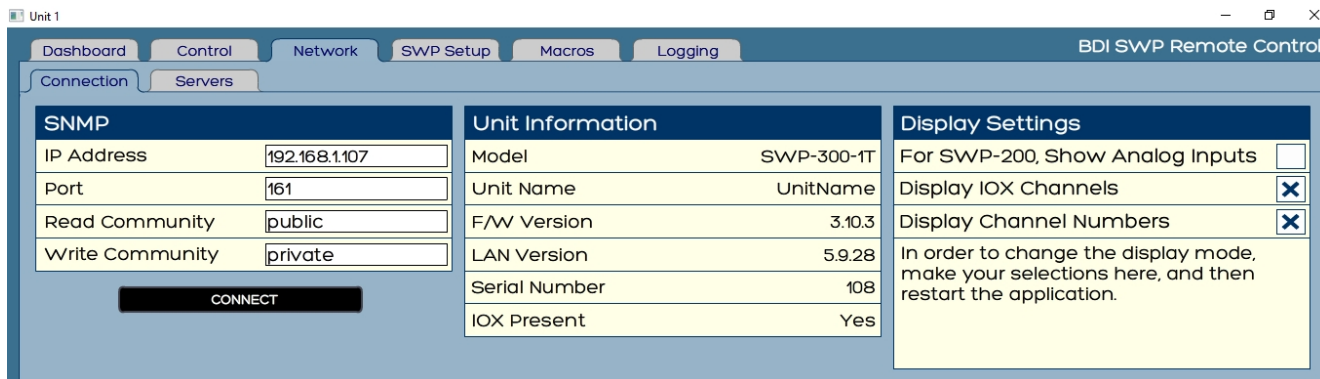

The screenshot shows the BDI SWP Remote Control application window. The title bar reads "Unit 1" and "BDI SWP Remote Control". The interface has a navigation bar with tabs: Dashboard, Control, Network, SWP Setup, Macros, and Logging. The "Network" tab is active, and the "Connection" sub-tab is selected. The main content area is divided into three panels:

- SNMP:** A table with four rows: IP Address (192.168.1.107), Port (161), Read Community (public), and Write Community (private). Below the table is a black "CONNECT" button.
- Unit Information:** A table with six rows: Model (SWP-300-1T), Unit Name (UnitName), F/W Version (3.10.3), LAN Version (5.9.28), Serial Number (108), and IOX Present (Yes).
- Display Settings:** A panel with three settings: "For SWP-200, Show Analog Inputs" (checkbox), "Display IOX Channels" (checkbox with an 'x'), and "Display Channel Numbers" (checkbox with an 'x'). Below these is a text box: "In order to change the display mode, make your selections here, and then restart the application."

In Display Settings select the Display IOX Channels and Display Channel numbers if desired. Setting Display IOX Channels will allow the SWP app to display all 24 channels of Relay Outs, Status Inputs and Analog Inputs on the Dashboard tab and provides access to the Control/IOX Relays, IOX GPIO and IOX Analog Input tabs and the IOX Setup tab. The Display Channel Numbers selection provides channel numbering of the parameters on the Dashboard tab. Mousing over any of these indicators will reveal the name of that indicator regardless. Once these settings have been made close the app and restart it for the settings to take effect.

III. Connections

12 position removable connectors are provided for all external connections to the unit. See the accompanying diagrams for connector connection information

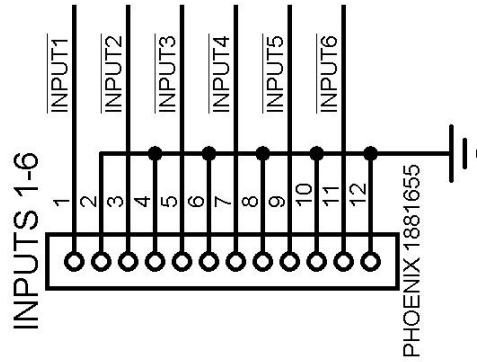

Status Inputs 1-6 shown above – use same connection scheme for Inputs 7-12, 13-18 and 19-24. Use the overall diagram for connector placement.

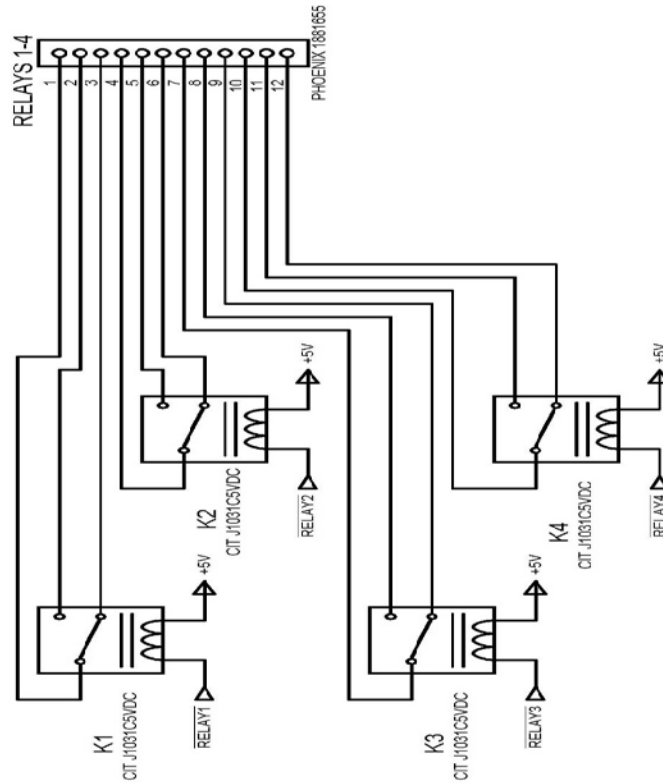

Relay Outputs 1-4 shown above – use the same connection scheme for Relay outs 5-8, 9-12, 13-16, 17-20, 21-24 Use overall diagram for connector placement.

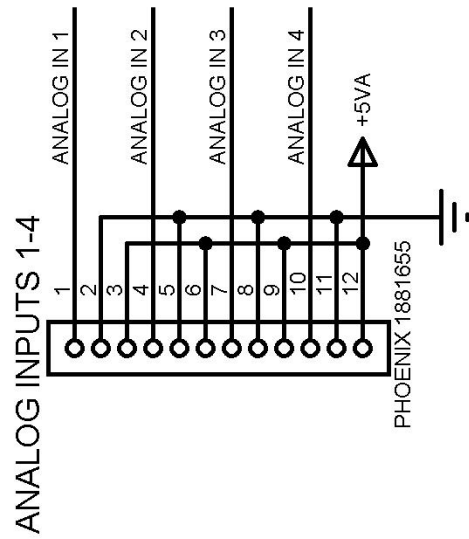

Analog Inputs 1-4 shown. Use the same connection scheme for Analog inputs 5-8. Use overall diagram for connector placement.

IV. IOX-24 Connector Layout

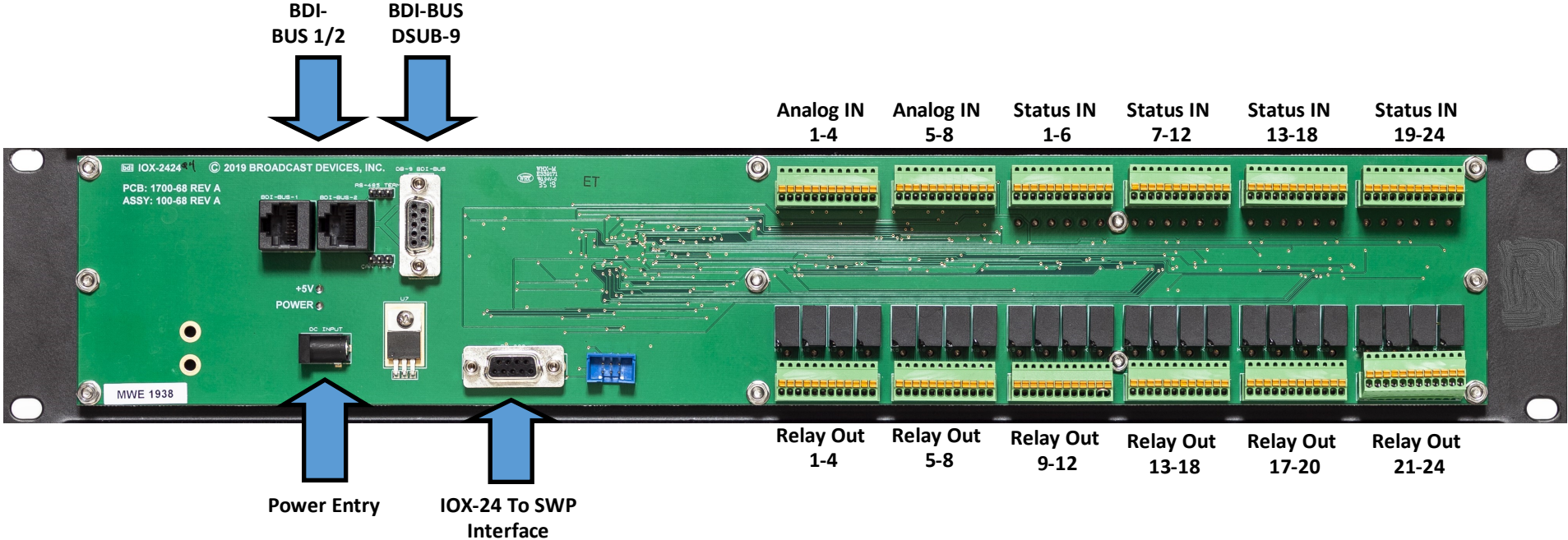

BDI—IOX-24 Expansion Panel Connector Layout

V. Warranty

Broadcast Devices, Inc. products are warranted against failure due to faulty materials or workmanship for a period of one year from the date of shipment from Broadcast Devices, Inc. dock. The warranty covers repair or replacement of defective parts at the factory, provided the unit has been returned prepaid by the user. All shipments to the factory shall have affixed to the outside of the container a return authorization number obtained from the factory. The above warranty is void if the unit has been modified by the user outside of any recommendations from the factory or if the unit has been abused or operated outside of its electrical or environmental specifications. If customer conducted field tests suggest that the unit may be faulty, whether or not the unit is in warranty, a full report of the difficulty should be sent to Broadcast Devices, Inc. factory. The factory may suggest further tests or authorize return for factory evaluation. Please email: customer.service@broadcast-devices.com

Units sent to the factory should be well packed and shipped to Broadcast Devices, Inc. – Check www.broadcast-devices.com for current shipping address. Remember to affix the R.A. number to the outside of the carton. Any packages received without such R.A. number will be refused. Note: freight collect shipments will also be refused. When the unit has been received, inspected and tested, the customer will receive a report of the findings along with a quotation for recommended repairs, which are found falling outside of the standard warranty. Units returned for in-warranty repairs, which are found not to be defective will be subject to an evaluation and handling charge. In-warranty units will be repaired at no charge and returned via prepaid freight.

Out-of-warranty units needing repair require a purchase order and will be invoiced for parts, labor, and shipping charges.

When ordering replacement part, always specify A) Part Description, and Quantity; B) Date of Purchase, Where Purchased; C) Any Special Shipping Instructions. Always specify a street address, as shipping companies cannot deliver to a postal box.

Broadcast Devices, Inc. is not responsible for any other manufacturer's warranty on original equipment. Nor are we responsible for any failure, damage, or loss of property that may occur due to the installation or operation of our equipment outside of recommended specifications.

Email: Customer.service@broadcast-devices.com

Broadcast Devices, Inc. reserves the right to change materials, specifications, and features from time to time. www.broadcast-devices.com

Tel. (914) 737-5032 Facsimile: (914) 736-6916