

# PCC-300 Three RF Switch Controller

## SNMP Controller for Transmitter Cabinet Power Combiners

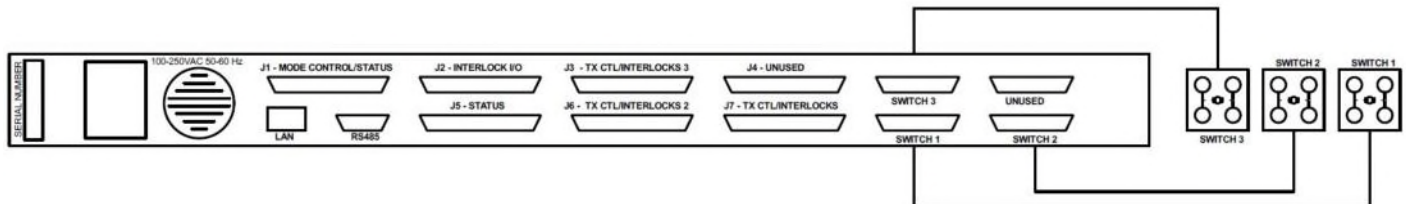

PCC-300 RF Switch Controller, front panel



PCC-300 RF Switch Controller, rear panel

## Features

- A modern approach to RF switch control in a compact 1 RU chassis form factor
- Management/Control/Status of up to three (3) - RF switches with interlock control
- Compatible with all major manufacturers' RF transfer switches
- Optional factory-fabricated RF Switch Control Cables available for most manufacturers' RF switches
- Front Panel Control/Status of Switch Positions for Each Mode: Xmtr A + B To Air, Xmtr A to Air and Xmtr B to Test Load, Xmtr B to Air and Xmtr A to Test Load, Xmtr A + B to Test Load
- Built-in LAN Port Provides Remote Control Via Supplied BDI Windows GUI Software, and as an SNMPv2 Agent
- Local Control/Status Connectors Provided for Interface to Legacy Remote Controls or Local Control/Status Panel
- Inputs available for "RF Safe" Switch Operations- Protects Against Switch Damage
- Operating mode control available via GPIO, with status available via SNMP
- Dual power supplies with separate power cords are optionally available.

## Product Description

The PCC-300 controller is designed for high-power transmitters that employ hybrid power combiners to combine two final power amplifier cabinets, achieving higher power output. These systems employ motorized coaxial or waveguide RF switches, or switchless combiners, to bypass the hybrid power combiner and put one of the two transmitter cabinets on-air by connecting directly to the antenna, while switching the other cabinet off-line for maintenance or repair, thereby minimizing off-air time. The unit supports four (4) operating modes: Combined Transmitter Cabinets A + B to Air, Transmitter Cabinet A to Air/Transmitter Cabinet B to Test Load, Transmitter Cabinet B to Air/Transmitter Cabinet A to Test Load, and Combined Transmitter Cabinets A + B to Test Load

The PCC-300 provides connections for up to three (3) motorized RF switches. All interlocks are managed by the controller to interface with any desired interlock system. The PDC-300 includes web access and SNMP v2 support. SNMPv2 support is provided via an MIB for use with remote control systems and third-party software. Broadcast Devices also provides Microsoft Windows Application software for remote control and system setup. The free software and the SNMP MIB file are available for download from the PDC-300 product page on our website. Of course, the PDC-300 has local GPIO control/status connections as well for local control/ status panels or a legacy remote-control interface.

# PCC-300 Three RF Switch Controller

## PCC-300 Windows App Graphical User Interface Control and Status Screen

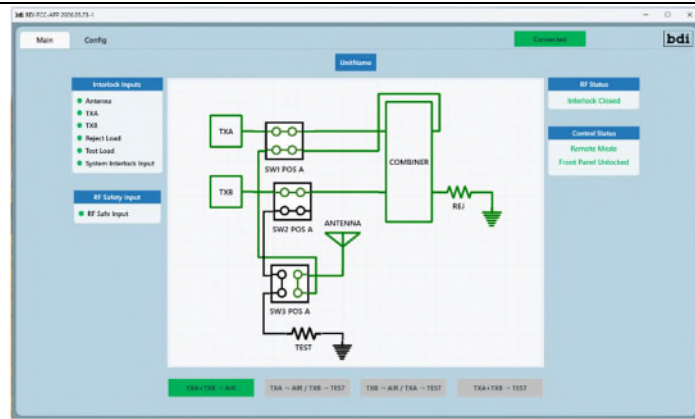

Transmitters A + B to Air

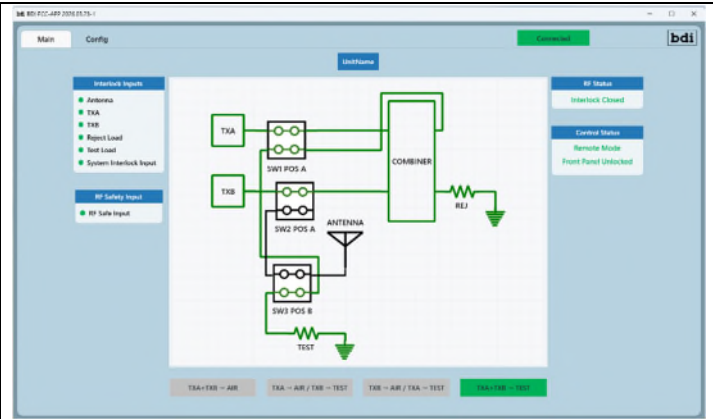

Transmitter A and Transmitter B to Test Load

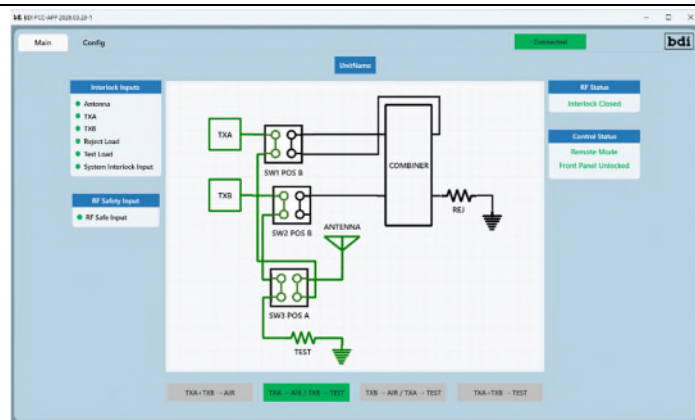

Transmitter A to Air and Transmitter B to Test Load

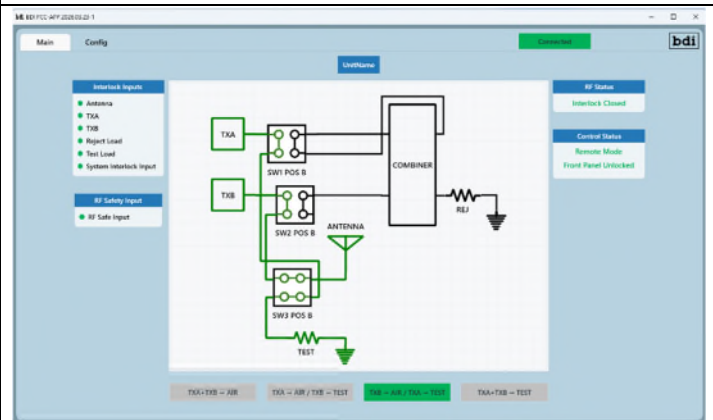

Transmitter B to Air and Transmitter A to Test Load

### Technical Specifications

### PCC-300

Switch Control Voltage:	12 or 24 VDC-Selectable for Each Switch
Number of Switches Supported:	Three (3)
Switch Manufacturers supported but not limited to:	Delta, Delta Meccanica, Dielectric 50/60K, DowKey, ERI, Kintronics, Mega/MCI, Myat, Spinner
Transmitter and Interlock Control:	Each Switch movement supports Interlock Open/Closure for safe switch operations with 12 available relays plus 12 relays for Full/Half Power command.
Transmitter Interface:	Form C dry contact relays
GPIO Remote Control interface:	Xmtr A + B To Air, Xmtr A to Air and Xmtr B to Test Load, Xmtr D to Air and Xmtr A to Test Load, Xmtr A + B to Test Load, and command/status
Connector Style:	DSUB25 Female for control/interlocks, DSUB15 Female for switch interface
Communications Interface:	Ethernet TCP/IP, SNMPv2 Agent (MIB supplied), and supplied BDI Windows Graphical User Interface
Switch Interface Connectors:	DSUB15F
RS232 Serial Connector:	DSUB25F
RS485 Serial Connector:	DSUB9F
Ethernet LAN Connector:	RJ45
Power Requirements:	100 to 240 VAC, 50/60 Hz, 0.5 amps

# PCC-300 Three RF Switch Controller

Technical Specifications		PCC-300
Operating Ambient Temperature:	32 to 122 degrees, F (0 to 50 degrees, C)	
Humidity:	95%, Non-condensing	
Mechanical Dimensions:	19 in W x 10 in D x 1.75 in H (483 mm W x 254 mm D x 44 mm H) Standard One EIA Rack Unit Enclosure	
Shipping Dimensions:	22 in W x 14 in D x 7 in H (559 mm W x 356 mm D x 178 mm H)	
Shipping Weight:	15 lbs. (7 kg)	

Part Number	Description
PCC-300	Three Switch Mode Controller for Combined Transmitter System Applications -SNMP Enabled. 3 switch motorized switch controller for use in typical dual cabinet transmitter systems being combined by a hybrid combiner. Provides control and status of 3 switches configured to provide operational modes of: Xmtr A + B To Air, Xmtr A to Air and Xmtr B to Test Load, Xmtr D to Air and Xmtr A to Test Load, and Xmtr A + B to Test Load.
PCC-300-R	Three Switch Mode Controller for Combined Transmitter System Applications -SNMP Enabled with Redundant Power Input. Same as PCC-300 but with redundant power input - requires the use of RPSC-PS redundant power supply available from BDI.
SWP Option #23	Auxiliary Interlock Relay Board for the PCC-300, PDC-300, SWP-200 Series and SWP-206 Series Chassis. An optional relay board provides eight (8) additional relay (NC/C/NO) interlock closures bringing the total to sixteen (16) relays.
RPSC-PS	Redundant Power Supply Chassis for Use with All R Suffix Switch Controllers above Includes 3-foot (1 Meter) Cabling. Single RU chassis with power supply connection to all R suffixed model number motorized switch controllers and includes the interface cable to the controller.

**PCC-300 Windows App Graphical User Interface Control and Status Screen Transmitters A + B to Air**