

EX1000 SERIES IR LASER PRO SDI+IP Dual Output PTZ CAMERA

USER MANUAL

Part One: Camera User Manual

VERSION: EXSN2-B-M-02202021



Contents

| | |
|--|-----------|
| IMPORTANT INFORMATION | 4 |
| OVERVIEW | 6 |
| WHAT'S IN THE BOX | 7 |
| CAMERA DIAGRAMS | 8 |
| SYSTEM CONNECTION DIAGRAM | 9 |
| INSTALLING YOUR CAMERA | 9 |
| CABLE REQUIREMENTS | 9 |
| POWER INPUT | 11 |
| POE POWER INJECTOR | 12 |
| CAMERA MOUNTING | 12 |
| IR LASER ILLUMINATOR | 16 |
| USE SDI VIDEO OUTPUT | 16 |
| STARTING THE CAMERA | 16 |
| CONNECT CAMERA TO MONITOR/SDI DEVICE | 16 |
| CONTROL THE CAMERA - SETUP CAMERA ID, BAUD RATE AND CONTROL PROTOCOL | 17 |
| NOTE: | 18 |
| ADJUSTING AND SETTING WITH MENUS | 19 |
| THE ON-SCREEN MENU CONFIGURATION | 19 |
| EXPOSURE MENU | 20 |
| WHITE BALANCE MENU | 21 |
| PICTURE MENU | 21 |
| LENS PARAMETERS MENU | 22 |
| SYSTEM SETUP MENU | 24 |
| TRUE DUAL OUTPUT VIDEO FORMAT SETTING | 25 |
| FUNCTION SETTING MENU | 26 |
| FIRMWARE UPGRADE | 29 |
| UPGRADING IP ENCODER FIRMWARE | 29 |
| UPGRADING MCU (MICRO CONTROL UNIT) FIRMWARE | 29 |
| USE IP VIDEO OUTPUT | 30 |
| SETTING CAMERA OVER THE LAN | 30 |
| ACCESSING YOUR CAMERA | 30 |
| MENU CONFIGURATION | 31 |
| DIMENSIONS | 35 |

Operating Instructions

Thank you for purchasing our product. If there are any questions, please contact the authorized dealer.

Before operating the unit, please read this manual thoroughly and retain it for future reference.

Copyright

Copyright 2015-2021 Bolin Technology all rights reserved. No part of this manual may be copied, reproduced, translated, or distributed in any form or by any means without prior consent in writing from our company.

Trademark Acknowledgement

 and other Bolin's trademarks and logos are the property of Bolin Technology Other trademarks, company names and product names contained in this manual are the property of their respective owners.

Trademarks and Registered Trademarks Acknowledgement

- Microsoft, Windows, ActiveX, and Internet Explorer are registered trademarks of Microsoft Corporation in the U.S. and/or other countries.
- HDMI, the HDMI logo and High-Definition Multimedia Interface are the trademarks or registered trademarks of HDMI Licensing, LLC in the United States and other countries.
- The Software may contain h.264/AVC video technology, the use of which requires the following notice from MPEG-LA, L.L.C.:

THIS SOFTWARE IS LICENSED UNDER THE AVC PATENT PORTFOLIO LICENSE FOR THE PERSONAL AND NON-COMMERCIAL USE OF A CONSUMER TO (I) ENCODE VIDEO IN COMPLIANCE WITH THE AVC STANDARD ("AVC VIDEO") AND/OR (II) DECODE AVC VIDEO THAT WAS ENCODED BY A CONSUMER ENGAGED IN A PERSONAL AND NON-COMMERCIAL ACTIVITY AND/OR WAS OBTAINED FROM A VIDEO PROVIDER LICENSED TO PROVIDE AVC VIDEO. NO LICENSE IS GRANTED OR SHALL BE IMPLIED FOR ANY OTHER USE. ADDITIONAL INFORMATION MAY BE OBTAINED FROM MPEG LA, L.L.C. SEE <http://www.mpegla.com>.

- HEVC/H.265 Covered by one or more claims of patents listed at patentlist.hevcadvance.com
- HDBaseT is a trademark of the HDBaseT Alliance.
- ONVIF trademarks and logos are to be used per the guidelines established in this and other ONVIF policies and documents including the ONVIF Rules of Membership and the ONVIF Logo Guidelines1.
- Other trademarks, company names and product names contained in this manual are the property of their respective owners.

IMPORTANT INFORMATION

Legal Notice

Attention:

To ensure account security, please change the password after your first login. You are recommended to set a strong password (no less than eight characters). Password login does not apply to some models that do not need password login.

The contents of this document are subject to change without prior notice. Updates will be added to the new version of this manual. We will readily improve or update the products or procedures described in the manual. Best effort has been made to verify the integrity and correctness of the contents in this document, but no statement, information, or recommendation in this manual shall constitute formal guarantee of any kind, expressed or implied. We shall not be held responsible for any technical or typographical errors in this manual. The product appearance shown in this manual is for reference only and may be different from the actual appearance of your device.



This manual is a guide for multiple product models and so it is not intended for any specific product.

In this manual, the illustrations of displayed interface, parameters displayed, drawings and value ranges may vary with models. Please see the actual product for details.

Due to uncertainties such as physical environment, discrepancy may exist between the actual values and reference values provided in this manual.

Use of this document and the subsequent results shall be entirely on the user's own responsibility.

Symbols

| Symbol | Description |
|---|---|
|  WARNING! | Contains important safety instructions and indicates situations that may cause bodily injury. |
|  CAUTION! | User must be careful and improper operations may cause damage or malfunction of product. |
|  NOTE! | Indicates useful or supplemental information about the use of product. |

Safety Information

WARNING!

Installation and removal of the unit and its accessories must be carried out by qualified personnel. You must read all of the Safety Instructions supplied with your equipment before installation and operation.

Warnings:

- If the product does not work properly, please contact your dealer. Never attempt to disassemble the camera yourself. (We will not assume any responsibility for problems caused by unauthorized repair or maintenance.)
- This installation should be made by a qualified service person and should conform to all the local codes.
- When shipping, the camera should be packed in its original packaging.
- Make sure the power supply voltage is correct before using the camera.
- Do not drop the camera or subject it to physical shock.
- Do not touch sensor modules with fingers. If cleaning is necessary, use a clean cloth with a bit of ethanol and wipe it gently. If the camera will not be used for an extended period of time, put on the lens cap to protect the sensor from dirt.
- Do not aim the camera lens at the strong light such as sun or incandescent lamp. The strong light can cause fatal damage to the camera.
- The sensor may be burned out by a laser beam, so when any laser equipment is being used, make

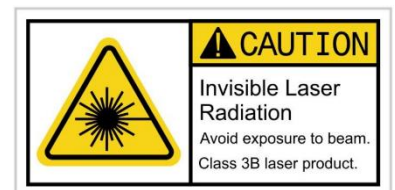

sure that the surface of the sensor not be exposed to the laser beam.

- Mount laser dome camera at a height of six meters (19.7 ft) from the ground. To avoid bodily injury from the laser radiation, please make sure that no one is within the range of three meters (9ft) from the camera when the laser is working.
- Never look at operating laser while the power is on.
- **Caution:** Use of controls or adjustments to the performance or procedures other than those specified herein may result in hazardous laser emissions.

Maintenance Precautions:

- If there is dust on the front glass surface, remove the dust gently using an oil-free brush or a rubber dust blowing ball.
- If there is grease or a dust stain on the front glass surface, clean the glass surface gently from the center outward using anti-static gloves or an oil-free cloth. If the grease or the stain still cannot be removed, use anti-static gloves or an oil-free cloth dipped with detergent and clean the glass surface gently until it is removed.
- Do not use organic solvents, such as benzene or ethanol when cleaning the front glass surface.

Regulatory Compliance

FCC Part 15

This equipment has been tested and found to comply with the limits for digital device, pursuant to part 15 of the FCC Rules. These limits are designed to provide reasonable protection against harmful interference when the equipment is operated in a commercial environment. This equipment generates, uses, and can radiate radio frequency energy and, if not installed and used in accordance with the instruction manual, may cause harmful interference to radio communications. Operation of this equipment in a residential area is likely to cause harmful interference in which case the user will be required to correct the interference at his own expense. This product complies with Part 15 of the FCC Rules. Operation is subject to the following two conditions: This device may not cause harmful interference.

This device must accept any interference received, including interference that may cause undesired operation.



LVD/EMC Directive

This product complies with the European Low Voltage Directive 2006/95/EC and EMC Directive 2004/108/EC.



WEEE Directive–2002/96/EC

The product this manual refers to is covered by the Waste Electrical & Electronic Equipment (WEEE) Directive and must be disposed of in a responsible manner.

Overview

Model Numbers

This user guide is suitable for the following models:

If letter “B” or “S” is included in the middle within the model number, means:

1. “B” - B Class – Use for ProAV, Broadcast applications, SDI video format 1080p and 1080i supported, frame rate up to 60/59.94; supports Visca-Over-IP control.
2. “S” – S Class – Use for video surveillance or other applications, SDI video format 1080p and 720p supported, frame rate up to 60; Does not support Visca-Over-IP.

- EX1030SHD-B-LSN2P1 (SDI+IP, B Class)
- EX1030SHD-S-LSN2P1 (SDI+IP, S Class), (For Special Order Only)
- EX1030SHD-B-LSA1 (SDI, B Class), (For Special Order Only)

Features

- Resolution: Up to 1080P60, 1080i59.94
- IP Resolution: Up to 1080P60, 1080P30
- Video Compression: H.264/H.265/MJPEG
- Video Output: SDI+IP, True Dual-Output SDI+IP Simultaneously
- Zoom: Optical 30X, 12x Digital Zoom
- Low latency Mode and Image stabilizer and true WDR 130dB
- Various Image Functionalities: WDR, BLC, Defog, Day/Night
- ±360-degree continuous pan, ±120-degree tilt, adaptive speed up to 90°/s
- 128 presets, Presets speed adaptive up to 80°/s, 8 Cruises
- Control supports RS-232 control, RS-422/485 control, VISCA-over-IP, IP-Onvif.
- Presets store camera directions and image parameters (iris, white balance, exposure, image settings).
- Image parameter setting restore with presets and quick access operation
- IP Protocol RTSP, RTMP for online video streaming.
- 3D Positioning
- Adaptive IR laser illumination distance up to 500 Meters
- Outdoor Environmental Rating: IP67, Corrosion Resistant Treatment, Nitrogen Filled Housing
- Input Power: Provides 24VAC, ±24VDC and high power POE (IEEE802.3bt)
- Working temperature: -40°C to 60°C
- Nitrogen Filled Housing
- Resistance to wind: 60m/s.
- Explosion Protection Level: IEC/IECEX, Ex nR IIB T4 Gc
- Firmware upgrade via IP

WHAT'S IN THE BOX

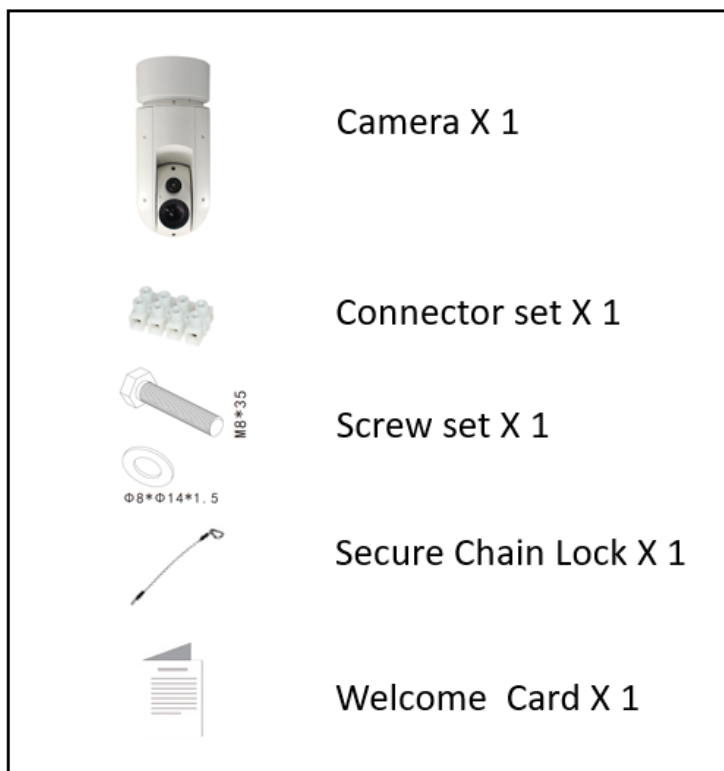

Accessories- Optional



Camera Diagram

Camera



Tail-Cable

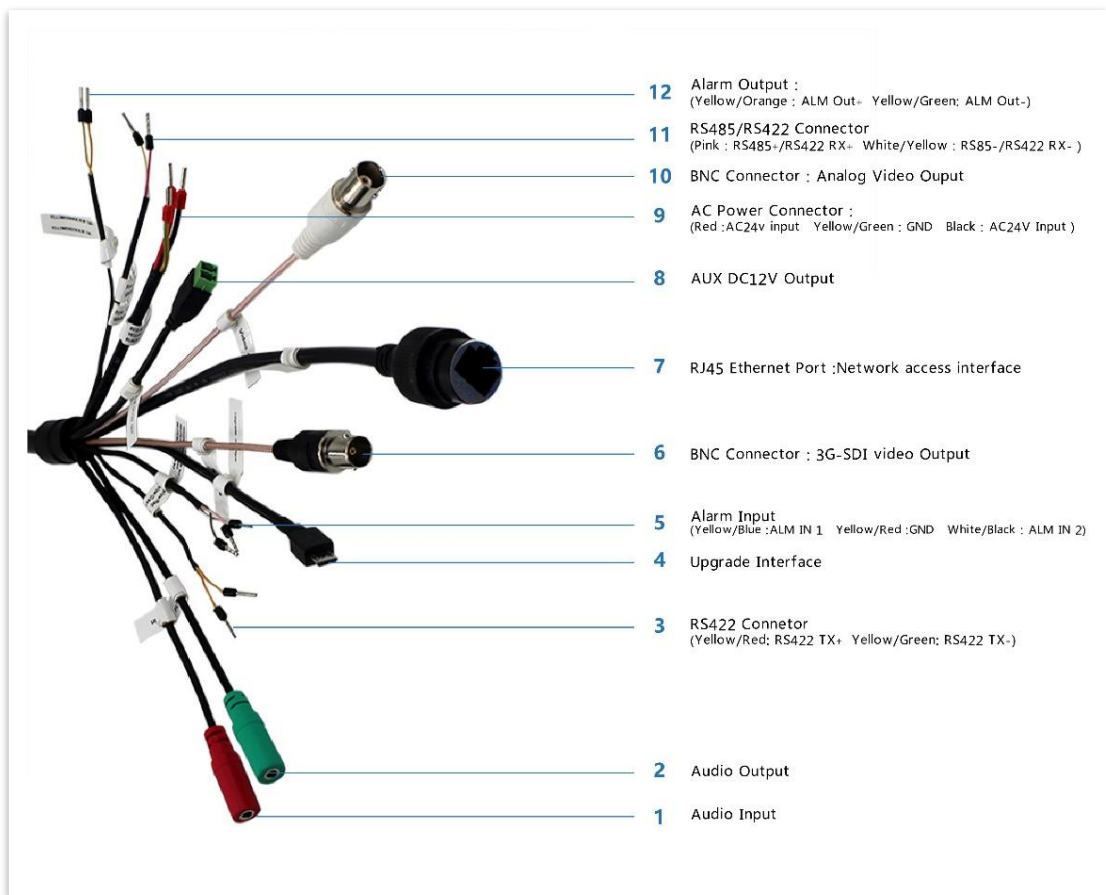

All cables are labelled to show their functions separately. The tail-cable individual feature availability may vary with the specific product model number.

System Connection Diagram

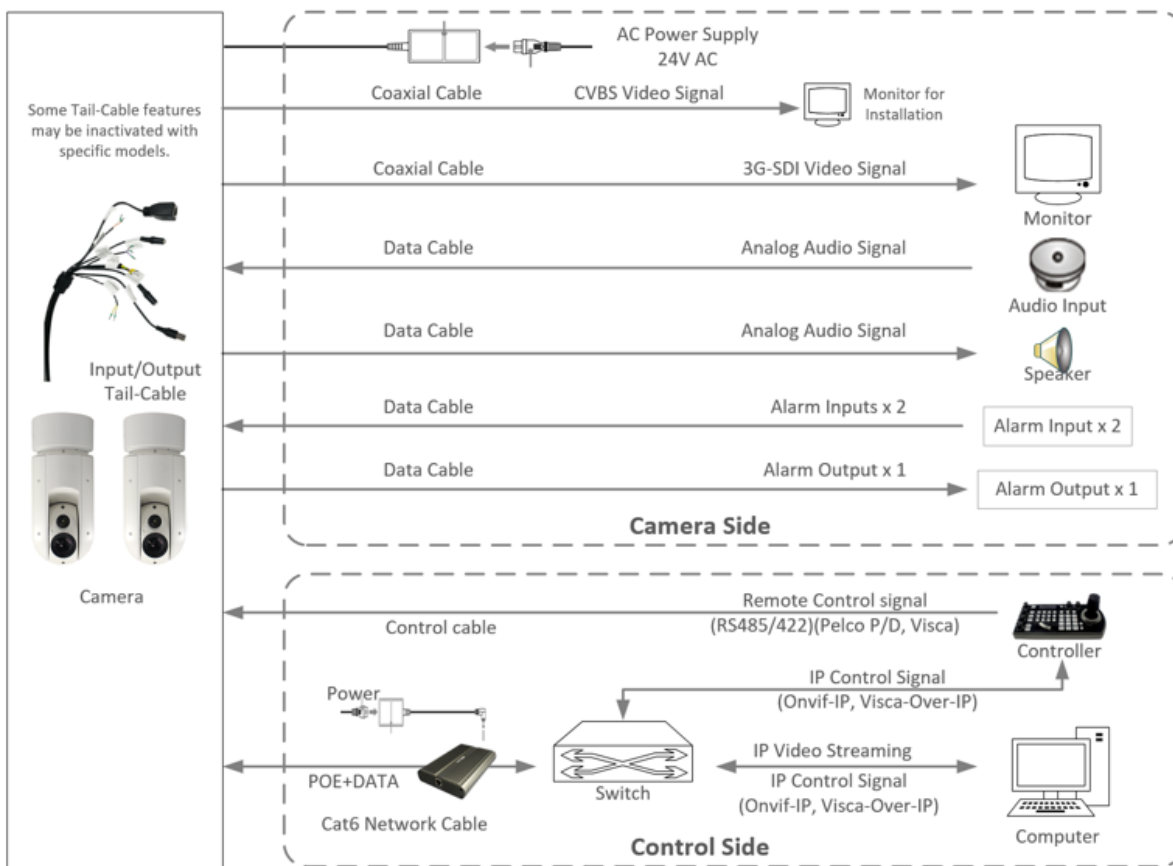

NOTE!

Use water proof / IP67 rated junction box/ connection box to protect the RJ45 and other connections. A water proof RJ45 connector is included.

Installing Your Camera

The following diagrams are for your reference only. See the actual product to mount your camera.

Check Camera Components and Installation Conditions

Before mounting your camera, check the device model number and included contents against the packing list to ensure components are complete.

Camera Structure

1. Tail-Cable
2. Camera Body

Important

- Verify the bearing capacity of the mounted position
- Verify that the mounted position meets the bearing requirements. Otherwise, you are advised to reinforce the mounted position for the device weight. For more information, see the product datasheet.
- Verify lightning protection and grounding requirements
- Select proper lightning protection devices for the power supply, video signal interfaces, and RS422/485 interfaces.
- Ground the terminal properly.

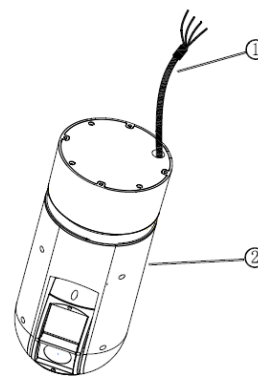

Cable Requirements

Network cable

10/100 Mbps Ethernet CAT 5/5E/6 UTP cables are applicable to the ANSI/EIA/TIA-568A/B and ISO/D. Eight wires in the network cable need to be inserted in parallel into the top of the cable connector. The cable connector needs to be crimped in position. When the cable connector is in position, ensure that the metal pieces of the cable connector are parallel to each other and the clamp of the cable connector is intact.

SDI Signal Cable

In order to ensure the quality of the installation of the project, the HD-SDI and 3G-SDI signals have a high data transmission rate of digital signals, it is necessary to correctly select the appropriate cable model. In the process of installing a cable, it should be carefully, to avoid incorrect to fold, twist, bend the cable or to apply various kinds of stress to the cable, so that the signal can be transmitted smoothly.

Different types of cable have different physical and electrical characteristics, and the transmission length of the digital signal is not the same.

| Recommended cable | Transmission signal | Transmission distance |
|-------------------------------------|---------------------|-----------------------|
| Belden 7731A | 3G-SDI | 120 m |
| 128 above the double shield 75-5 | HD-SDI | 70 m |

SDI cable suggested:

- SDI Cable: For broadcast use, Belden1694A/5CFB is a suitable cable to transmit broadcast-quality video:

1694A

COAXIAL CABLES

6.44

Precision Video Cable for Analog and Digital

RG-6/U and RG-11/U Type



| Description | Part No. | UL NEC/ C(UL) CEC Type | Standard Lengths | | Standard Unit Weight | | Conductor (stranding) Diameter Nom. DCR | Nominal Core OD | | Shielding Materials Nom. DCR | Nominal OD | | Nom. Imp. (Ω) | Nom. Vel. of Prop. | Nominal Capacitance | | Nominal Attenuation | | |
|--|--------------|------------------------------|------------------|--------|----------------------|------|---|-----------------|------|------------------------------|------------|------|---------------|--------------------|---------------------|------|---------------------|-----------|---------|
| | | | ft. | m | Lbs. | kg | | Inch | mm | | Inch | mm | | | pF/ft. | pF/m | MHz | dB/100 Ft | dB/100m |
| RG-6/U Type • 18 AWG Solid .040" Bare Copper Conductor • Duofoil® (100% Coverage) + Tinned Copper Braid Shield (95% Coverage) | | | | | | | | | | | | | | | | | | | |
| Gas-injected Foam HDPE Insulation • PVC Jacket (Available in 10 colors)* | | | | | | | | | | | | | | | | | | | |
| SDI/HDTV | 1694A | NEC: | 500* | 152.4 | 20.5 | 9.3 | 18 AWG | .180 | 4.57 | Duofoil + 95% | .275 | 6.99 | 75 | 82% | 16.2 | 53.1 | 1 | .2 | .8 |
| Digital Video | | CMR: | 1000 | 304.8 | 45.0 | 20.5 | (solid) | | | TC Braid | | | | | | | 3.6 | .5 | 1.5 |
| 75°C | | CEC: | 4500 | 1371.6 | 202.5 | 91.9 | .040" | | | 2.852/M' | | | | | | | 10 | .7 | 2.4 |
| | | CMG FT4 | | | | | BC | | | 2.852/M' | | | | | | | 71.5 | 1.6 | 5.2 |
| | | | | | | | 6.452/M' | | | 9.242/km | | | | | | | 135 | 2.1 | 6.9 |
| | | | | | | | 21.052/km | | | | | | | | | | 270 | 3.0 | 9.7 |
| | | | | | | | | | | | | | | | | | 360 | 3.4 | 11.3 |
| | | | | | | | | | | | | | | | | | 540 | 4.3 | 13.9 |
| | | | | | | | | | | | | | | | | | 720 | 4.9 | 16.1 |

Conductor:

| AWG | Stranding | Material | Nominal Diameter |
|-----|-----------|-------------|------------------|
| 18 | Solid | Bare Copper | 0.04 in. |

Shield Material

| Type | Layer | Material | Coverage |
|-------|-------|---------------------------------|----------|
| Tape | 1 | Aluminum / Polyester / Aluminum | 100% |
| Braid | 2 | Tinned Copper | 95% |

| Nom. Capacitance Conductor to shield | Nom. Inductance | Nom. Char. Impedance |
|---|-----------------|----------------------|
| 16.2 pF/ft | 0.106 μH/ft | 75 Ohm |

Power Input

This camera provides 24VAC power input, as well as 24VDC not “+/-” sensitive.

Power consumption

The peak power consumption on camera is 89W, when fully loaded operation is performed, means when controlling the camera in cold weather (heater on) at night (IR on) and moving pan tilt zoom in high speed.

- 24VAC 5Amp power is required for having stable camera performance.
- 24VAC is measured on the end of camera side for the camera power input, long distance power transmit may cause power voltage dropping down. Please calculate the power on the end of camera accordingly with the cable you are using for the distance the power will run.
- Please take reference of the power/cable/distance table below.

Power Cable

Data listed in the below table is applicable to copper cables that use 24 VAC/24 VDC power supply. The item Core Diameter indicates the conductor diameter.

24 Volt Wire Length Calculator Table

The recommended maximum distances for 24volts, AC or DC, is the cell below the wire size, adjacent to watts (VA) or required current.

| Distance (ft) W(VA)/Amps | Cable Size (Gauge/awg)/Diameter(mm) | | | | | | | | | |
|-----------------------------|-------------------------------------|-----------------|-----------------|-----------------|-----------------|-----------------|-----------------|-----------------|-----------------|----------------|
| | 8awg 3.26mm | 10awg 2.59mm | 12awg 2.05mm | 14awg 1.63mm | 16awg 1.29mm | 18awg 1.02mm | 20awg 0.81mm | 22awg 0.64mm | 24awg 0.51mm | 26awg 0.4mm |
| 3VA(.13A) | 14417 | 9253 | 5823 | 3656 | 2299 | 1451 | 905 | 565 | 358 | 226 |
| 10VA(.42A) | 4463 | 2864 | 1803 | 1132 | 712 | 449 | 280 | 175 | 110 | 70 |
| 20VA(.83A) | 2258 | 1449 | 912 | 573 | 360 | 227 | 142 | 89 | 56 | 35 |
| 40VA(1.67A) | 1122 | 720 | 453 | 285 | 179 | 113 | 70 | 44 | 28 | 18 |
| 60VA(2.5A) | 750 | 481 | 303 | 190 | 120 | 75 | 47 | 29 | 29 | 12 |
| 80VA(3.33A) | 563 | 361 | 227 | 143 | 90 | 57 | 35 | 22 | 14 | 9 |
| 100VA(4.17A) | 449 | 288 | 182 | 114 | 72 | 45 | 28 | 18 | 11 | 7 |
| 120VA(5A) | 375 | 241 | 151 | 95 | 60 | 38 | 24 | 15 | 9 | 6 |
| 140VA(5.83A) | 321 | 206 | 130 | 82 | 51 | 32 | 20 | 13 | 8 | 5 |
| 160VA(6.67A) | 281 | 180 | 114 | 71 | 45 | 28 | 18 | 11 | 7 | 4 |
| 180VA(7.5A) | 250 | 160 | 101 | 63 | 40 | 25 | 16 | 10 | 6 | 4 |
| 200VA(8.33A) | 225 | 144 | 91 | 57 | 36 | 23 | 14 | 9 | 6 | 4 |

NOTE:

- *Important: Power supply requirement is 24VAC 5Amp to ensure proper functionality of PT motor and LED illumination. Using power supply lower than 24VAC 5Amp will cause camera crashing or insatiability.*
- *24VAC power adaptor is sold separately.*

Power Connector: Phoenix Connector Description

1. The anode and the cathode are not distinguished for phoenix connectors of red and black cables.
2. GND: yellow-green color.
Note: GND is used to ground the camera. Ensure that GND is connected to a reliable grounding point.

PoE Power Injector

Other than 24VAC power input, Bolin PTZ camera provides PoE power as an optional power input.

For PoE power, Bolin High Power PoE Injector: model BL-PP97 is highly suggested to be used. It provides high PoE power up to 97W. It is POE IEEE802.3bt compatible.

Connect this PoE injector to a network switch and then run Ethernet cable for data transmission and power up the PoE PTZ camera (Specific model: EX1000 & SD500 Series) for distance up to 100 meters.

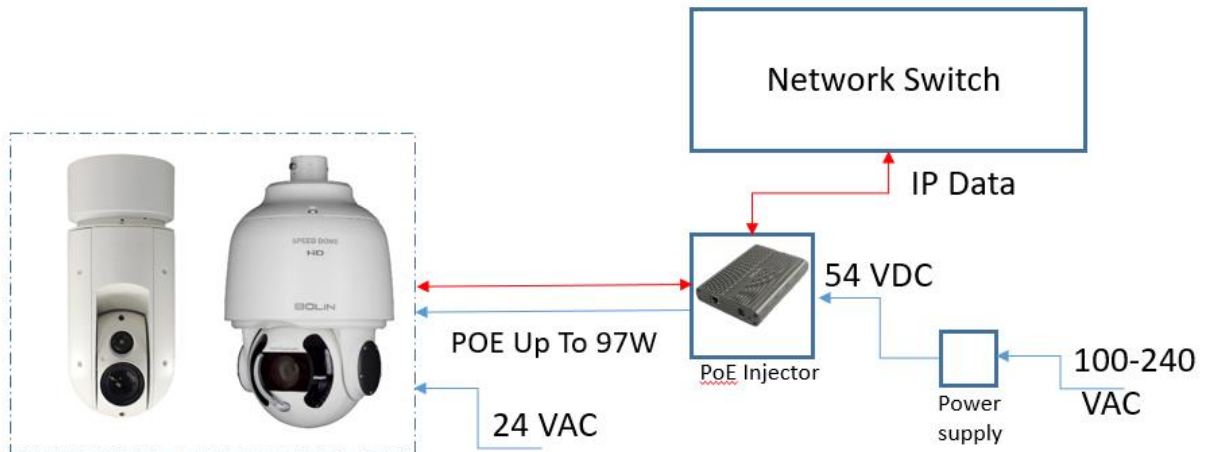

Camera Mounting

- Disconnect the power from the camera before camera installation.
- Accessories such as the wall mount bracket and the pendant mount bracket may be necessary during mounting. For the details, refer to the accessory list recommended by your dealer.
- The wall bearing capacity and the bracket length must meet all onsite mounting requirements. You will need to select a mount type based on the actual environment.
- When mounting the camera, please install the bracket adapter to the bracket first and then mount the camera to the bracket.
- Tighten all the screws to hold the camera securely.
- For waterproofing, apply sealant between the dome and the bracket, wall veneer slits, and leading-out holes of the wall.

Wall Mount

Need to use EX1000-WM wall mount for wall mounting. EX1000-WM is sold separately.

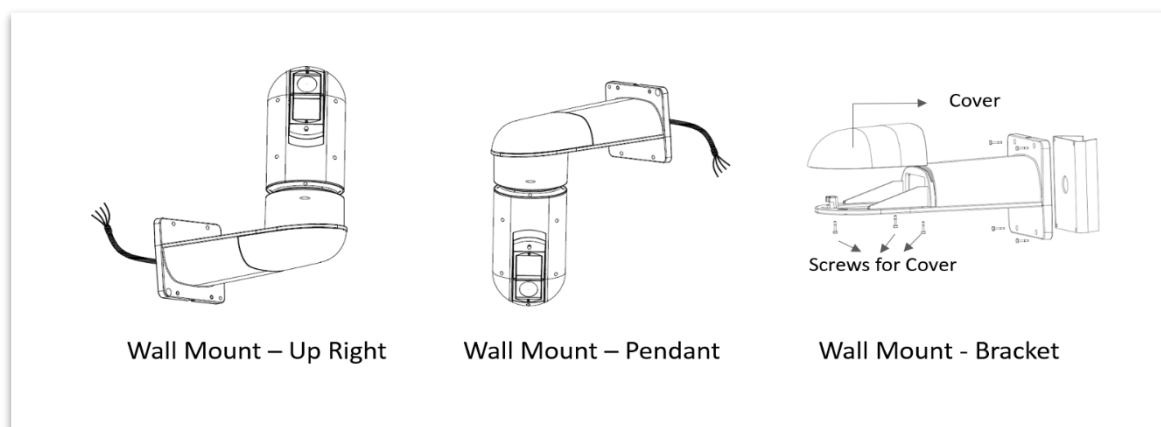

1. Open the bracket cover, mount it onto the wall or pole (use pole adaptor).
2. Put on 3 screws onto the bottom of the camera, leave enough space to fit in the screw holes on the bracket, not to screw tight.
3. Hold up the camera close under the bracket, insert the tail-cable of the camera into the chest of the bracket.
4. Insert the 3 screws into the screw holes and turn the camera counter-clock wise so that the camera can be held by the camera. Screw up the 3 screws but not too tight.
5. Put on the 4th screw and screw in tightly. Screw in the rest of the screws tightly.
6. Finish the cable connection. Put all cable and connectors inside of the bracket.
7. Put the cover back to the bracket and screw in securely.

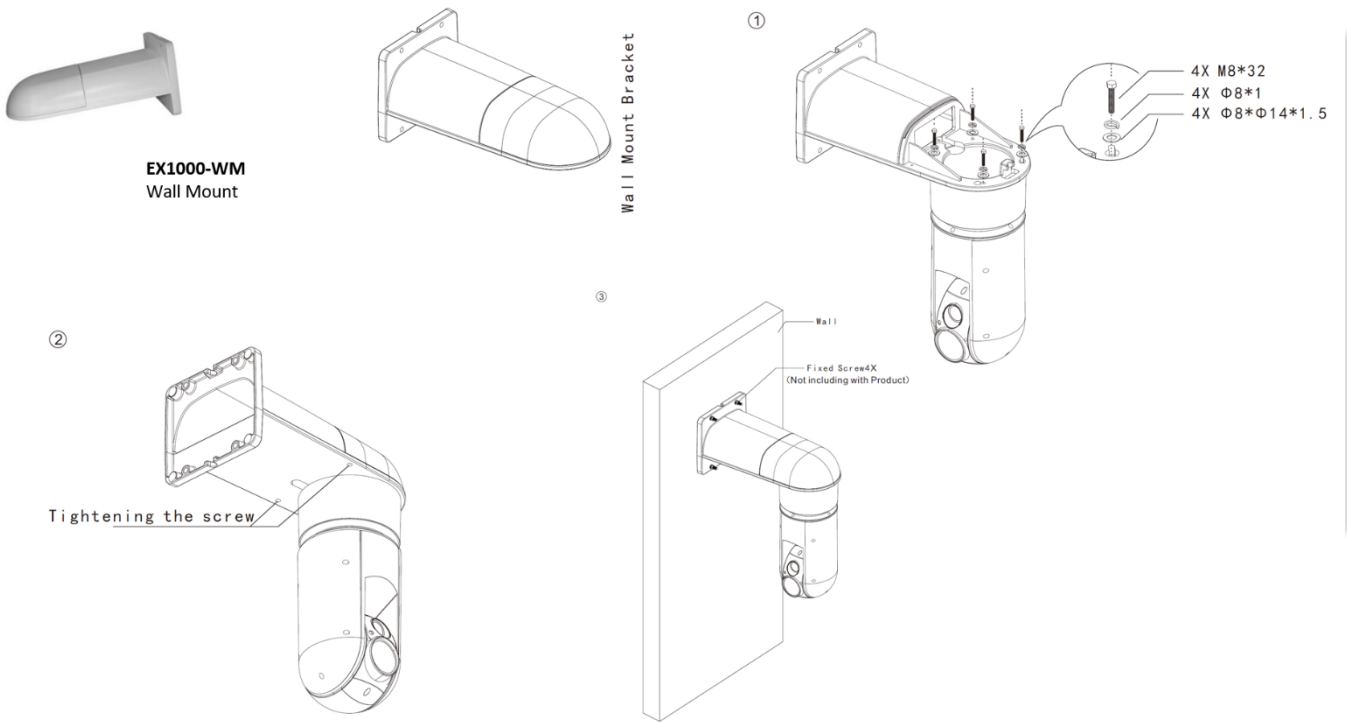

Ceiling Mount

Need to use BL-EX-CMS - Ceiling Mounting kit for EX1000, Includes BL-M-CMB, BL-M-CMH, BL-M-CMT. BL-EX-CMS is sold separately.

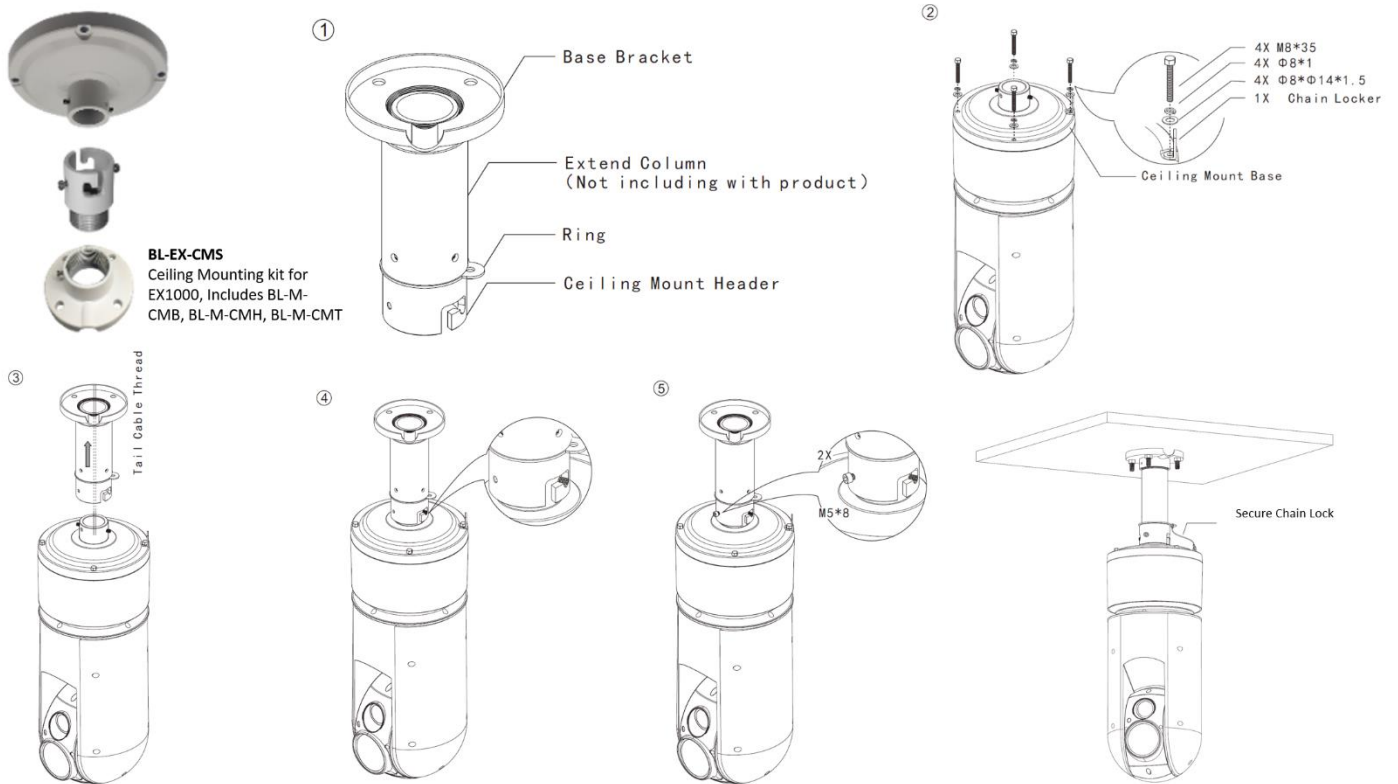

Base Mount

Need to use EX1000-MB Mounting base - Base Mounting kit for EX1000, can be mounted Pendant or Up-right.

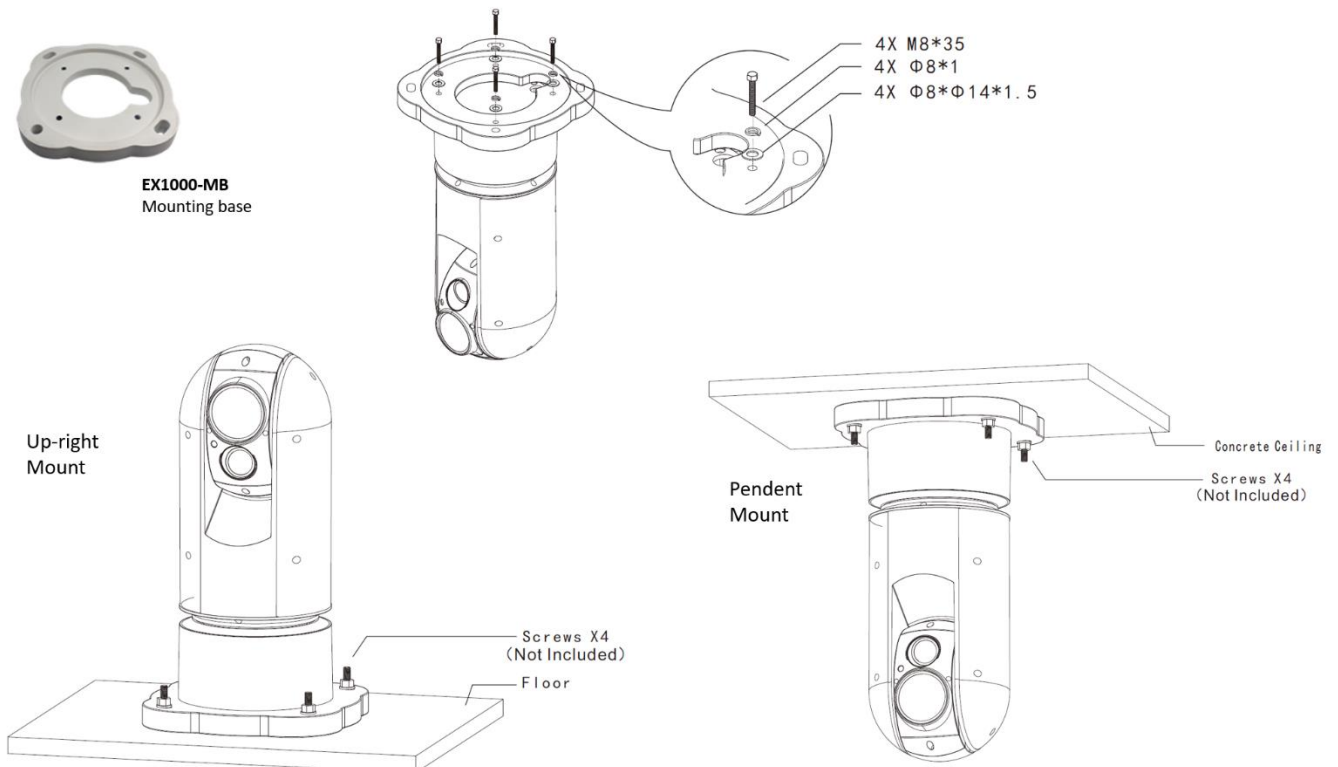

Pole Mount and Corner Mount

Need to use EX1000-WM and Pole/Corner Mount Adaptor – for mounting on pole or wall corner.



EX1000-WM
Wall Mount
BL-M-PMA
BL-M-CMA



BL-M-PMA
Pole Mount
Adaptor



BL-M-CMA
Corner Mount
Adaptor

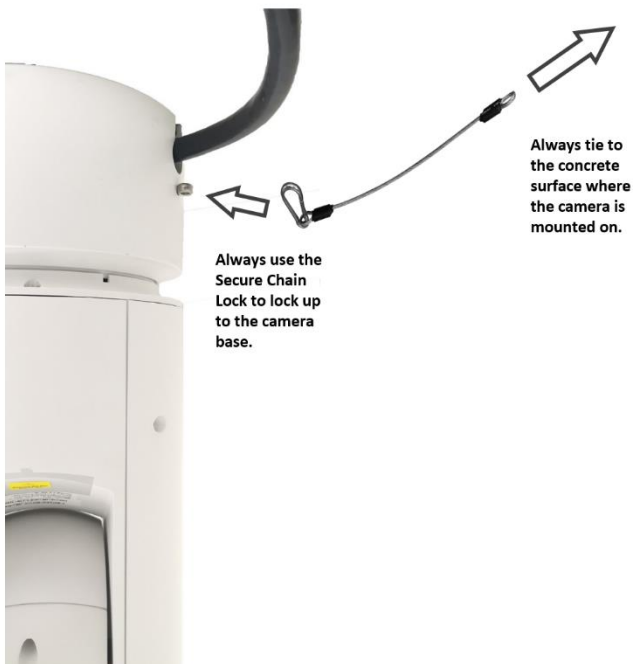
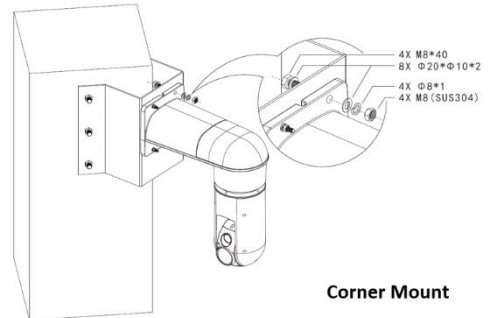
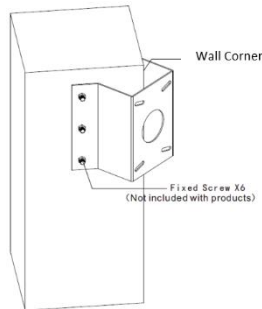
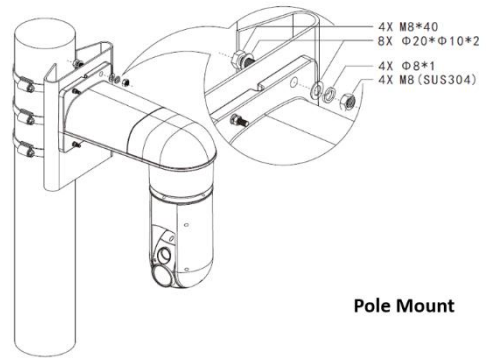
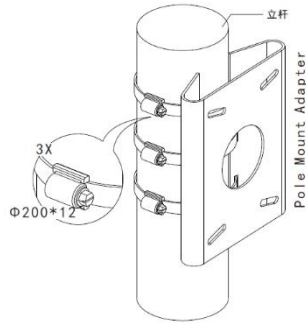

NOTE:

For safety concern, must always use the Secure Chain Lock (Included with the camera) to lock up from the camera base to the concrete surface where the camera is mounted on.

IR Laser Illuminator

Adaptive IR Laser Illuminator

The EX1000 PTZ series camera uses adaptive IR laser illuminator to provide up to 500 meters of long range illumination. IR laser uses diffused illumination that provide the long-distance visibility.

Precaution & Specs:

1. This product uses Class 3B laser light product.
2. Supports Manual / Auto IR laser control
3. Uses synchronous zoom with continuously adjustable illumination angle of $68^{\circ} \sim 2^{\circ}$.
4. Supports intelligent light-adjustment which automatically adjust the power of infrared laser light and avoids reflective object and close-range image overexposure.
5. Mount a laser dome camera at a height of six (6) meters (19.7 ft) from the ground. To avoid bodily injury from the laser radiation, please make sure that no one is within the range of three (3) meters (9 ft) from the camera when the laser is working.
6. When the IR laser is operating, do not look directly into the laser beam or obstruct the pathway of the beam.

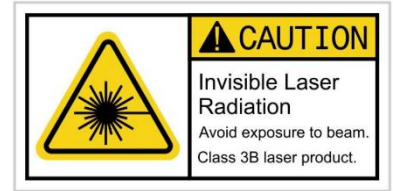

Everyone who uses a laser should be aware of the risks and take necessary caution when handling, operating and maintaining the product.

This camera can provide SDI video output, IP video output separately and SDI + IP video outputs simultaneously.

The following sections are the instructions of how to use SDI video output and how to use IP video output.

Use SDI video output

Starting the Camera

After you have mounted the camera properly, connect the camera to power.

Each time the camera is powered on, it will perform a self-test to check the Pan/Tilt/Zoom (PTZ function). After self-test, you can operate the camera.

- The camera will start initializing process after the camera is powered up. It may take 2-3minutes to finish the initializing.
- When the operating temperature is lower than zero degrees Celsius, the camera will be automatically pre-heat (the pre-heat process takes 30 minutes at most). The self-test starts only after the temperature rises above zero degrees Celsius.

Connect Camera to Monitor/SDI Device

To view your camera image, you need to use the coaxial cable to connect your camera to monitor or SDI device.

* The monitor/device must support the signal of HD-SDI or 3G-SDI.

Connect Camera with Controller

1. Connection

To control and configure your camera, you need to connect with control system (or control keyboard) for communication by RS-485/RS422. Set up the protocol of communication by control keyboard, the camera can auto detect VISCA and PELCO-D.

1.1 RS485 (PELCO D) control connection diagram

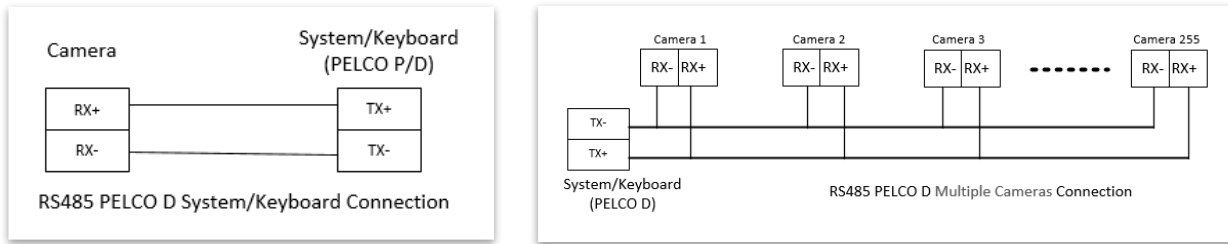

Connect the Camera's RS485+ and RS485 to RS485/TX+ and RS485/TX- on the control system/keyboard. The identity of the control system or equipment may be different; the corresponding relationship is as follows:

| | | | |
|----------|-----|-----------|----------|
| RS-485 A | RX+ | RS-485 D+ | RS-485 + |
| RS-485 B | RX- | RS-485 D- | RS-485 - |

1.2 RS422 (VISCA) control connection diagram

➤ SONY Keyboard RS422 Connection

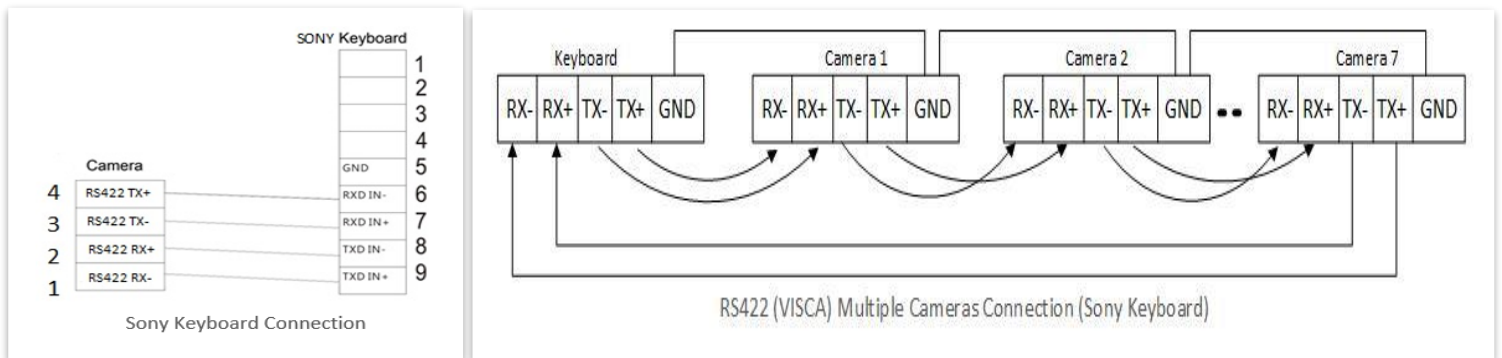

➤ VISCA (None-Sony) Keyboard RS422 Connection

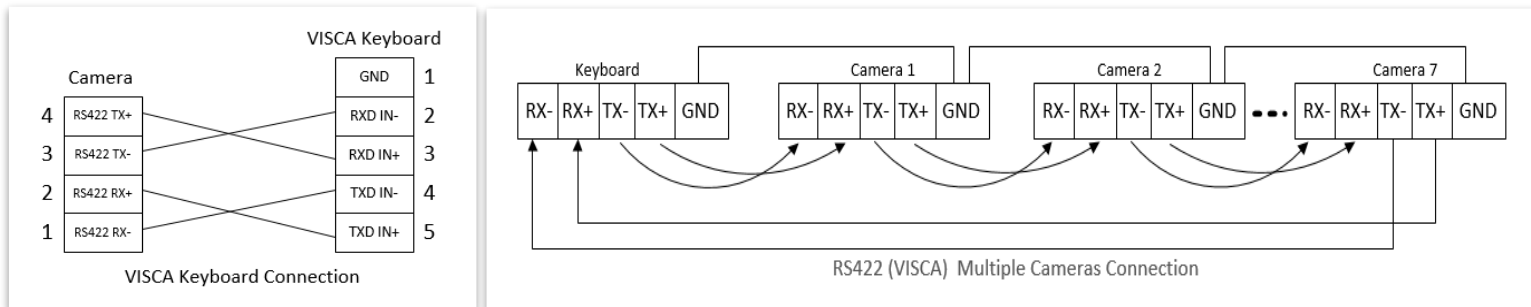

Control the camera - Setup Camera ID, Baud Rate and Control Protocol

This camera is a Dual Output camera which has SDI and IP output, so it provides SDI serial control (RS422-Visca and RS485-PelcoP/D) and IP(Onvif-IP and Visca-Over-IP) control methods.

In order for you to control this camera properly, the camera ID, baud rate and control protocol have to be set up correctly.

You need to know the camera Baud Rate and camera ID(address) that is being used with the camera you are going to setup control with.

If you don't know what the current baud rate and camera ID(address) that the camera is using, you can find the information by powering up the camera:

1. Connect the camera SDI video output with a SDI monitor.
2. Power up the camera, the camera will be doing initializing, it takes about few minutes.
3. There is an initial setting page displaying on the screen for 5 seconds when the camera is powered on finishes the initializing. Suggest taking a picture of this default setting information for keyboard setting use.
4. On the page, it shows the factory default setting of the camera ID, baud rate, serial port and other information of the camera.

Make the control wire connection correctly between the camera and the keyboard. Visca and Pelco protocol can be supported. Follow the wire connection instruction for either Visca or Pelco protocol to make the connection. Make sure wire connection is corrected.

(How to make the connection, please refer to the camera user manual Part One)

Now, you are ready to setup control communication between the camera and the keyboard or control system.

5. Power up the camera, find the camera Baud Rate and camera ID(address). Follow the steps above.
 - a. Protocol between camera and keyboard controller and the wire connection method that has been made have to be the same.
6. On the keyboard controller/system, set the protocol (Visca or Pelco) same as the protocol wire connection you made for the control.
 - a. On camera side, protocol Visca or Pelco is auto detected by the wire connection has been made when the camera is powered on.
7. Set the keyboard Baud Rate same as the camera's.
 - a. Baud Rate setting with the camera and Baud Rate setting with the keyboard controller have to be the same.

If you are using a single SDI PTZ camera (No IP output), by now, the serial control has been successfully set up. you should be able to control the camera.

Select the camera ID (Camera Address that the camera is using, you can find it on camera OSD) on your controller, you can control the camera now.

If you are using a Bolin Dual Output SDI+IP PTZ camera (With IP output), go to camera IP web interface:

8. Connect the camera to your local network system switch/router.
9. Make the IP camera configuration and network configuration properly to start using the camera via IP, view the live view image via IP.
(How to make the camera IP connection and configuration, please refer to the camera user manual Part Two)
10. This camera is designed to auto-configure IP control interface with the SDI serial control as long as the camera IP address is connected. Don't need to match Baud Rate, Camera ID, Protocol between IP interface and SDI Interface.
11. Once you can login to the camera via web browser interface, you can control the camera via IP interface.

Now, you can start controlling the camera by either using serial controller or the IP interface.

Note:

- For the first time setting, you must match the controller's camera DI(Address) and Baud Rate to the camera's to make the first control communication work. After the correct control has been built up, you can change the camera setting as you like, as long as you match the setting on both side at the end.
- Camera supports VISCA and PELCO-D protocols, protocol is detected automatically by the camera.
- Factory Default Setting: For both SDI and IP video, Baud Rate: 9600, Camera ID: 001, Pelco Protocol.
- Use RS485 Pelco-D can control up to 255 cameras, camera ID from 001 to 255 has to be set.
- Use RS422 VISCA protocol can control up to 7 cameras, camera ID from 1 to 7 has to be set.
- Supports baud rate of 2400bps, 4800bps, 9600bps and 38400bps.
- How to set up the address and baud rate of the camera for SDI and IP, please see the camera user manual Part One and Part Two.
- How to set up the address and baud rate of the Bolin keyboard for SDI and IP, please see the relevant controller user manual.

NOTE:

The operation of the control systems or devices of different makers may be different. To operate the camera, please refer to the manual of the control system or the device.

Adjusting and Setting with Menus

About On-Screen Menus

You can change various settings, such as shooting conditions and system setup of the camera, while observing menus displayed on a connected computer screen.

This section explains how to read the on-screen menus before starting menu operations.

The menu parameters may vary according to the different product model numbers.

For a complete configuration menu, see "Menu Configuration".



NOTE!

You cannot perform pan/tilt operations while the menu is displayed.

How to adjusting and setting by joystick of keyboard

1. Push the joystick of the keyboard to the up or down: To select the menu that you want.
2. Push the joystick of the keyboard to the right: To enter the menu that you want.
3. Push the joystick of the keyboard to the right: To confirm the value that you want to set to.

Run preset 95th using keyboard to call/display the On-Screen Menu, the main menu will display on the screen.

How to run presets of cameras, please refer to the manual of the keyboard/control system that you are using.

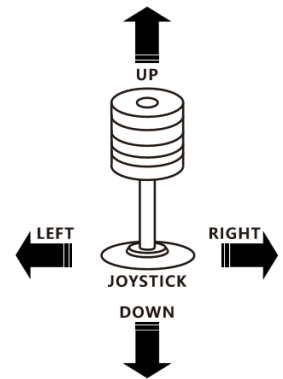

The On-Screen Menu Configuration

When the camera runs with Pelco-D protocol, Call preset 95 to enter the On-Screen Menu by using control keyboard, the main menu will display on the screen.

When the camera runs with VISCA protocol, press [menu] button on VISCA control keyboard to enter the OSD Menu.

You can also operate the camera OSD menu via IP web interface. Please refer the user manual part two.

EXPOSURE Menu

The EXPOSURE menu is used to set the items related to exposure.

FULL AUTO: The exposure is adjusted automatically using the sensitivity, electronic shutter speed, and iris.

MANUAL: Adjust the sensitivity (GAIN), electronic shutter speed (SPEED) and iris (IRIS) manually.

When you select one from various exposure modes, some of the following setting items that are required for the selected mode appear.

IRIS PRIOR: Iris Priority mode. The exposure is adjusted automatically using the sensitivity and electronic shutter speed. Adjust the iris (IRIS) manually.

SHUTTER: Shutter mode. The exposure is adjusted automatically using the sensitivity and iris. Adjust the electronic shutter speed (SPEED) manually.

BRIGHT: Adjust the brightness level (LEVEL) manually. Select the brightness level from 0 to 31.

When you select one from various exposure modes, some of the following setting items that are required for the selected mode will appear.

GAIN: Select the gain from the following: 0dB, 3.6dB, 7.1dB, 10.7dB, 14.3dB, 17.8dB, 21.4dB, 25dB, 28.6dB, 32.1dB, 35.7dB, 39.3dB, 42.8dB, 46.4dB and 50dB.

SHUTTER: Select the electronic shutter speed from the following: 1/1, 1/2, 1/4, 1/8, 1/15, 1/30, 1/60, 1/90, 1/100, 1/125, 1/180, 1/250, 1/350, 1/500, 1/725, 1/1k, 1/1.5k, 1/2k, 1/3k, 1/4k, 1/6k, 1/10k.

IRIS: Select the iris from the following: CLOSE, F1.6, F2.0, F2.4, F2.8, F3.4, F4, F4.8, F5.6, F6.8, F8, F9.6, F11, F14

BACKLIGHT MODE:

When the background of the subject is too bright, or when the subject is too dark due to shooting in the AE mode, back light compensation will make the subject appear clearer.

This can be set to ON/OFF.

DEFOG:

Defog: ON, OFF. If the shooting scene has fog, you can open the defog function to improve the penetration of the image.

EX-COMP (Exposure Compensation):

When MODE is set to one of FULL AUTO, SHUTTER, IRIS PRIOR or BRIGHT, set this item to ON to enable exposure compensation. When you set EX-COMP to ON, EX-COMP LEVEL can be configured.

EX-COMP LEVEL: Level can be selected from the following: -10.5dB, -9dB, -7.5dB, -6dB, -4.5dB, -3dB, -1.5dB, 0dB, +1.5dB, +3dB, +4.5dB, +6dB, +7.5dB, +9dB, +10.5dB

If you set the level to 0, exposure compensation will be disabled. Level +10.5 is the brightest and -10.5 is the darkest compensation value.

When EX-COMP is set to OFF, exposure compensation does not function.

HIGH SENSITIVITY:

In this mode, the maximum gain increases, enabling to obtain a brighter output even in a darker environment. However, if the gain reaches high level, the image will have a large amount of noise.

SLOW AE (AUTO EXPOSURE)

The slow AE Response function allows you to reduce the exposure response speed. Usually the camera is set

up so that the optimum exposure can be obtained automatically within about 1 second. However, using the slow AE response function allows you to lengthen the auto exposure response speed from the initial setup speed (01h) to approx. 10 minutes (30h) (at normal shutter speed).

SLOW SHUTTER:

Slow shutter: ON, OFF. When AUTO SLOW SHUTTER is set to on, it can auto adjust the electronic shutter speed.

GAIN LIMIT: The gain limit can be set at Full Auto, Manual, IRIS PRIOR, Shutter and Bright mode. Use this setting when you want to obtain image in which signal-to noise ratio is particularly important.

Select the gain limit from the following: 10.7dB, 14.3dB, 17.8dB, 21.4dB, 25dB, 28.6dB, 32.1dB, 35.7dB, 39.3dB, 42.8dB, 46.4dB and 50dB

Min. SHUTTER LIMIT (Minimum Shutter Limit)

When the subject becomes dark, the shutter speed becomes slow and the gain is increased. This is a function to put a limit on the shutter speed. It prevents the camera shake when you shoot a moving subject in a dark

OSD

| |
|------------------|
| >EXPOSURE |
| WHITE BALANCE |
| PICTURE |
| LENS PARAMETERS |
| SYATEM SETUP |
| FUNCTION SETTING |
| SAVE AND EXIT |
| EXIT |

EXPOSURE

| |
|---------------------|
| AE MODE: FULL AUTO |
| IRIS: N/A |
| GAIN: N/A |
| SHUTTER: N/A |
| BRIGHT: N/A |
| BACKLIGHT MODE: OFF |
| DEFOG: OFF |
| EX-COMP MODE: ON |
| EX-COMPLEVEL: 0DB |
| NEXT PAGE |
| EXIT |

OSD

| |
|------------------|
| >EXPOSURE |
| WHITE BALANCE |
| PICTURE |
| LENS PARAMETERS |
| SYATEM SETUP |
| FUNCTION SETTING |
| SAVE AND EXIT |
| EXIT |

EXPOSURE

| | |
|-------------------|-------|
| HIGH SENSITIVITY | OFF |
| SLOW AE | I |
| SLOW SHUTTER | OFF |
| GAIN LIMIT | 50dB |
| MIN.SHUTTER MODE | OFF |
| MIN.SHUTTER LIMIT | 1/125 |
| EXIT | |

place.

EXIT: Push the joystick to the right to exit this level menu.

WHITE BALANCE Menu

The WHITE BALANCE menu is used to select the white balance mode.

MODE (white balance mode): Select the white balance mode from the following:

AUTO: This mode computes the white balance value output using color information from the entire screen. It outputs the proper value using the color temperature radiating from a black subject based on a range of values from 2500K to 7500K. This mode is the initial setting.

IN DOOR: 3200K Base Mode.

OUT DOOR: 5800K Base Mode.

OPW (One Push White Balance): The One Push White Balance mode is a fixed white balance mode that may be automatically readjusted only at the request of the user (one push trigger), assuming that a white subject, in correct lighting conditions, and occupying more than 1/2 of the image, is submitted to the camera. One Push White Balance data is lost when the power is turned off, if the power is turned on again, need to reset OPW.

ATW (Auto Tracing White Balance): Auto Tracking White Balance (2000K to 10000K), allows the camera to adjust the tone according to the temperature of the light source illuminating the subject.

SVL OUTDOOR AUTO (Sodium Vapor Lamp Outdoor Auto): This is an auto white balance mode specifically for outdoors, which is compatible with sodium vapor lamps.

SVL (Sodium Vapor Lamp): This is a fixed white balance mode specifically for sodium vapor lamps.

SVL AUTO (Sodium Vapor Lamp Auto): This is an auto white balance mode that is compatible with sodium vapor lamps.

USER: This is a mode that enables you to manually set the control of R and B gain up to 256 steps.

When you select USER, R. GAIN (red gain) and B. GAIN (blue gain) appear. You can select each item in the range from 0 to 255.

EXIT: Push the joystick to the right to exit this level menu.

OSD

| |
|------------------|
| EXPOSURE |
| >WHITE BALANCE |
| PICTURE |
| LENS PARAMETERS |
| SYSTEM SETUP |
| FUNCTION SETTING |
| SAVE AND EXIT |
| EXIT |

WHITE BALANCE

| |
|---------------------|
| MODE: USER |
| USER DEFINED R: 203 |
| USER DEFINED B: 213 |
| EXIT |

PICTURE Menu

The PICTURE menu is used to set the items related to the picture.

SHARPNESS:

EFFECT: (Picture Effect)

It consists of the following functions:

- Neg. Art: Negative/Positive Reversal
- Black & White: Monochrome Image
- Image effect from Off, B&W, NEG.ART

COLOR GAIN:

You can configure the color gain from 0 to 14. Use this setting when bright color is particularly important.

COLOR HUE:

You can adjust color phase from 0 to 14.

FLIP:

Image E-Flipper-Used when ceiling mounting or upright mounting. Set to OFF is upright mode, set to ON is for ceiling mount.

MIRROR:

You can have the image as seen in a mirror, with the right side as though it were the left.

OSD

| |
|------------------|
| EXPOSURE |
| WHITE BALANCE |
| >PICTURE |
| LENS PARAMETERS |
| SYSTEM SETUP |
| FUNCTION SETTING |
| SAVE AND EXIT |
| EXIT |

PICTURE

| | |
|-------------------|-----|
| SHARPNESS 8 | |
| EFFECT | OFF |
| COLOR GAIN 5 | |
| COLOR HUE 6 | |
| FLIP | OFF |
| MIRROR | OFF |
| NOISE REDUCTION | OFF |
| STABILIZER | OFF |
| GAMMA | 0 |
| GAMMA OFFSET | 0 |
| Low-Illum. Chroma | |
| DE-FLICKER | OFF |
| WDR | OFF |
| EXIT | |

NOISE REDUCTION:

The NR function removes noise (both random and non-random) to provide clearer images. This function has six steps: levels 1 to 5, plus off. The NR effect is applied in levels based on the gain, and this setting value determines the limit of the effect. In bright conditions, changing the NR level will not have an effect. When it is set to level 7Fh, you can set NR of 2D/3D individually.

2D:

2D Noise Reduction is a method of reducing noise within an image by comparing frame-to-frame, removing the variations that do not appear in each frame.

3D:

3D Noise Reduction is a method of reducing noise by comparing variances within the same frame, as well as comparing frame-to-frame. This will reduce noise without leaving trails behind a moving object.

STABILIZER:

When the image stabilizer function is set to ON, you can obtain the image with less screen blur caused by shaking. The correction effect can be achieved at the vibration frequency around 10 Hz. The image stabilizer function uses the digital zoom method. Although there are changes in the angle of view and resolution, the sensitivity is maintained.

NOTE:

Stabilizer feature will be disabled when Low Latency Mode is set to ON.

GAMMA:

You can adjust the gamma value as 0 or 1.

GAMMA OFFSET:

You can choose the offset of the output level of gamma curves. Choose a value from -49 to -64, and 0 to +64.

LOW-ILLUM. CHROMA:

You can configure a Chroma suppress mode for low illumination conditions. This can be useful when color noise is particularly noticeable in such conditions. Four levels (disabled and three levels) are available for the low-illumination Chroma suppress mode.

You can set the brightness from OFF, 3, 2, 1

WDR (Wide dynamic range mode):

Wide Dynamic: ON, OFF. The camera distinguishes light and dark areas within the same scene, adjusts the brightness for dark areas, and also controls the blown-out highlights.

You can select the wide dynamic range mode between ON and OFF.

EXIT: Push the joystick to the right to exit this level menu.

LENS PARAMETERS Menu

The LENS PARAMETERS menu is used to set the items related to the lens.

ZOOM:

Digital zoom:

ON, OFF. When DIGITAL ZOOM is set to on, it can use the digital zoom.

NOTE:

Digital Zoom feature will be disabled when Low Latency Mode is set to ON.

ZOOM OSD DISPLAY:

Zooming number of times will be displayed on the screen.

AUTO FOCUS:

AF SENSITIVITY:

- Normal

Reaches the highest focus speed quickly, this is the most appropriate mode.

- Low

Improves the stability of the focus. When the lighting level is low, the AF function does not take effect, even though the brightness varies, contributing to a stable image.

AF MODE:

- Normal AF Mode

OSD

| |
|------------------|
| EXPOSURE |
| WHITE BALANCE |
| PICTURE |
| >LENS PARAMETERS |
| SYSTEM SETUP |
| FUNCTION SETTING |
| SAVE AND EXIT |
| EXIT |

LENS PARAMETERS

| |
|------------------------|
| ZOOM: OFF |
| AUTO FOCUS |
| MANUAL FOCUS |
| NEAR LIMIT |
| JOYSTICK RECOVER: NONE |
| A/F RECOVER TIME: 000 |
| A/I RECOVER TIME: 000 |
| DAY/NITE MODE: NITE |
| LASER SETUP |
| ZOOMING SPEED: 8 |
| PRESET SPEED: 255 |
| EXIT |

This is the normal mode for AF operations.

- Interval AF Mode

The mode used for AF movements carried out at particular intervals. The initial setting for both is set to 5 seconds.

- Zoom Trigger Mode

When zoom position is changed, it becomes AF mode during the pre-set value (initial setting is set to 5 seconds). Then it stops.

MANUAL FOCUS

MF SPEED:

Fixed Speed: Speed of Manual Focusing is set to a fixed speed.

Variable Speed: Speed of Manual Focusing can be set to 1-8

JOYSTICK RECOVER:

NONE: No effect.

A/F: After operating the camera, the mode of focus be changed to auto form manual.

A/I: After operate the camera, the mode of IRIS be changed to auto form manual.

AF-AI: After operate the camera, the mode of focus be changed to auto form manual, and, the mode of IRIS be changed to auto form manual.

A/F RECOVER TIME:

When the camera is not in operation, if in the manual focus mode, after the A/F RECOVER TIME, it will automatically transfer to the automatic focus.

If the time is 0, then the function is closed.

A/I RECOVER TIME:

When the camera is not in operation, if in the manual Iris mode, after the A/I RECOVER TIME, it will automatically transfer to the automatic Iris.

If the time is 0, then the function is closed.

NEAR LIMIT:

The near limit from the following: 11cm, 30cm, 0.8m, 1.2m, 1.4m, 1.65m, 2m, 2.5m, 3.1m, 4.2m, 6m, 10m, 20m, OVER.

DAY/NITE MODE:

You can select the mode from AUTO, DAY and NIGHT.

When the camera is set to **AUTO** mode, the camera will automatically turn from Day mode (Color) to Night mode (Black & White) when the lighting condition is low enough, the camera illuminator will be turned on automatically at Night mode.

When the camera is set to **Day** mode, the camera will stay in Day mode (Color) no matter how low the lighting condition is, the camera illuminator will not be turned on at Night. The image may be too dark to be seen in a low light condition.

When the camera is set to **Night** mode, the camera will stay in Night mode (Black & White) no matter how bright the lighting condition is, the camera illuminator will be turned on all the time. The image will be stay in Black & White.

LASER SETUP:

You can turn on/off IR Laser illuminator

ZOOMING SPEED:

The speed of zooming can be set to value from 1 to 8.

PRESET SPEED:

The speed of preset operating can be set to value from 1 to 255.

EXIT: Push the joystick to the right to exit this level menu.

SYSTEM SETUP Menu

The SYSTEM SETUP menu is used to set the items related to the camera system.

FACTORY DEFAULT:

The menu is used to restore the factory settings.

DIRECTION INDICATOR:

Select ON to display the direction indicator on the screen.

INTERFACE SET:

This menu is used to set the following parameters:

CAMERA ID:

Factory Default Setting: 001

Use RS485 Pelco-D can control up to 255 cameras, camera ID from 001 to 255 has to be set.

Use RS422 VISCA protocol can control up to 7 cameras, camera ID from 1 to 7 has to be set.

BAUD RATE:

Factory Default Setting: 9600,

Select the baud rate from the following: 2400, 4800, 9600, 38400bps.

FACTORY FORMAT:

CAMERA ID: 001

BAUD RATE: 9600

LOW LATENCY:

The camera image performance can be set to Low Latency Mode to have the least image latency.

NOTE:

By setting the Low Latency Mode on, the Digital Zoom feature and Stabilizer feature will be disabled.

NOTE:

- After the camera ID and Baud rate is set, to activate the new set camera ID and Baud rate, the camera has to be rebooted by powering the camera OFF and ON.
- For Dual-Output camera, the camera ID and Baud rate on IP web interface is auto-adjusted with the camera ID and Baud rate setting on the SDI side.
- Once you modified and saved the camera ID and baud rate setting on camera side, please modify the corresponding parameters on the keyboard side, otherwise the camera and keyboard will be unable to communicate.

TITLE

User can set title to the camera through the TITLE menu, which is convenient to distinguish which camera it is. The set title will be overlay and displayed on both SDI and IP video image.

Follow the below steps to set the title (can set from both keyboard and IP web interface PTZ control panel):

1. Move the cursor to the TITLE menu
2. Move the keyboard joystick to the right (or click the right arrow on the PTZ control panel)
3. When the first character flashes, it means it can be modified currently, move the joystick up and down (or click the up/down arrow on the PTZ control panel) to select the character you want to set

NOTE: Selectable characters include numbers 1~9 and 0, capital letter A~Z and common symbols, such as @, +, /, *, _, (), etc.

4. After setting the first character, move the keyboard joystick to the right (or click the right arrow on the PTZ control panel), when the second character flashes, it means the second character can be modified.
5. After setting the title, move the keyboard joystick to the left (or click the left arrow on the PTZ control panel) until the first character does not flash, indicating that the title setting is done

NOTE: When the characters are displayed in white, meaning make it as blank, not set title character currently

TITLE DISPLAY

OSD

```

EXPOSURE
WHITE BALANCE
PICTURE
LENS PARAMETERS
>SYSTEM SETUP
FUNCTION SETTING
SAVE AND EXIT
EXIT
    
```

SYSTEM SETUP

```

FACTORY DEFAULT
DIRECTION INDICATOR
>INTERFACE SET
TEMPERATURE READING
SDI VIDEO: I080P30
PAN DIRECTION
TILT DIRECTION
PROPORTIONAL PT: ON
SET NORTH
SYSTEM INFO
SYSTEM RESET
EXIT

CAMERA ID: 001
BAUD RATE: 9600
FACTORY FORMAT
LOW LATENCY: OFF
TITLE
TITLE DISPLAY: OFF
EXIT
    
```

```

CAMERA ID: 001
BAUD RATE: 9600
FACTORY FORMAT
LOW LATENCY: OFF
TITLE: CAMERA-1
TITLE DISPLAY: OFF
EXIT
    
```

Title display switch, when set to ON, the set title will be displayed on both SDI and IP video, when set to OFF, the set title will not be displayed.

SDI VIDEO:

SDI + IP True Dual Output: You can have parallel SDI and IP video output. Either SDI or IP video format can be set up independently for having dual output simultaneously.

- SDI output: Select the SDI video output format from the following:
 B Class models: 1080P: 60/59.94/50/30/29.97/25; 1080I:60/59.94/50; 720P: 60/59.94/50/30/25.
 S Class models: 1080P: 60/50/30/25; 720P: 60/50/30/25.
- IP output: For IP video output, please refer to User manual part two.

Follow the steps to change the video format:

6. Set SDI video resolution in SYSTEM SETUP.
7. Select the SDI VIDEO format you want to have from 1080P: 60/59.94/50/30/29.97/25; 1080I:60/59.94/50; 720P: 60/50/30/25.
8. Waiting for a while for camera new set video format being taken. It is normal that you cannot take the control of the interface while the video format is being changed. You can reboot the camera by powering OFF and ON to active the new set video format if it takes too long to complete the format changing by itself.
9. Go to IP camera Web Interface (Refer to PART TWO- User Manual), you can set IP video resolution to following:

True Dual Output video format setting

This camera supports Bolin True Dual Output functionality, means that you can have relevant IP streaming when SDI/HDMI video is set to any format you want to set to. It takes SDI/HDMI video format setting as priority.

The following table chart shows the relationship between SDI/HDMI video format and IP video format.

Apply to Model: EX1000 Series True Dual Output PTZ Camera

| True Dual Output Video Format | | | | |
|-------------------------------|--------------------------|---------|--------|--------|
| SDI | IP Resolution/Frame Rate | | | |
| 1080p60 | 1080p60 | 1080p30 | 720p60 | 720p30 |
| 1080p59.94 | 1080p60 | 1080p30 | 720p60 | 720p30 |
| 1080p50 | 1080p50 | 1080p25 | 720p50 | 720p25 |
| 1080p30 | 1080p60 | 1080p30 | 720p60 | 720p30 |
| 1080p29.97 | 1080p60 | 1080p30 | 720p60 | 720p30 |
| 1080p25 | 1080p50 | 1080p25 | 720p50 | 720p25 |
| 720p60 | 1080p60 | 1080p30 | 720p60 | 720p30 |
| 720p59.94 | 1080p60 | 1080p30 | 720p60 | 720p30 |
| 720p50 | 1080p50 | 1080p25 | 720p50 | 720p25 |
| 1080i60 | 1080p60 | 1080p30 | 720p60 | 720p30 |
| 1080i59.94 | 1080p60 | 1080p30 | 720p60 | 720p30 |
| 1080i50 | 1080p50 | 1080p25 | 720p50 | 720p25 |
| 720p30 | 1080p60 | 1080p30 | 720p60 | 720p30 |
| 720p25 | 1080p50 | 1080p25 | 720p50 | 720p25 |

PAN DIRECTION:

Camera horizontal Left and right orientation setting, option: Normal/Invert

TILT DIRECTION:

Camera tilt up and down orientation setting, option: Normal/Invert

PROPORTIONAL PT:

Proportional pan automatically reduces or increases the pan and tilt speeds in proportion to the amount of zoom.

At telephoto zoom settings, the pan and tilt speeds will be slower for a given amount of joystick deflection than at wide zoom settings. This keeps the image from moving too fast on the monitor when there is a large amount of zoom.

Select ON: The bigger the camera lens is zoomed in, the slower the speed of Pan and Tilt would be. The smaller the camera lens is zoomed out, the faster the speed of Pan and Tilt would be.

Select OFF: No matter how the lens ratio changes, the speed of Pan and Tilt is set to the fastest.

SET NORTH:

Select ON to open this function.

Turn the camera to the north, and then save it by call preset 1.

SYSTEM INFO:

CAMERA ID: Modify in the menu of "INTERFACE SET".

BAUD RATE: Modify in the menu of "INTERFACE SET".

SDI VIDEO: Modify in the menu of "INTERFACE SET".

SV (VERSION): The version of the software.

SYSTEM RESET:

To save the changes have been made and make the changes activated.

EXIT: Push the joystick to the right to exit this level menu.

OSD

| |
|------------------|
| EXPOSURE |
| WHITE BALANCE |
| PICTURE |
| LENS PARAMETERS |
| >SYATEM SETUP |
| FUNCTION SETTING |
| SAVE AND EXIT |
| EXIT |

SYATEM SETUP

| |
|---------------------|
| FACTORY DEFAULT |
| DIRECTION INDICATOR |
| INTERFACE SET |
| TEMPERTURE READING |
| SDI VIDEO: 1080P30 |
| PAN DIRECTION |
| TILT DIRECTION |
| PROPORTIONAL PT: ON |
| SET NORTH |
| >SYSTEM INFO |
| SYSTEM RESET |
| EXIT |

| |
|------------------------|
| CAMERA ID: 001 |
| BAUD RATE: 9600 |
| SDI VIDEO: 1080P30 |
| SV801080136020AA007719 |

FUNCTION SETTING Menu

The FUNCTION SETTING menu is used to set the items related to the camera functionalities.

Note: The number of available presets may be limited by the head-ins, controllers, and DVRs that are connected to your dome system.

PRESETS SETUP:

Preset is to store the PTZ information (such as: Pan and Tilt positions, focal length etc.) under the specific condition, and call the camera PTZ quickly to shoot to the specified location that you want the camera to move to.

Note: Presets not only save desired image positions, various picture settings such as brightness, exposure values and other variables are also saved and stored.

The menu is used to manage the presets. Total of 220 presets can be managed.

PRESETS NUMBER:

The current preset number that you are managing.

PRESET MEMORY:

This feature allows you to save the image parameter to PRESET memory, turn it on to save most image parameters such as picture, white balance, exposure, focus mode etc. when you call the preset.

SET NEW PRESET:

To set up the preset of the above preset number.

1. Push the joystick to the right to enter this setting menu, you will see "call preset 1 to end".
2. Adjust the camera to the position that you want the camera to be, and then call the preset 1 using the keyboard to save the position to be the current preset.

OSD

| |
|-------------------|
| EXPOSURE |
| WHITE BALANCE |
| PICTURE |
| LENS PARAMETERS |
| SYATEM SETUP |
| >FUNCTION SETTING |
| SAVE AND EXIT |
| EXIT |

FUNCTION SETTING

| |
|------------------|
| PRESET SETUP |
| TOUR SETUP |
| PATTERN SETUP |
| IDLE TIMER: 03 |
| IDLE ACTION: OFF |
| EXIT |

3. Finished.

DELETE PRESET:

Delete the above preset.

1. Push the joystick to the right to delete this preset.

2. Finished.

EXIT: Push the joystick to the right to exit this level menu.

There are pre-programmed functionalities of the camera have been setup with presets, means that these functionalities can be activated or triggered by running certain presets or setting certain presets. For example, run preset 100 is to turn on the Rain Wiper; run preset 101 is to turn off the Rain Wiper; Run preset 95 is to turn on the OSD menu displayed on the screen, etc.

In order to use the special functions of the camera, the following presets are predefined for specific functions (You can find the default predefined preset at Web interface, Setup -> PTZ -> Advanced Settings)

Default Preset commands for SD500, EX1000 SDI version and SDI+IP version

| | | | |
|-------------------------------|--|---|-------------------------|
| Default Preset Features | Set Preset NO. | "51"#; Set left position limitation | Set Preset 51 |
| | | "52"#; Set right position limitation | Set Preset 52 |
| | | "54"#; Camera Reset (Power Cycle) | Set Preset 54 |
| | | "55"#; Turn off Back Light Compansation | Set Preset 55 |
| | | "56"#; Turn off Auto Shutter | Set Preset 56 |
| | | "57"#; Turn off Zoom times and position On Screen Display | Set Preset 57 |
| | | "58"#; Turn off Digital Zoom | Set Preset 58 |
| | | "59"#; Turn off WDR | Set Preset 59 |
| | | "60"#; Manual Iris | Set Preset 60 |
| | | "61"#; Manual white balance | Set Preset 61 |
| | | "63"#; Flip, Pendant mount | Set Preset 63 |
| | | "64"#; Black and white mode | Set Preset 64 |
| | | "99"#; Manual Focus | Set Preset 99 |
| | | Run Preset No. | "51"#; Run pan movement |
| | "52"#; Stop pan movement | | Run Preset 52 |
| | "53"#; Run cruise No. 1 | | Run Presett 53 |
| | "55"#; Turn on Back Light Compansation | | Run Preset 55 |
| | "56"#; Turn on Auto Shutter | | Run Preset 56 |
| | "57"#; Turn on Zoom times and position On Screen Display | | Run Preset 57 |
| | "58"#; Turn on Digital Zoom | | Run Preset 58 |
| | "59"#; Turn on WDR | | Run Preset 59 |
| | "60"#; Auto Iris | | Run Preset 60 |
| | "61"#; Auto white balance | | Run Preset 61 |
| | "63"#; Up Right mount | | Run Preset 63 |
| | "64"#; Color Mode | | Run Preset 64 |
| | "65"#; Auto Day/Night Mode | | Run Preset 65 |
| | "95"#; Turn on OSD menu, Press again to turn off | | Run Preset 95 |
| | "97"#; Run Patrol No.1 | | Run Preset 97 |
| | "99"#; Auto focus | | Run Preset 99 |
| | "100"#; Turn on Rain Wiper | Run Preset 100 | |
| "101"#; Turn off Rain Wiper | Run Preset 101 | | |
| "200"#; Turn on Light Sensor | Run Preset 200 | | |
| "201"#; Turn off Light Sensor | Run Preset 201 | | |

TOUR SETUP:

The menu is used to manage the tours. Total of 4 tours can be managed.

SEQUENCE NUMBER:

The current tour number that you are managing.

DEFAULT DWELL:

Set the interval time between each of presets in the above tour, the value can be selected from 3 to 255 sec.

EDIT SEQUENCE:

Set up the above tour.

1. In the order of ① ② ③ ... ⑥, add each of preset and default dwell time to the tour.
2. The tour path will be set based on the presets and default dwell have been set in step one.

| Preset Number | DEFAULT DWELL | Preset Number | DEFAULT DWELL | Preset Number | DEFAULT DWELL |
|---------------|---------------|---------------|---------------|---------------|---------------|
| ① 000 | 000 | ② 000 | 000 | ③ 000 | 000 |
| ④ 000 | 000 | ⑤ 000 | 000 | ⑥ 000 | 000 |
| 000 | 000 | 000 | 000 | 000 | 000 |
| 000 | 000 | 000 | 000 | 000 | 000 |
| ... | ... | ... | ... | ... | ... |

RUN CONTINOUSELY: start the tour has been set.

EXIT: Push the joystick to the right to exit this level menu.

PATTERN SETUP:

A pattern is a memorized, repeating series of pan, tilt, zoom, and preset functions that can be recalled with a command from a controller or automatically by a programmed function (alarm, park, event, or power-up).

The menu is used to manage the patterns. Total of 4 patterns can be managed.

PATTERN NUMBER:

The current pattern number that you are managing.

RECORD NEW PATTERN:

Set up the above pattern.

1. Push the joystick to the right to enter this setting menu.
2. Move the camera to the start position you want, and then call the preset 1 to save.
3. Move the camera to each position you want to record the pattern, and then call the preset1 to end.
4. Finished.

RUN CONTINIUSELY: start the above pattern.

EXIT: Push the joystick to the right to exit this level menu.

IDLE TIMER:

If the camera stays in No-operation for certain amount of IDLE Time, the camera would take action automatically.

The menu is used to set the IDLE time, and value can be selected from 0 to 255 sec.

IDLE ACTION:

After the IDLE time, the camera starts the IDLE action automatically.

Even if the idle time's value is set to 0, or during the IDLE time, manual operation will always have the priority to the response.

The menu is used to select the IDLE action.

The IDLE action can be selected from: OFF, PAIT-4, PAIT-3, PAIT-2, PAIT-1, TOUR-4, TOUR-3, TOUR-2, TOUR-1, PRESET1-220.

EXIT: Push the joystick to the right to exit this level menu.

Firmware Upgrade

There are 2 types of firmware with this camera can be upgradable. The latest camera firmware is available to be downloaded from Bolin website: www.bolintechnology.com.

1. IP encoder firmware upgrade via IP network
2. MCU (Micro Control Unit) firmware upgrade via IP network

NOTE:

The firmware upgrade process is intended to be performed under the supervision of a BOLIN-Authorized repair technician. For assistance with this, please contact your authorized BOLIN Technology dealer, installer, or integrator. BOLIN Technology Technical Support can also be reached for assistance with this process

Upgrading IP encoder firmware

You can upgrade camera IP encoder module Firmware via IP network. Connect and configure your camera with your local network successfully, log in the camera IP web interface, go to System, Maintenance section to upgrade the firmware. How to make Firmware upgrade for IP Encoder, please refer to User Manual Part Two.

Upgrading MCU (Micro Control Unit) Firmware

Same way as how IP encoder firmware can be upgraded, you can upgrade MCU firmware to the camera via IP network. Follow the steps with IP web interface prompt processes to finish the upgrade. How to make Firmware upgrade for MCU, please refer to User Manual Part Two.

Use IP Video Output

To use IP video output, please refer to **PART TWO - NETWORK CAMERA USER MANUAL**

Setting Camera over the LAN

To view and configure your camera via the local area network (LAN), you need to install the Controls (VideoPlugin) for the first time to login the camera IP interface.

1. Connect your camera and your PC as shown in the figure below to ensure the routing is available.
2. Modify the camera settings if necessary, including its IP address and subnet mask.

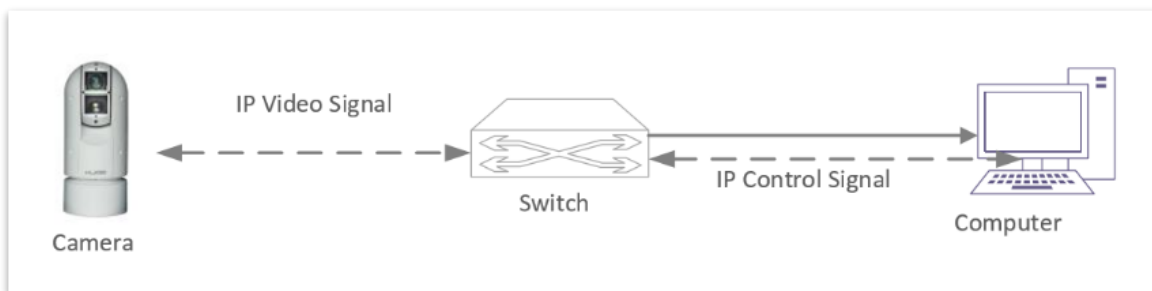

NOTE!

- Default IP address is "192.168.0.13", default username is "admin", and default password is "admin".

Accessing your camera

Before you begin, please check:

1. Make sure the self-test is completed.
2. Your camera is operating properly and connected to the network.
3. The PC client you are using is installed with Internet Explorer 11.
4. Open Internet Explorer on your PC.
5. In the address bar, input the IP address plus the port number of your camera (default IP is 192.168.0.13, so the login URL should be <http://192.168.0.13:8080>), then press Enter to open the login page.
6. Enter the username (default is "admin") and password (default is "admin")
7. Click Login button to access to IP video interface.

To use IP video output, please refer to **PART TWO - NETWORK CAMERA USER MANUAL**

Menu Configuration

The menus of camera are configured as described below.

OSD Menu Configuration

| Menu | EXPOSURE | MODE | FULL AUTO | IRIS | Null |
|------|----------|------|------------|--------------------|--|
| | | | | GAIN | Null |
| | | | | SHUTTER | Null |
| | | | | BRIGHT | Null |
| | | | | BACKLIGHT MODE | OFF, ON |
| | | | | DEFOG | OFF, ON |
| | | | | EX-COMP MODE | ON, OFF |
| | | | | EX-COMP LEVEL | -10.5dB, -9dB, -7.5dB, -6dB, -4.5dB, -3dB, -1.5dB, 0dB, 1.5dB, 3dB, 4.5dB, 7dB, 9.5dB, 10dB |
| | | | | HIGH SENSITIVITY | OFF, ON |
| | | | | SLOW AE | 1 to 48 |
| | | | | SLOW SHUTTER | OFF, ON |
| | | | | GAIN LIMIT | 10.7dB, 14.3dB, 17.8dB, 21.4dB, 25.0dB, 28.6dB, 32.1dB, 35.7dB, 39.3dB, 42.8dB, 46.4dB, 50dB |
| | | | | MIN. SHUTTER MODE | OFF, ON |
| | | | | MIN. SHUTTER LIMIT | 1/1, 1/2, 1/4, 1/8, 1/15, 1/30, 1/60, 1/90, 1/100, 1/125, 1/180, 1/250, 1/350, 1/500, 1/725, 1/1K, 1/1.5K, 1/2K, 1/3K, 1/4K, 1/6K, 1/10K |
| | | | | EXIT | |
| | | | MANUAL | IRIS | CLOSE, F1.6, F2.0, F2.4, F2.8, F3.4, F4, F4.8, F5.6, F6.8, F8, F9.6, F11, F14 |
| | | | | GAIN | 0dB, 3.6dB, 7.1dB, 10.7dB, 14.3dB, 17.8dB, 21.4dB, 25dB, 28.6dB, 32.1dB, 35.7dB, 39.3dB, 42.8dB, 46.4dB, 50dB |
| | | | | SHUTTER | 1/1, 1/2, 1/4, 1/8, 1/15, 1/30, 1/60, 1/90, 1/100, 1/125, 1/180, 1/250, 1/350, 1/500, 1/725, 1/1K, 1/1.5K, 1/2K, 1/3K, 1/4K, 1/6K, 1/10K |
| | | | | BRIGHT | Null |
| | | | | BACKLIGHT MODE | Null |
| | | | | DEFOG | Null |
| | | | | EX-COMP MODE | Null |
| | | | | EX-COMP LEVEL | Null |
| | | | | HIGH SENSITIVITY | OFF, ON |
| | | | | SLOW AE | Null |
| | | | | SLOW SHUTTER | OFF, ON |
| | | | | GAIN LIMIT | 10.7dB, 14.3dB, 17.8dB, 21.4dB, 25.0dB, 28.6dB, 32.1dB, 35.7dB, 39.3dB, 42.8dB, 46.4dB, 50dB |
| | | | | MIN. SHUTTER MODE | Null |
| | | | | MIN. SHUTTER LIMIT | Null |
| | | | | EXIT | |
| | | | IRIS PRIOR | IRIS | CLOSE, F1.6, F2.0, F2.4, F2.8, F3.4, F4, F4.8, F5.6, F6.8, F8, F9.6, F11, F14 |
| | | | | GAIN | Null |
| | | | | SHUTTER | Null |
| | | | | BRIGHT | Null |
| | | | | BACKLIGHT MODE | Null |
| | | | | DEFOG | Null |
| | | | | EX-COMP MODE | ON, OFF |
| | | | | EX-COMP LEVEL | -10.5dB, -9dB, -7.5dB, -6dB, -4.5dB, -3dB, -1.5dB, 0dB, 1.5dB, 3dB, 4.5dB, 7dB, 9.5dB, 10dB |
| | | | | HIGH SENSITIVITY | OFF, ON |
| | | | | SLOW AE | Null |
| | | | | SLOW SHUTTER | OFF, ON |
| | | | | GAIN LIMIT | 10.7dB, 14.3dB, 17.8dB, 21.4dB, 25.0dB, 28.6dB, 32.1dB, 35.7dB, 39.3dB, 42.8dB, 46.4dB, 50dB |
| | | | | MIN. SHUTTER MODE | Null |
| | | | | MIN. SHUTTER LIMIT | Null |
| | | | | EXIT | |

| | | | | |
|--------------------|--|--------------------|-------------------|--|
| | | SHUTTER | IRIS | Null |
| | | | GAIN | Null |
| | | | SHUTTER | 1/1, 1/2, 1/4, 1/8, 1/15, 1/30, 1/60, 1/90, 1/100, 1/125, 1/180, 1/250, 1/350, 1/500, 1/725, 1/1K, 1/1.5K, 1/2K, 1/3K, 1/4K, 1/6K, 1/10K |
| | | | BRIGHT | Null |
| | | | BACKLIGHT MODE | Null |
| | | | DEFOG | Null |
| | | | EX-COMP MODE | ON, OFF |
| | | | EX-COMP LEVEL | -10.5dB, -9dB, -7.5dB, -6dB, -4.5dB, -3dB, -1.5dB, 0dB, 1.5dB, 3dB, 4.5dB, 7dB, 9.5dB, 10dB |
| | | | HIGH SENSITIVITY | OFF, ON |
| | | | SLOW AE | Null |
| | | | SLOW SHUTTER | OFF, ON |
| | | | GAIN LIMIT | 10.7dB, 14.3dB, 17.8dB, 21.4dB, 25.0dB, 28.6dB, 32.1dB, 35.7dB, 39.3dB, 42.8dB, 46.4dB, 50dB |
| | | | MIN. SHUTTER MODE | Null |
| | | MIN. SHUTTER LIMIT | Null | |
| | | EXIT | | |
| | | BRIGHT | IRIS | Null |
| | | | GAIN | Null |
| | | | SHUTTER | Null |
| | | | BRIGHT | 0 to 31 |
| | | | BACKLIGHT MODE | Null |
| | | | DEFOG | Null |
| EX-COMP MODE | ON, OFF | | | |
| EX-COMP LEVEL | -10.5dB, -9dB, -7.5dB, -6dB, -4.5dB, -3dB, -1.5dB, 0dB, 1.5dB, 3dB, 4.5dB, 7dB, 9.5dB, 10dB | | | |
| HIGH SENSITIVITY | OFF, ON | | | |
| SLOW AE | Null | | | |
| SLOW SHUTTER | OFF, ON | | | |
| GAIN LIMIT | 10.7dB, 14.3dB, 17.8dB, 21.4dB, 25.0dB, 28.6dB, 32.1dB, 35.7dB, 39.3dB, 42.8dB, 46.4dB, 50dB | | | |
| MIN. SHUTTER MODE | Null | | | |
| MIN. SHUTTER LIMIT | Null | | | |
| EXIT | | | | |
| WHITE BALANCE | MODE | ATW | USER DEFINED | R: Null |
| | | | USER DEFINED | B: Null |
| | | | EXIT | |
| | | OUTDOOR | USER DEFINED | R: Null |
| | | | USER DEFINED | B: Null |
| | | | EXIT | |
| | | INDOOR | USER DEFINED | R: Null |
| | | | USER DEFINED | B: Null |
| | | | EXIT | |
| | | AUTO | USER DEFINED | R: Null |
| | | | USER DEFINED | B: Null |
| | | | EXIT | |
| | | SVL OUTDOOR AUTO | USER DEFINED | R: Null |
| | | | USER DEFINED | B: Null |
| | | | EXIT | |
| | | SVL | USER DEFINED | R: Null |
| | | | USER DEFINED | B: Null |
| | | | EXIT | |
| | | SVL AUTO | USER DEFINED | R: Null |
| | | | USER DEFINED | B: Null |
| | | | EXIT | |
| | | OUTDOOR AUTO | USER DEFINED | R: Null |
| | | | USER DEFINED | B: Null |
| | | | EXIT | |
| | | USER | USER DEFINED | R: 0 to 255 |
| | | | USER DEFINED | B: 0 to 255 |
| | | | EXIT | |
| OPW | USER DEFINED | R: Null | | |
| | USER DEFINED | B: Null | | |
| | EXIT | | | |

| | | | |
|------------------|---------------------|---|------------|
| PICTURE | SHARPNESS | 0 to 15 | |
| | EFFECT | OFF, B&W, NEG.ART | |
| | COLOR GAIN | 0 to 14 | |
| | COLOR HUE | 0 to 14 | |
| | FLIP | OFF, ON | |
| | MIRROR | OFF, ON | |
| | NOISE REDUCTION | | |
| | Mode | OFF, 2D/3D, 5, 4, 3, 2, 1 | |
| | 2D | OFF, 5, 4, 3, 2, 1 | |
| | 3D | OFF, 5, 4, 3, 2, 1 | |
| | EXIT | | |
| | STABILIZER | OFF, ON | |
| | STABLE ZOOM | OFF, ON | |
| | GAMMA | 0, 1 | |
| | GAMMA OFFSET | -49 to -64, 0 to 64 | |
| | LOW-ILLUM. CHROMA | OFF, 3, 2, 1 | |
| | DE-FLICKER | OFF, ON | |
| | WDR | OFF, ON, VE ON | |
| | HLC LEVEL | OFF, HIGH, MID, LOW | |
| | HLC MASK LEVEL | OFF, HIGH, MID, LOW | |
| | AUDIO MUTE | OFF, ON | |
| | EXIT | | |
| | LENS PARAMETERS | ZOOM | |
| | | DIGITAL ZOOM | OFF, ON |
| | | ZOOM OSD DISPLAY | OFF, ON |
| EXIT | | | |
| AUTO FOCUS | | | |
| AF SENSITIVITY | | NORMAL, LOW | |
| AF MODE | | NORMAL AF, ZOOM TRIGGER, INTERVAL AF | |
| EXIT | | | |
| MANUAL FOCUS | | | |
| MF SPEED | | FIXED SPEED, VARIABLE SPEED, | |
| VARIABLE SPEED | | (Adjustable when MF SPEED set to VARIABLE SPEED MODE) | |
| EXIT | | | |
| NEAR LIMIT | | 11cm, 30cm, 0.8m, 1.2m, 1.4m, 1.65m, 2m, 2.5m, 3.1m, 4.2m, 6m, 10m, 20m, OVER | |
| JOYSTICK RECOVER | | NONE, AF-AI, A/I, A/F | |
| A/F RECOVER TIME | | 0 to 255 | |
| A/I RECOVER TIME | | 0 to 255 | |
| DAY/NITE MODE | | AUTO, DAY, NITE | |
| LASER SETUP | | ON, OFF | |
| ZOOMING SPEED | | 1 to 8 | |
| PRESET SPEED | | 1 to 255 | |
| EXIT | | | |
| SYSTEM SETUP | | FACTORYDEFAULT | Succeed |
| | | DIRECTION INDICATOR | OFF, ON |
| | | INTERFACE SET | |
| | | CAMERA ID | 001 to 255 |
| | BAUD RATE | 2400, 4800, 9600, 19200 | |
| | FACTORY FORMAT | Succeed | |
| | LOW LATENCY | ON, OFF | |
| | EXIT | | |
| | TEMPERATURE READING | OFF, ON | |
| | SDI VIDEO | 1080p @60@59.94@50@30@29.97@25 1080i @60@59.94@50, 720p @60@59.94@50@30@25 | |
| | PAN DIRECTION | NORMAL, INVERT | |
| | TILT DIRECTION | NORMAL, INVERT | |
| | PROPORTIONAL PT | ON, OFF | |
| | SET NORTH | MOVE TO NORTH DIR CALL PRESET 1 TO END | |
| | SYSTEM INFO | | |
| | CAMERA ID | 001 | |
| | BAUD RATE | 9600 | |
| | SDI VIDEO | 1080p30 | |
| | SV | SVB0I080136020AA007T19 | |
| | SYSTEM RESET | | |
| | EXIT | | |

| | | |
|------------------|--------------------|--|
| FUNCTION SETTING | PRESETS SETUP | |
| | PRESET NUMBER | 001 to 220 |
| | PRESET MEMORY | ON, OFF |
| | SET NEW PRESET | CALL PRESET 1 TO END |
| | DELETE PRESET | |
| | EXIT | |
| | TOUR SETUP | |
| | SEQUENCE NUMBER | 001 to 004 |
| | DEFAULT DWELL | 003 to 255 |
| | EDIT SEQUENCE | 000-000, SAVE & EXIT, CANCEL |
| | RUN CONTINUOUSLY | |
| | EXIT | |
| | PATTERN SETUP | |
| | PATTERN NUMBER | 001 to 004 |
| | RECORD NEW PATTERN | MOVE TO START POINT CALL PRESET 1 TO END |
| | RUN CONTINUOUSLY | |
| | EXIT | |
| | IDLE TIMER | 000 to 255 |
| | IDLE ACTION | OFF, PAIT-4, PAIT-3, PAIT-2, PAIT-1, TOUR-4, TOUR-3, TOUR-2, TOUR-1, PRE001 to PRE220, |
| | EXIT | |
| | SAVE AND EXIT | |
| | EXIT | |

Dimensions

Unit: mm

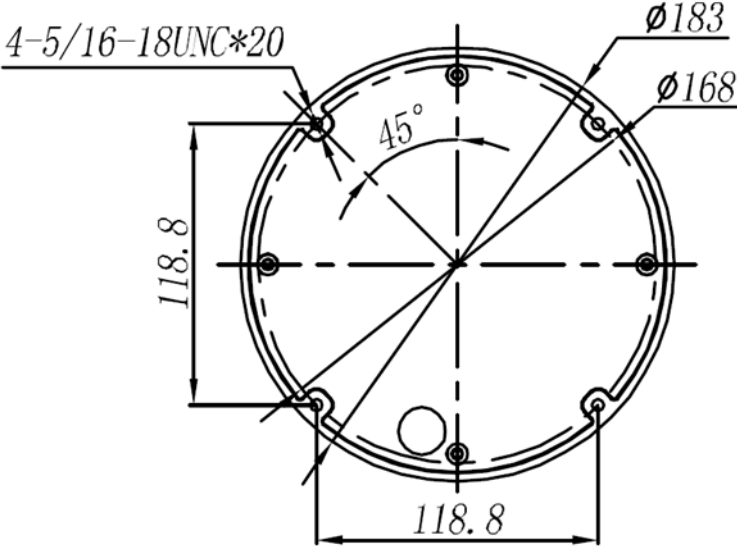
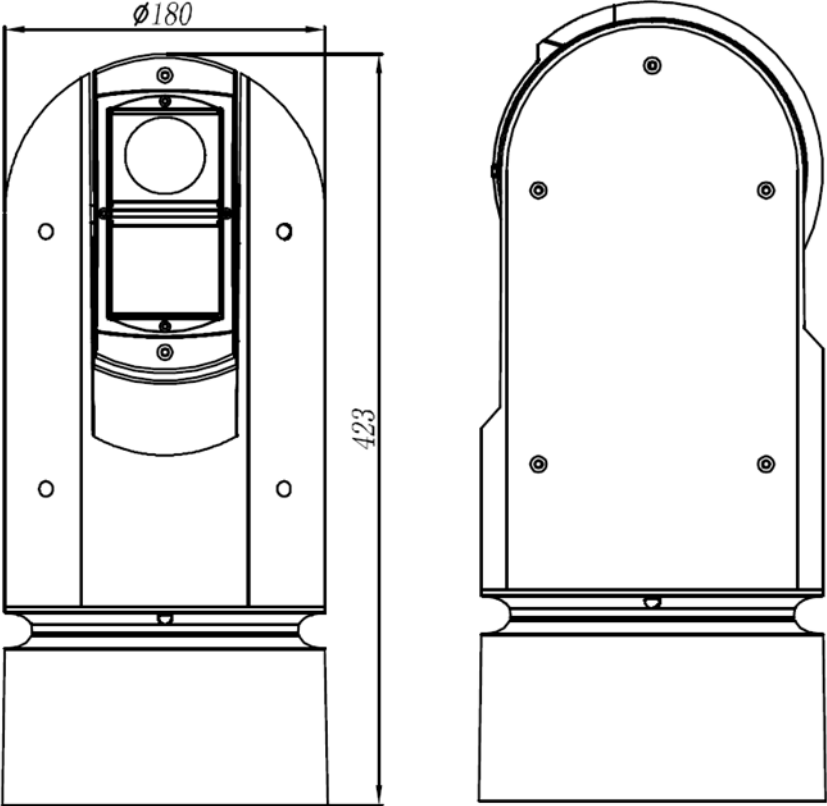



www.bolintechnology.com

2082 TECHNOLOGY LLC
dba
BOLIN TECHNOLOGY