

KBD-1010

Universal PTZ Camera Remote Controller

USER MANUAL

VERSION: KBD-M-02202021

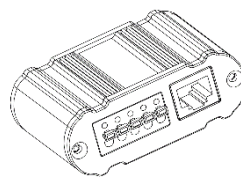
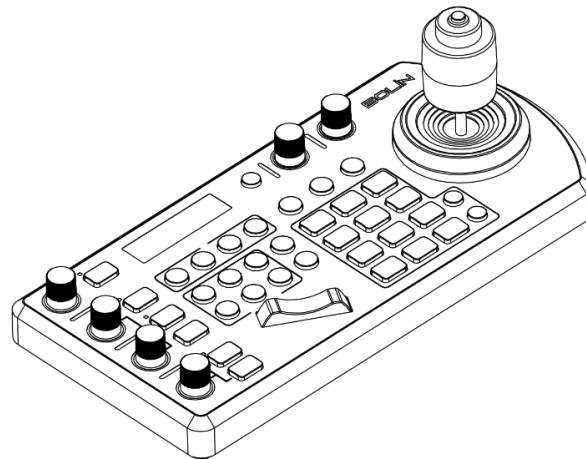

KBD-1010-RNV

© 2021 Bolin Technology

Contents

IMPORTANT INFORMATION	4
WHAT'S IN THE BOX	6
OVER VIEW	7
KEY FEATURES:.....	7
KEYBOARD DIAGRAMS	8
KBD-1010	8
KEYBOARD	9
LED SCREEN DISPLAY	10
JUNCTION BOX.....	11
SYSTEM OVERVIEW	12
CROSS-PROTOCOL MIX CONTROL (PTZ CONTROLLER MODE)	12
CONNECTION.....	13
POWER.....	13
CONNECTOR PINOUT DEFINITION	14
IP CONNECTION.....	15
MAKE SERIAL PORT CONNECTION	15
RS232 CONNECTION.....	16
RS422 CONNECTION.....	18
RS485 CONNECTION.....	23
IP CONTROL	26
Use ONVIF IP Control:.....	26
Use VISCA OVER IP Control:.....	26
CROSS-PROTOCOL MIX CONTROL	27
.....	27
TALLY LIGHT GPI I/O CONNECTION.....	27
HOW TO MAKE THE CONNECTION WITH BOLIN PRODUCTS	30
.....	30
CONTROL MODE - VIDEO ROUTER SWITCH.....	31
CROSS-PROTOCOL MIX CONTROL (VIDEO ROUTER SWITCH MODE)	31
IP NETWORK CONNECTION.....	33
LOGIN PREPARATION	33
LOGGING IN TO THE WEB INTERFACE	33
INTRODUCTION TO THE WEB INTERFACE.....	33
CONFIGURATION FILE EXPORT & IMPORT	34
KEYBOARD SETTING TOOL	35
KEYBOARD CONFIGURATION.....	38
<i>Interacting with the KBD-1010.....</i>	<i>38</i>
SETUP:	38
<i>Setup button.....</i>	<i>38</i>
IP SETUP.....	38
BUTTON LIGHT.....	39
ASSIGN KEYS	39
HOW TO USE ASSIGN KEYS TO OPERATE THE TRACE MEMORY FUNCTION.....	40
1. ASSIGN TRACE MEMORY FUNCTION TO THE ASSIGN KEY	40
FACTORY DEFAULT.....	41
TALLY - GPI I/O	41
PASSWORD SETTING.....	42
JOYSTICK ZOOM SETTING	42
MODEL INFO	43
VISCA OVER IP	43
CONTROL MODE	44

HOW TO ASSIGN CAMERA	44
MANUALLY ADDING CAMERAS	44
ADDING AN ONVIF CAMERA TO KEYBOARD	45
<i>Adding manually from Local Area Network (LAN).....</i>	<i>45</i>
<i>Scanning Local Area Network (LAN) for available ONVIF cameras</i>	<i>45</i>
<i>Adding ONVIF cameras to be controlled via WAN</i>	<i>46</i>
ADDING A VISCA OVER IP CAMERA TO KEYBOARD	47
<i>Adding manually from Local Area Network (LAN).....</i>	<i>47</i>
<i>Scanning local network for available VISCA over IP cameras.....</i>	<i>48</i>
<i>Adding VISCA over IP cameras to be controlled via WAN</i>	<i>48</i>
INTERACTING WITH CAMERAS.....	50
DUAL RS422 BUTTON A/B	50
OPTIONS FOR CALLING CAMERA	50
CONTROLLING A CAMERA	50
<i>Engaging the Camera OSD Menu for non-IP cameras.....</i>	<i>50</i>
<i>Engaging the Camera OSD Menu for PELCO-D or ONVIF-IP Cameras.....</i>	<i>51</i>
MANUAL MOVEMENTS.....	51
SETTING AND CALLING PRESETS.....	51
<i>Setting / creating presets:</i>	<i>52</i>
<i>Calling presets:</i>	<i>52</i>
<i>Resetting / Clearing presets:</i>	<i>52</i>
ADJUSTING IMAGE PARAMETERS	52
FIRMWARE UPGRADE	54
<i>Keyboard MCU firmware upgrade.</i>	<i>54</i>
<i>Keyboard IP firmware upgrade.</i>	<i>54</i>
LCD SCREEN SETTING TREE	55
DIMENSIONS	56

Operating Instructions

Thank you for purchasing our product. If there are any questions, please contact the authorized dealer.

Before operating the unit, please read this manual thoroughly and retain it for future reference.

Copyright

Copyright 2018 Bolin Technology all rights reserved. No part of this manual may be copied, reproduced, translated, or distributed in any form or by any means without prior consent in writing from our company.

Trademark Acknowledgement

 and other Bolin's trademarks and logos are the property of Bolin Technology Other trademarks, company names and product names contained in this manual are the property of their respective owners.

IMPORTANT INFORMATION

Legal Notice

Attention:

To ensure account security, please change the password after your first login. You are recommended to set a strong password (no less than eight characters). Password login does not apply to some models that do not need password login.

The contents of this document are subject to change without prior notice. Updates will be added to the new version of this manual. We will readily improve or update the products or procedures described in the manual.

Best effort has been made to verify the integrity and correctness of the contents in this document, but no statement, information, or recommendation in this manual shall constitute formal guarantee of any kind, expressed or implied. We shall not be held responsible for any technical or typographical errors in this manual.

The product appearance shown in this manual is for reference only and may be different from the actual appearance of your device.



This manual is a guide for multiple product models and so it is not intended for any specific product.

In this manual, the illustrations of displayed interface, parameters displayed, drawings and value ranges may vary with models. Please see the actual product for details.

Due to uncertainties such as physical environment, discrepancy may exist between the actual values and reference values provided in this manual.

Use of this document and the subsequent results shall be entirely on the user's own responsibility.

Symbols

Symbol	Description
 WARNING!	Contains important safety instructions and indicates situations that may cause bodily injury.
 CAUTION!	User must be careful and improper operations may cause damage or malfunction of product.
 NOTE!	Indicates useful or supplemental information about the use of product.

Safety Information



WARNING!

Installation and removal of the unit and its accessories must be carried out by qualified personnel. You must read all of the Safety Instructions supplied with your equipment before installation and operation.

Warnings:

- If the product does not work properly, please contact your dealer. Never attempt to disassemble the unit yourself. (We will not assume any responsibility for problems caused by unauthorized repair or maintenance.)
- This installation should be made by a qualified service person and should conform to all the local codes.
- When shipping, the unit should be packed in its original packaging.
- Make sure the power supply voltage is correct before connecting to the unit.
- Do not drop or subject the unit to physical shock.

Maintenance Precautions:

- Ensure that no moisture or liquid comes into contact with any surface of the keyboard, as liquid may damage the functions of the keyboard.
- Keep dust the RJ-45 ports free from dust and moisture
- Only use the original, uncut (not spliced) power supply that is included with the keyboard

Regulatory Compliance

FCC Part 15

This equipment has been tested and found to comply with the limits for digital device, pursuant to part 15 of the FCC Rules. These limits are designed to provide reasonable protection against harmful interference when the equipment is operated in a commercial environment. This equipment generates, uses, and can radiate radio frequency energy and, if not installed and used in accordance with the instruction manual, may cause harmful interference to radio communications. Operation of this equipment in a residential area is likely to cause harmful interference in which case the user will be required to correct the interference at his own expense.

This product complies with Part 15 of the FCC Rules. Operation is subject to the following two conditions:

This device may not cause harmful interference.

This device must accept any interference received, including interference that may cause undesired operation.



LVD/EMC Directive

This product complies with the European Low Voltage Directive 2006/95/EC and EMC Directive 2004/108/EC.











WEEE Directive—2002/96/EC

The product this manual refers to is covered by the Waste Electrical & Electronic Equipment (WEEE) Directive and must be disposed of in a responsible manner.

WHAT'S IN THE BOX

Standard Accessories

	Keyboard
	Power supply and power cord
	RJ-45 to Phoenix Breakout
	RJ-45 Coupler
	Junction box
	RJ45 Control Cable
	Tally light Terminal Contact
	Assign Keys label sheet
	User Manual/Welcome Card

Optional Accessories

	RS232 8 Pin Mini Din to Phoenix Terminal Block
---	--

When the "Optional" Accessories will be needed:

- When a 8 Pin Mini Din RS232 connector camera needs to be connected to and controlled.

Over View

This user guide is suitable for the following models:

- KBD-1010-RNV (IP camera controller with serial port and ONVIF IP and VISCA Over IP protocol)

Key Features:

- Cross protocol mix-control with RS232/RS422 and IP
- Protocol support: VISCA, PELCO D/P, ONVIF IP, VISCA over IP, CGI*
- Quick Access Control
- High-quality sync-6-way joystick control
- Video router camera monitor switching with PTZ control.
- Independent wide range dual power input: 6-48VDC, POE

Functionalities:

- Easy, ergonomic PTZ control of multiple remote cameras for live event production and content creation. Applications: Education, Broadcast, Video Conferencing, House of Worship etc.
- This compact remote controller features a high-quality joystick that allows effortless one-handed pan, tilt and zoom adjustments. Zoom can also be controlled via the joystick or a supplementary seesaw lever; dedicated knobs and control buttons simplify direct access to frequently-needed camera functions without needing to use the camera menus.
- Quick Access features include the control of Exposure, Shutter Speed, Iris, Compensation, White Balance, Focus, PT Speed, Zoom Speed.
- The controller supports serial RS232/RS422 and IP mix-control. It allows you to use RS232/RS422/IP control on one controller to control cameras in a single system.
- With IP control, automatically search available IP cameras in the network and assign IP addresses easily. IP control supports ONVIF, CGI*, VISCA Over IP.
- Up to 256 camera presets with memory of image parameters and 8 patterns/cruises to recall camera moves. (Requires camera support)
- Tally Indicator: Includes Normal Tally/On-Air Tally/Contact Modes
- Supports 2 groups (7 cameras per group) via VISCA RS422 daisy chain control.
- Compatible with video router switch, to switch camera on the router with PTZ camera control.
- Camera exposure adjustment: Full Auto, Iris Priority, Shutter Priority, Manual Iris Gain, Manual Shutter Gain, Black Level.
- Provides PTZ camera configuration file export/import via IP interface capability to duplicate the keyboard setting to multiple keyboards.
- Unlimited number of controllers can operate on a single network to control up to 255 IP cameras. Controls up to total 255 cameras (Combine using PELCO/VISCA/ONVIF IP/VISCA-Over-IP Protocol).
- Up to 6 selectable ASSIGN function key, additional functions can be assigned to ASSIGN buttons.
- Multi-color Key/Button illumination indicator
- Full compatibility is provided with all Bolin PTZ cameras and Sony BRC, SRG series PTZ cameras and most PTZ cameras in the market that support RS232/RS422/RS485/IP control.
- Control firmware upgrade is available via USB to keep the performance of the controller up to date.
- Configuration import/export via IP
- Software Tool for bulk camera/keyboard setup.
- * Available via firmware upgrade.

Keyboard Diagrams

KBD-1010

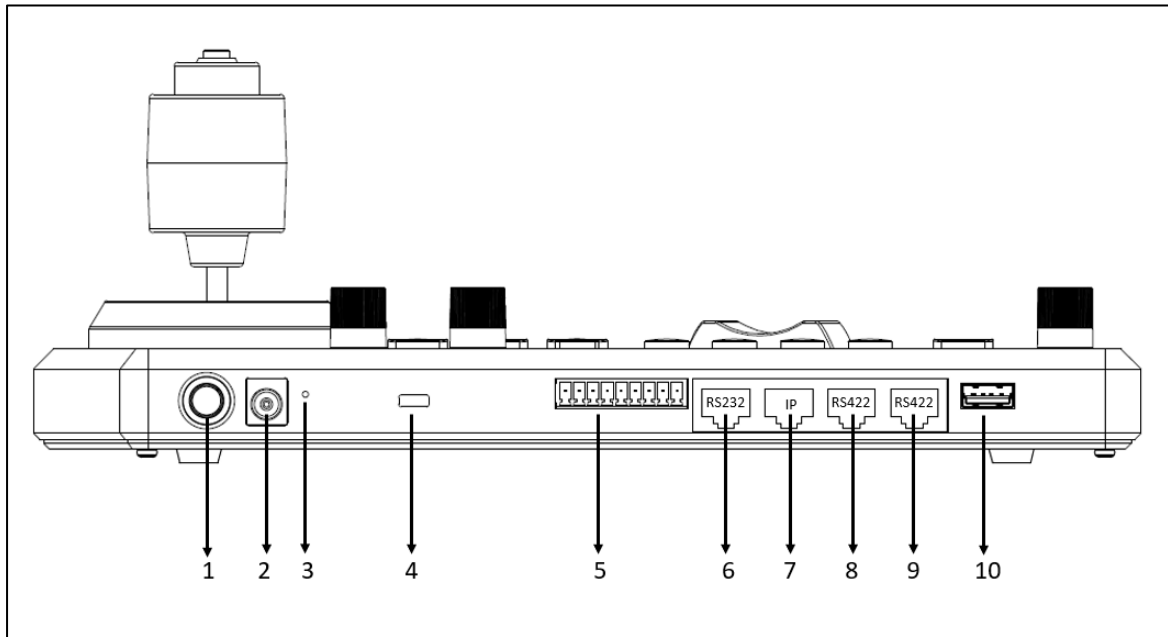

- 1. Power Button**
Power on / Power off the keyboard
- 2. 12V DC Power Port, wide range input tolerance from 5V-48VDC**
Connect the supplied DC power adaptor and cord
- 3. Reset Button**
Hard reset to make Joystick and Seesaw recalibrate accuracy
NOTE: Only used when Joystick or Seesaw have problems or experience is poor, and please do not press / touch any button during the reset process. (Use safety pin to press and hold for 3 seconds to do reset)
- 4. Kensington Security slot**
Use a lock to physically secure the keyboard in place
- 5. Tally / Contact (GPI I/O connector)**
Tally control interface
- 6. RS232 interface / RJ-45 port**
Connect RS232 adapter
- 7. IP Interface / RJ-45 port**
Connect the keyboard to a network or a PoE switch for power supply
- 8. RS422 (B) interface, use for RS485 as well / RJ-45 port**
Connect an RS422 adapter to control up to 7 daisy-chained RS422 cameras (Group A)
- 9. RS422(A) interface,**
 - a. In PTZ Controller Mode, use for RS485 as well / RJ-45 port**
Connect an RS422 adapter to control up to 7 daisy-chained RS422 cameras (Group B)
 - b. In Video Router Switch Mode, control connection interface / RJ-45 port**
Connect to video matrix, to control video switching via keyboard
- 10. Firmware Upgrade USB port**

Keyboard

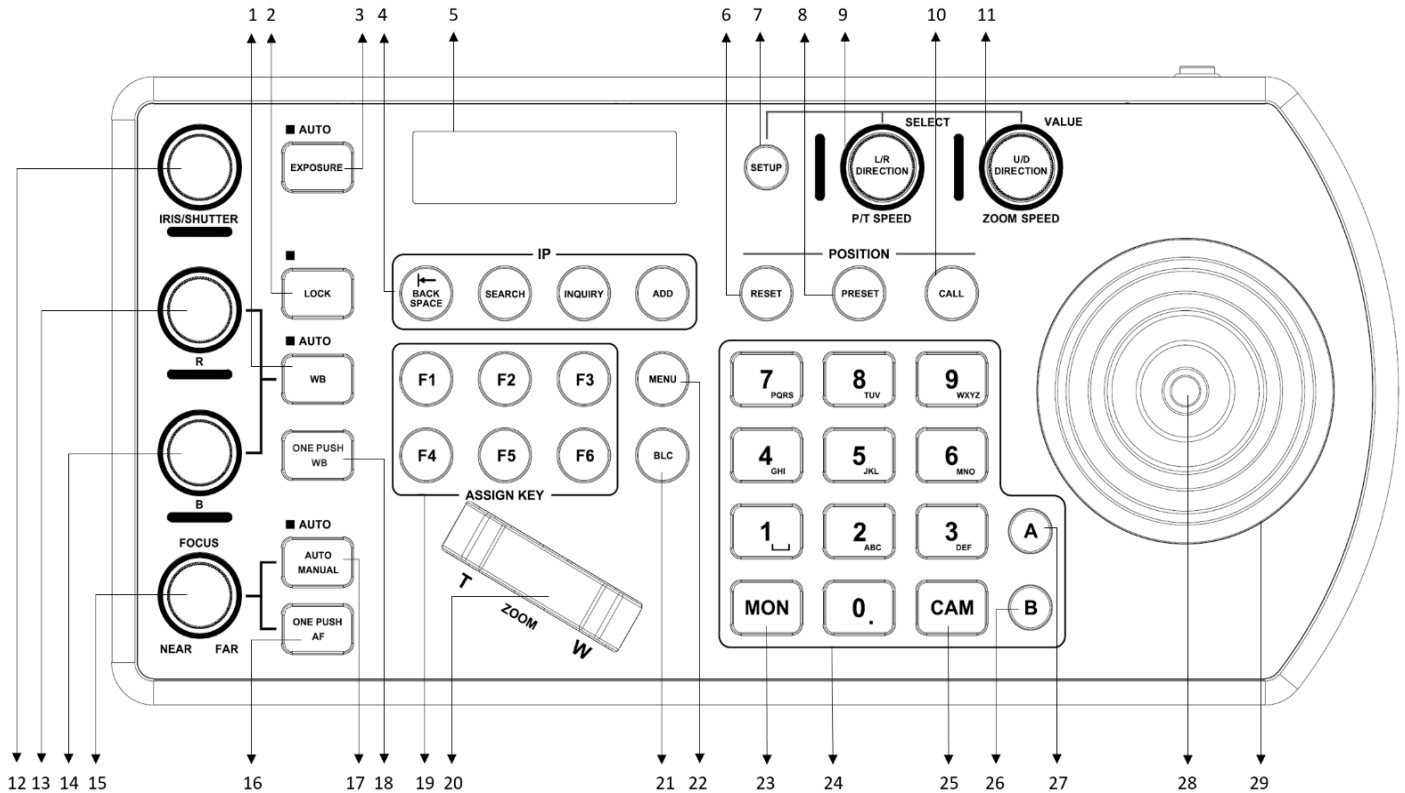

1. **White Balance, (Auto, Manual):** Press once for Auto, press again to activate manual adjustments
2. **Lock** – locks all image adjustment buttons and dials
3. **Exposure** (Full Auto, Iris Priority, Shutter Priority, Manual Iris Gain, Manual Shutter Gain, Black Level.)
4. **IP Interface Buttons** – used to interact with IP cameras
5. **LCD Screen** – Display for navigating keyboard settings
6. **Reset** – used for clearing presets
7. **Setup** – used for keyboard menu setting
8. **Preset** – used for saving camera presets
9. **Pan Tilt Speed knob**
 - **Rotate:** Speed adjustment / Navigate (in menu)
 - **Press:** Select (in menu)
 - **Long press:** Invert L/R direction
10. **Call** – used for calling camera presets
11. **Zoom Speed knob**
 - **Rotate:** Zoom speed adjustment / Adjust value (in menu)
 - **Press:** Save (in menu)
 - **Long press:** Invert U/D Direction
12. **Manual Adjustment for Exposure-** Iris Priority, Shutter Priority, Manual Iris Gain, Manual Shutter Gain, Black Level.
13. **Manual Red Adjustment for White Balance**
14. **Manual Blue Adjustment for White Balance**
15. **Manual Focus**
16. **One-Push Focus**
17. **Focus Auto/ Manual Toggle**
18. **OPW (One Push WB) For White Balance**
19. **Assign Keys** – used to assign quick access to commands
20. **Zoom Seesaw** – For zoom in / zoom out
21. **BLC (Back Light Compensation)** – Toggles Back Light Compensation setting in camera
22. **Menu** for pulling out camera OSD menu
23. **MON:** For calling monitor number
24. **Alphanumeric Keypad** – used for camera call, preset call, entering data (in menu)
25. **CAM:** For calling camera number

26. RS422 Group B Selection
27. RS422 Group A Selection
28. Enter Button for menu setting to Enter/Confirm data.
29. PTZ Joystick

LED Screen Display

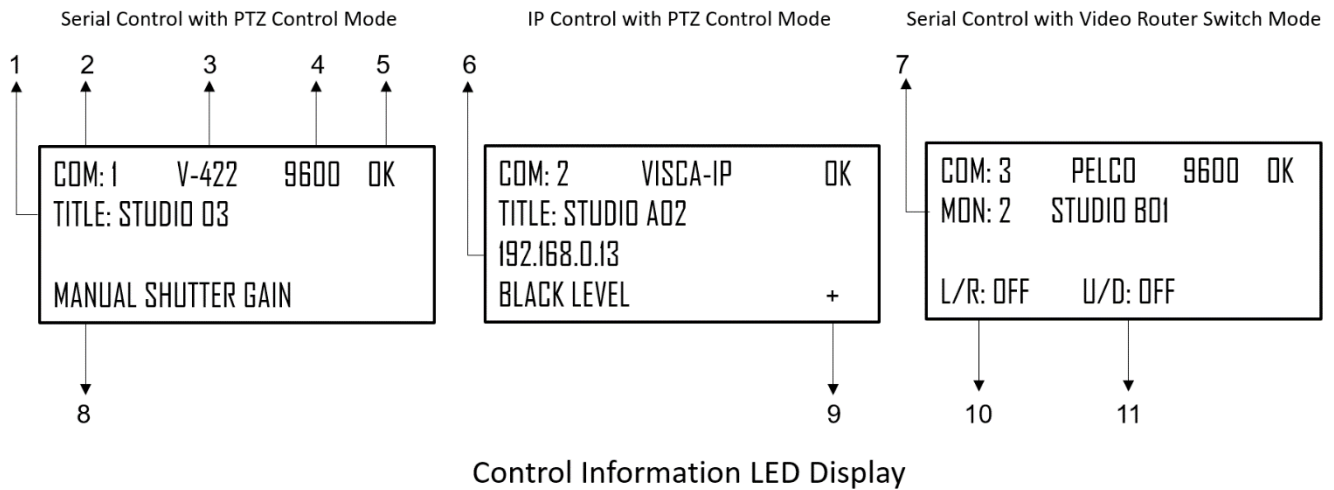

1. Camera Title, displays the title is set for the camera being controlled.
2. Camera Identifier – Camera ID, identifies which camera is being controlled, and the protocol being used
3. Protocol, the control protocol that the camera being controlled is using.
4. Baud Rate, the serial control baud rate that the camera being controlled is using.
5. Control status,
 - a. Showing OK when the connection between the camera and the keyboard is built and the communication is working properly.
 - b. Showing NO when the connection or the communication between the camera and the keyboard is not working properly.
6. IP address of the IP camera is being controller.
7. Monitor Identifier – When VIDEO ROUTER SWITCH mode is selected, identifies which monitor is being used for display the selected camera video image.
8. Exposure Control Mode, use Auto Exposure knob to select an exposure control mode among Full Auto, Iris Priority, Shutter Priority, Manual Iris Gain, Manual Shutter Gain, Black Level.
9. Network Connectivity indicator
 - a. If the “+” appears, this means that the network is successfully connected
 - b. If the “+” does not appear, this means that the network is not connected
10. Tilt Reversal Indicator
11. Pan Reversal Indicator

Junction Box

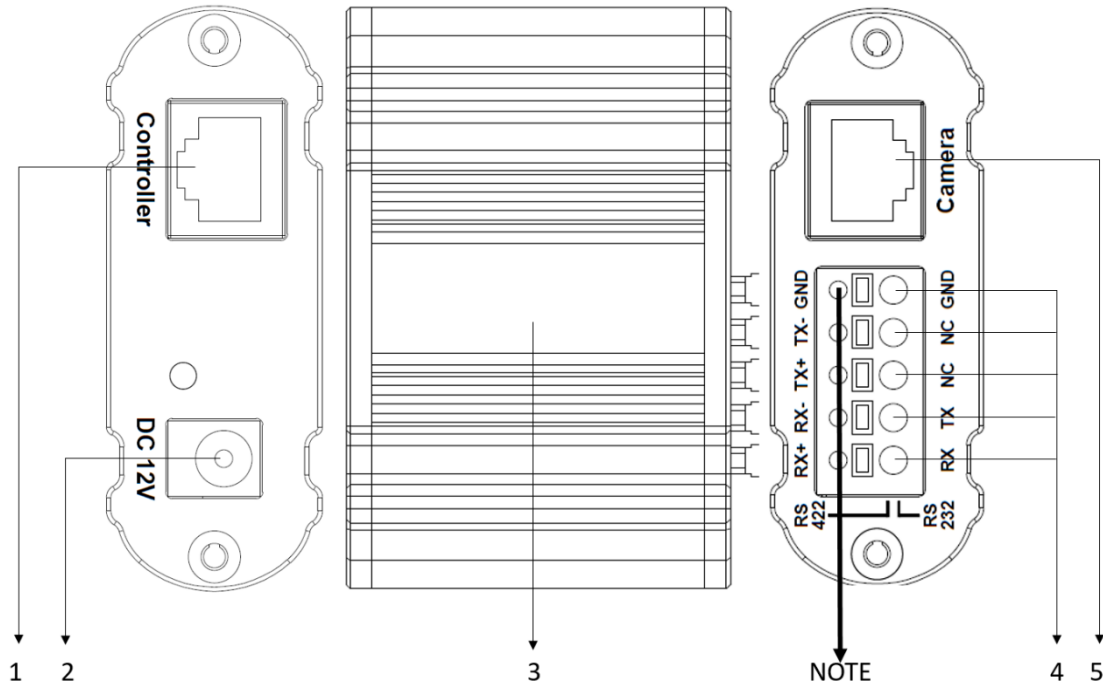

1. **RJ45 port for connection between Junction Box and The Keyboard Controller**
2. **12V DC Power Port**
Connect the supplied DC power adaptor and cord
3. **Junction Box body**
4. **Terminal Contact connection for RS422 or RS232**
5. **RJ45 port for connection between Junction Box and the camera**
Use Network cable to connect directly
6. **NOTE:** Do not use the top row of holes, as these are not contact ports. All labels apply to the **bottom row** (Item #4 in the chart)

System Overview

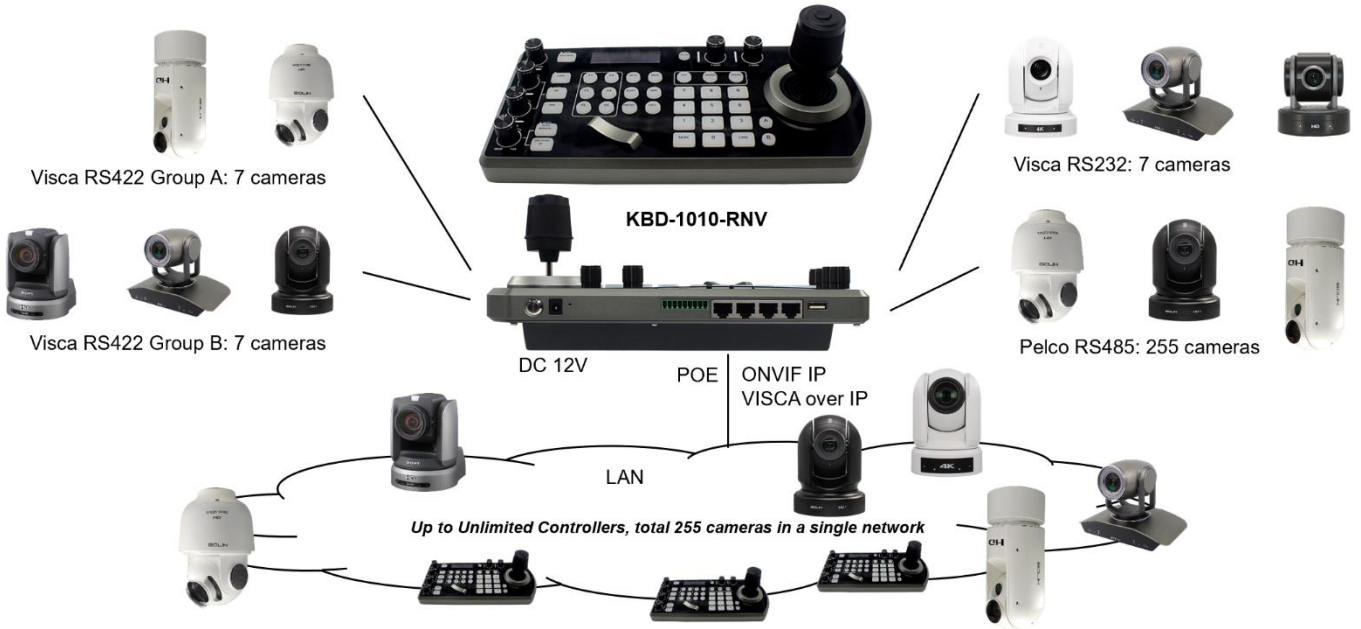

Cross Protocol Mix-control with RS232/RS422 and IP in one single system

Cross-Protocol Mix Control (PTZ Controller Mode)

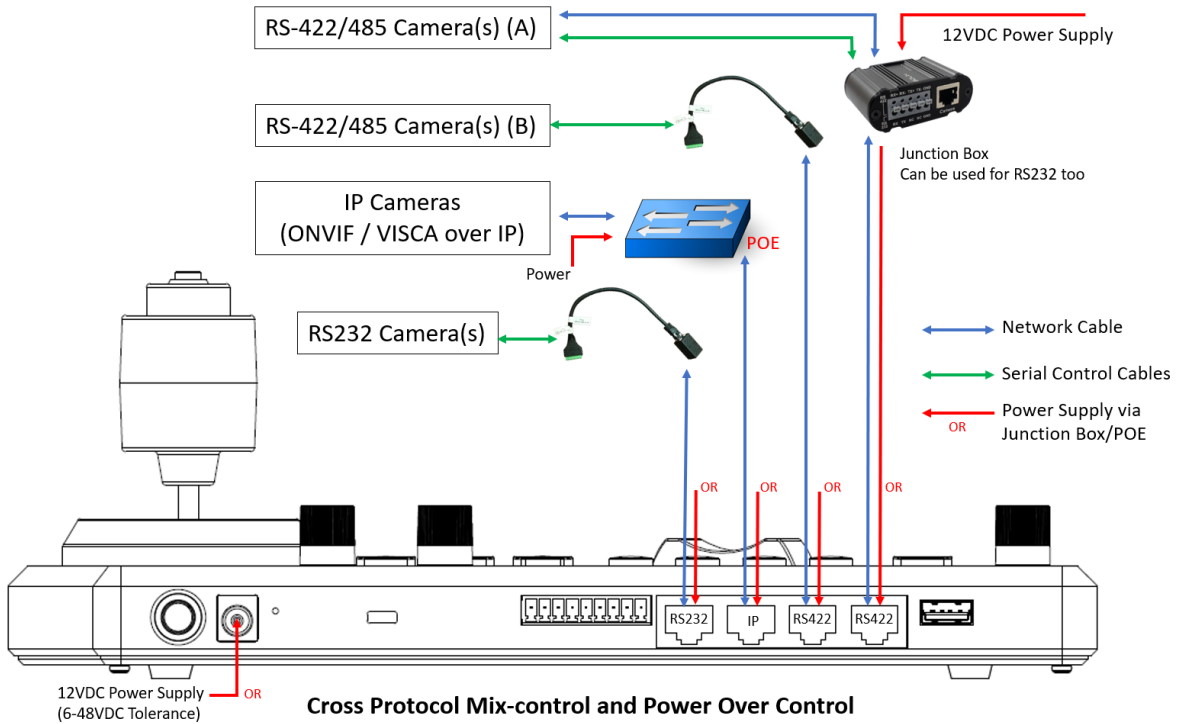

Cross Protocol Mix-control and Power Over Control

Figure 1 - When the junction box is powered, it will provide power to the keyboard via any port that it is connected to --RS232, IP, RS422(A), RS422(B). **No additional power supply is required for the keyboard a powered junction box is being used.**

Please Note, regarding Serial Control protocols (RS422/RS485 and RS232):

- When controlling only RS232 cameras, the keyboard can control a total of 7 RS232 cameras
- When controlling RS422 and RS232 cameras simultaneously, the keyboard can control a total of 7 RS232 and RS422 cameras

- When controlling only RS422 cameras, the keyboard can control up to 14 RS422 cameras (2 daisy chains of 7)
- When controlling only RS485 cameras, the keyboard can control up to 255 RS485 cameras.
- The keyboard can control up to 255 cameras in one single system, among mixed protocols (RS422, RS232, and IP)
- In one single system, within a same network, 128 keyboards can be used with IP protocol.

Connection

The controller supports serial RS232/RS422 and IP Cross protocol mix-control. It allows you to use RS232/RS422/IP control on one controller to control cameras (Protocol support: VISCA, PELCO D/P, ONVIF, VISCA over IP, CGI*) in a single system.

Power

Power up the controller using one of the following options:

1. Power supply (included) directly connect to the keyboard:
 - **Power Voltage Tolerance 6V – 48V**
 - **The keyboard can be powered with at least 6VDC. This allows for longer power runs between the power source and the keyboard**
 - **The keyboard can also tolerate 48VDC power, which makes the keyboard suitable for vehicle use (Broadcast vans, commercial vehicles, etc.)**
2. Use POE
 - Connect Ethernet IP port to POE switch using CAT5/6 network cable
 - POE standard: IEEE802.33at
 - Maximum distance 80M using CAT6 Plus cable
3. Use included junction box
 - Connect power supply to the junction box.
 - Connect Ethernet cable from “Controller” port on the junction box to the RS422 or RS232 port on the KBD-1010.
 - When using Junction Box to provide power to the keyboard via RS422 or RS232 port on the keyboard. Does not need extra power supply for keyboard.

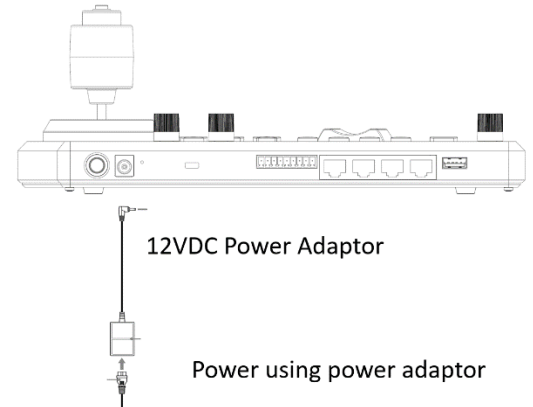

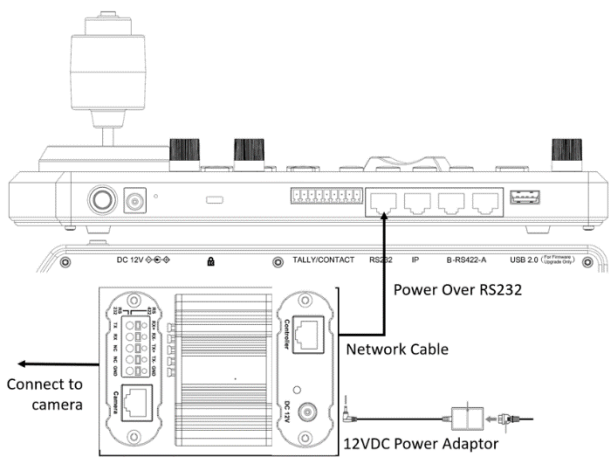

Power using Junction Box Power Over RS232

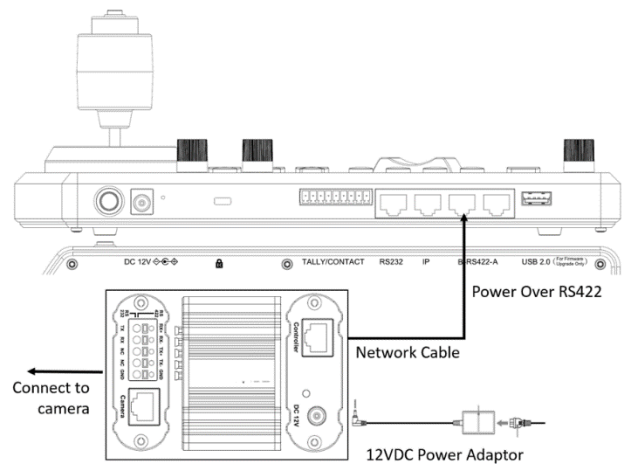

Power using Junction Box Power Over RS422

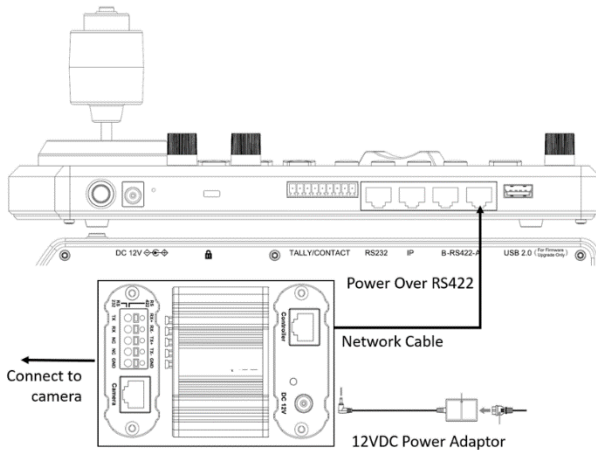

Power using Junction Box Power Over RS422

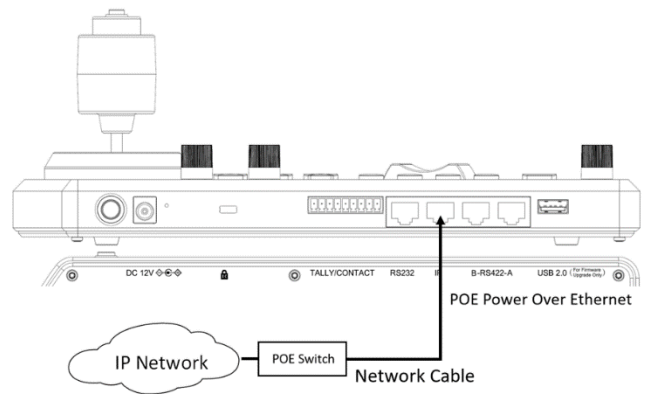



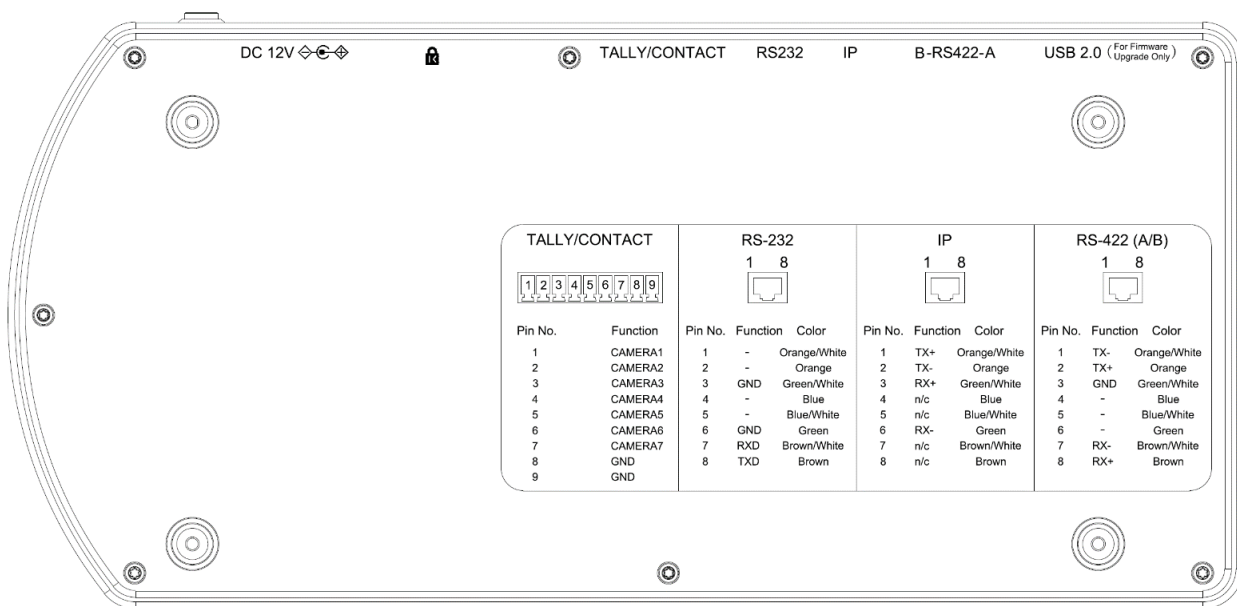

Power using POE

Figure 2 - Power supply is required at EITHER the keyboard OR the Junction Box. If the junction box is powered, no additional power supply is needed for the keyboard, as the junction box will provide power to the keyboard via the control port

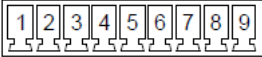
Connector Pinout Definition



TALLY/CONTACT			RS-232			IP			RS-422 (A/B)		
											
Pin No.	Function		Pin No.	Function	Color	Pin No.	Function	Color	Pin No.	Function	Color
1	CAMERA1		1	-	Orange/White	1	TX+	Orange/White	1	TX-	Orange/White
2	CAMERA2		2	-	Orange	2	TX-	Orange	2	TX+	Orange
3	CAMERA3		3	GND	Green/White	3	RX+	Green/White	3	GND	Green/White
4	CAMERA4		4	-	Blue	4	n/c	Blue	4	-	Blue
5	CAMERA5		5	-	Blue/White	5	n/c	Blue/White	5	-	Blue/White
6	CAMERA6		6	GND	Green	6	RX-	Green	6	-	Green
7	CAMERA7		7	RXD	Brown/White	7	n/c	Brown/White	7	RX-	Brown/White
8	GND		8	TXD	Brown	8	n/c	Brown	8	RX+	Brown
9	GND										

IP connection

Connect the keyboard's "IP" port to a port on an Ethernet switch

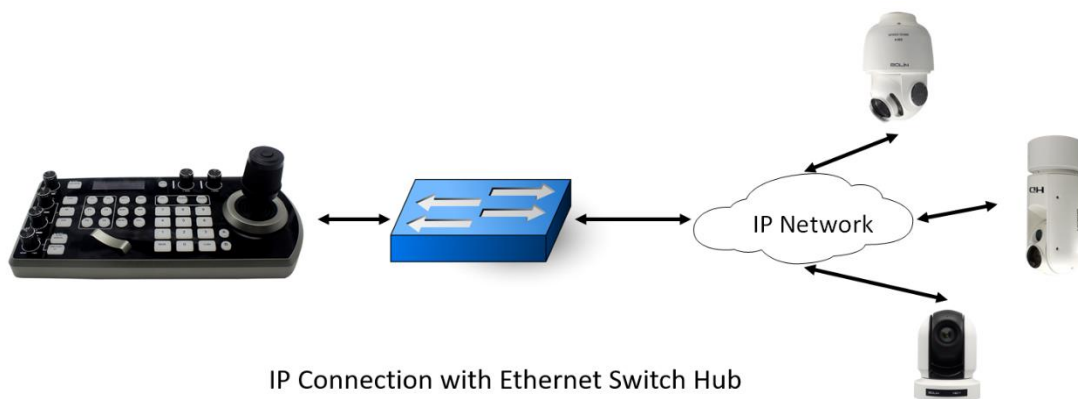

For more information regarding adding ONVIF and VISCA over IP cameras to be controlled by the keyboard, please see the section on [Keyboard IP Configuration](#)

Make Serial Port Connection

The controller supports serial RS232/RS422 and IP Cross protocol mix-control. It allows you to use RS232/RS422/IP control on one controller to control cameras (Protocol support: VISCA, PELCO D/P, ONVIF, VISCA over IP) in a single system.

Depending on the protocol being used to control the cameras, you may need to connect one or more of the following:

IP port to network switch

- Used for logging in to web interface of KBD-1010
- Used to control the following PTZ protocols:
 - VISCA over IP
 - ONVIF IP

RS232 Connection

- RS232 Connection 1 to 1 connection with keyboard and camera
- Keyboard connection to RS232 daisy chain

RS232 connection

-Use for the controller with Non-Bolin camera connection. Bolin camera connection see the separate section following.

Follow the diagram below for the following options:

1. **RS232 connection using network cable (follow T-568B standard pinout at keyboard end):**
 - a. **1 to 1 connection - Follow the pinout for the RS232 port on the keyboard to use CAT5/6 cable to make a cable suitable for controlling your camera.**

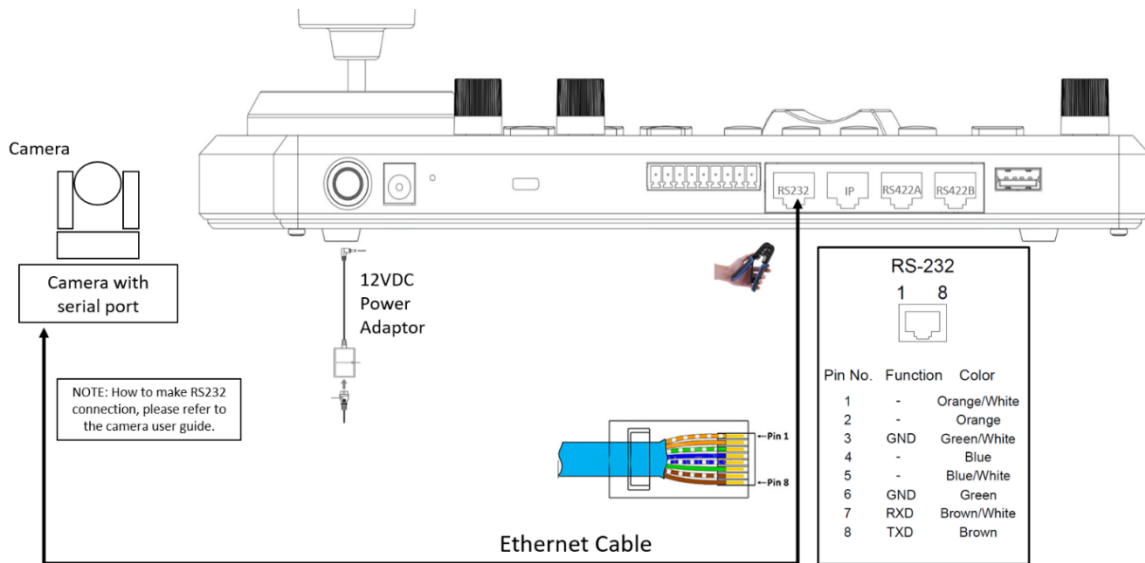

RS232 connection – Make a Network cable - Camera with RS232 Serial Port connector

- b. **Use Junction Box, 1 to 1 connection - Follow the pinout for the RS232 port on the keyboard and Junction Box to use CAT5/6 cable (follow T-568B standard pinout between keyboard and Junction Box) to make a cable suitable for controlling your camera via Junction Box.**

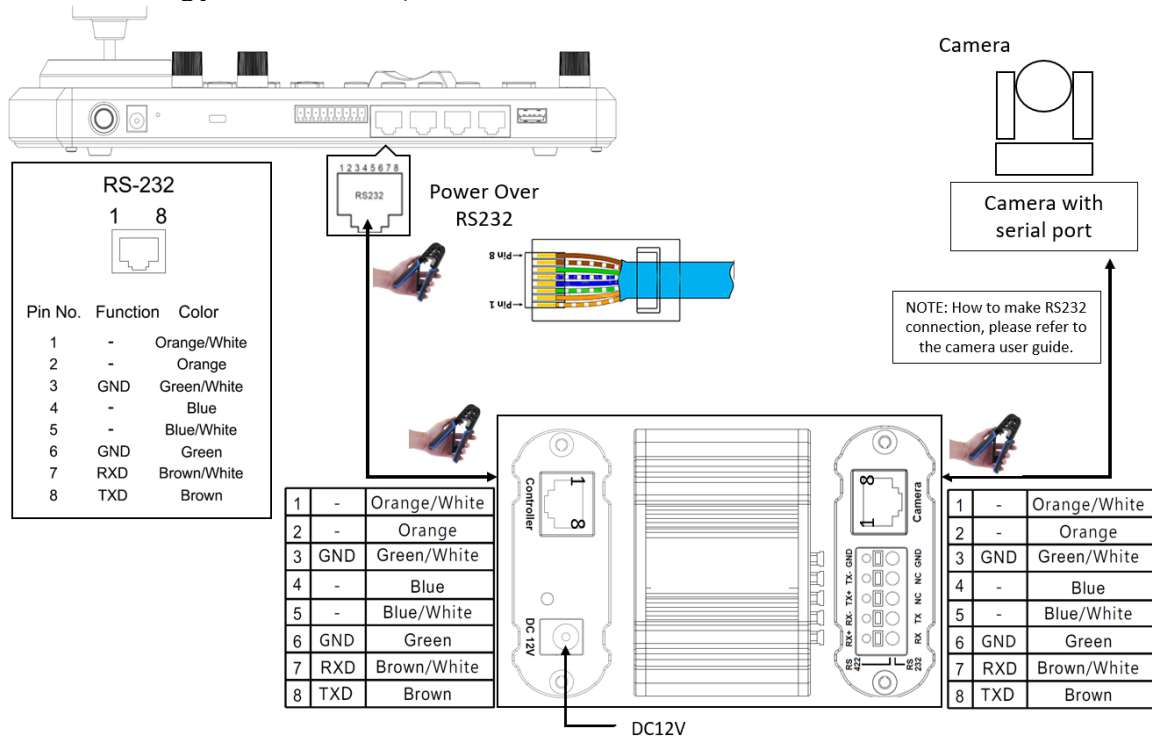

RS232 connection – Via Junction Box to make a network cable - Camera with RS232-Serial connector

2. RS232 connection using multicore control cable

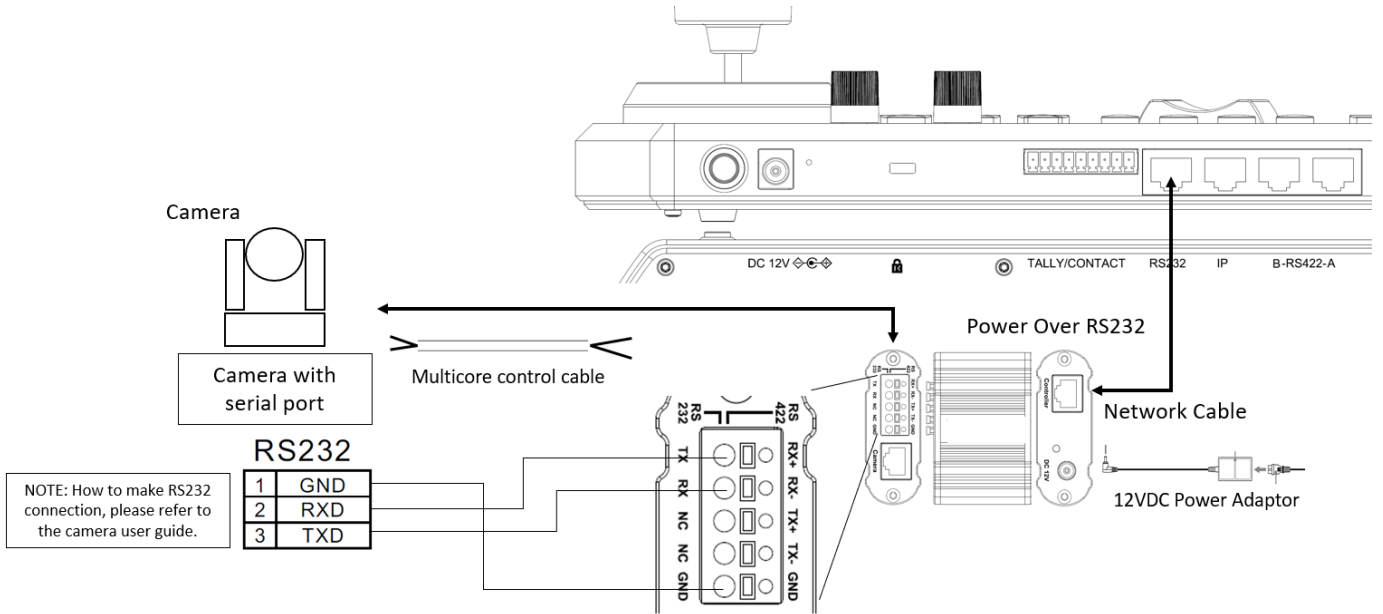

RS232 Connection – Via Junction Box - Camera with RS232 serial connector

3. RS232 connection with the camera having 8 Pin Mini Din RS232 connector.

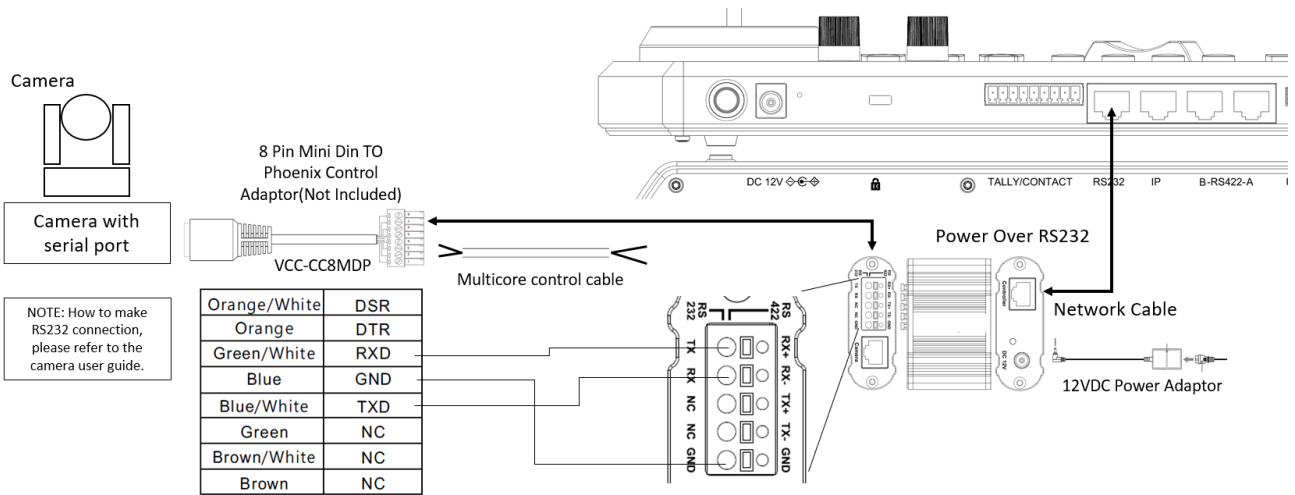

RS232 Connection – Via Junction Box - Camera with 8 Pin Mini Din RS232 serial connector

4. RS232 Daisy Chain Multiple Cameras connection via Junction Box:

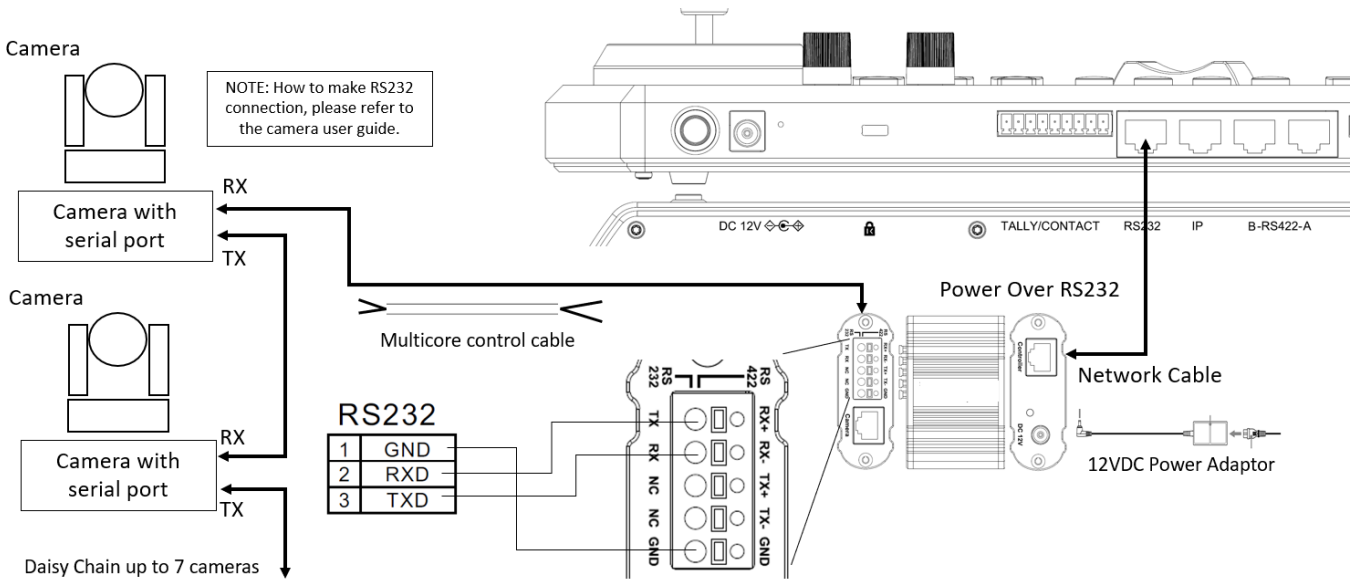

RS232 Daisy Chain Connection – Via Junction Box - Camera with RS232 serial connector

5. RS232 connection using RJ45 to Phoenix connector adaptor (Not Included, sold separately)

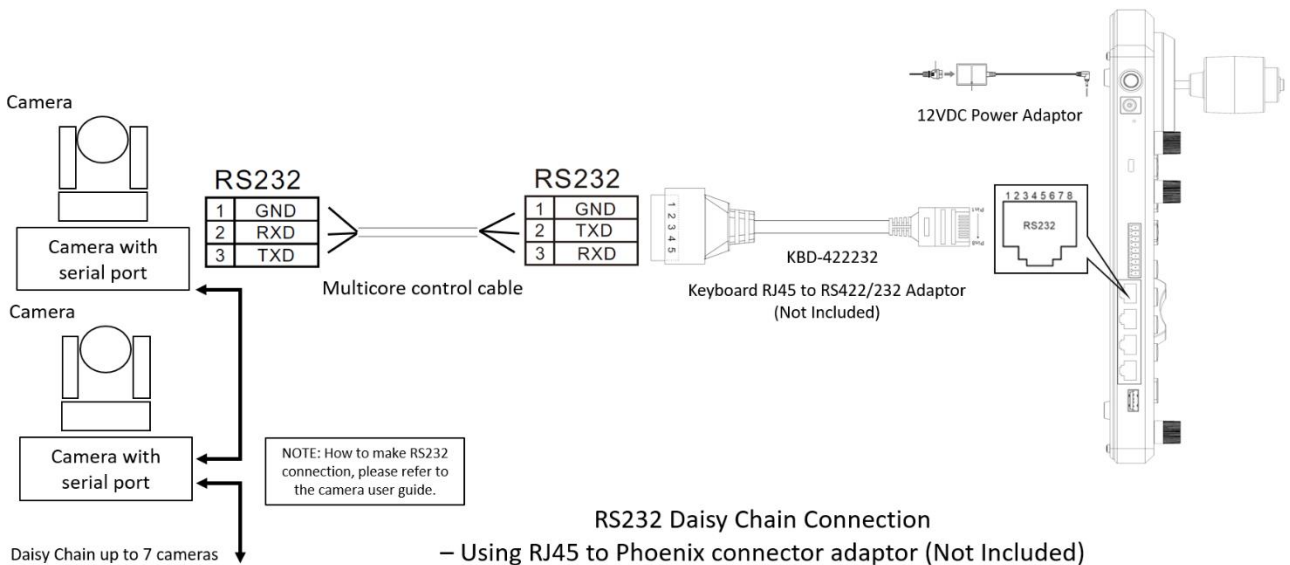

RS422 connection

-Use for the controller with Non-Bolin camera connection. Bolin camera connection see the separate section following.

There are two connection ways for the RS422 ports on keyboard rear panel

1. When Control Mode select **PTZ Controller** in Keyboard Setting:
 - Keyboard RS422 (A or B) RJ-45 port are used for RS422 camera control.
 - Keyboard RS422 (A or B) RJ-45 port are used for RS485 cameras control
2. When Control Mode select **Video Router Switch** in Keyboard Setting
 - Keyboard RS422 (A) RJ-45 port is used to connect with Video Router/Matrix for video switching control
 - Keyboard RS422 (B) RJ-45 port is used to connect RS422 camera or RS485 camera control.

Follow the diagram below for the following options:

1. RS422 connection using network cable (follow T-568B standard pinout at keyboard end):
- a. 1 to 1 connection – Follow the pinout for the RS422 port on the keyboard to use CAT5/6 cable to make a cable suitable for controlling your camera.

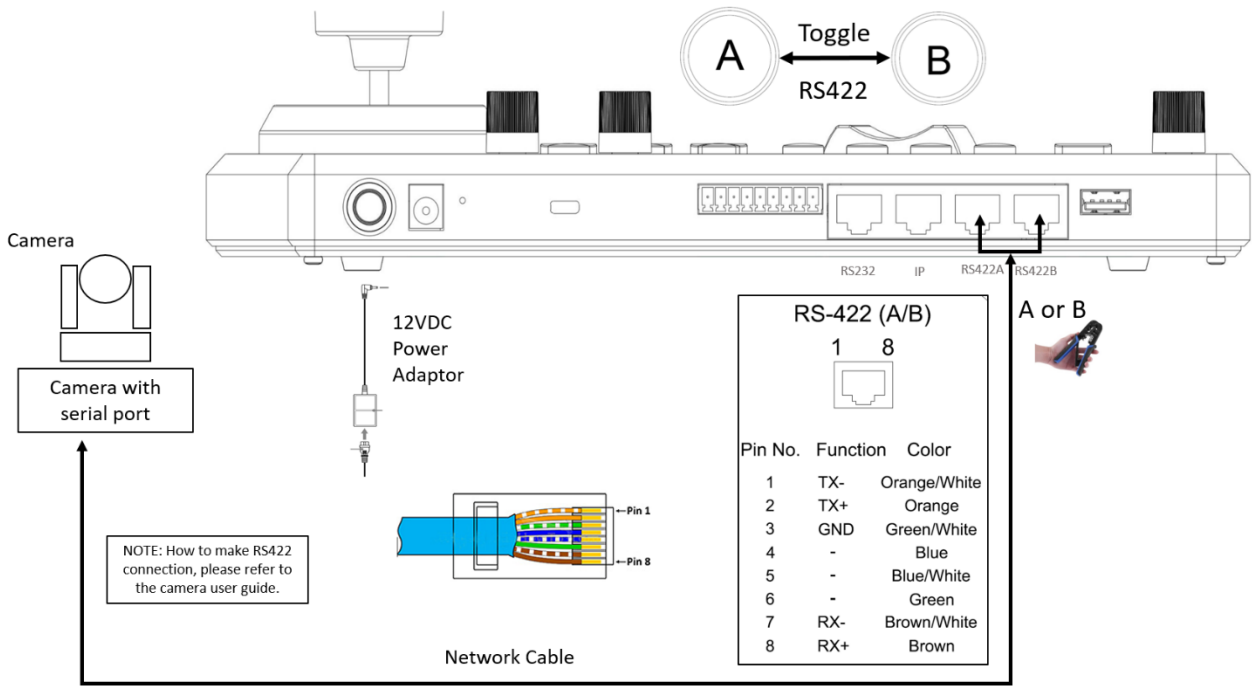

RS422 Connection – Make a network cable - Camera with RS422 serial connector

- b. 1 to 1 connection, Use Junction Box– Follow the pinout for the RS422 port on the keyboard and Junction Box to use CAT5/6 cable (follow T-568B standard pinout between keyboard and Junction Box) to make a cable suitable for controlling your camera via Junction Box.

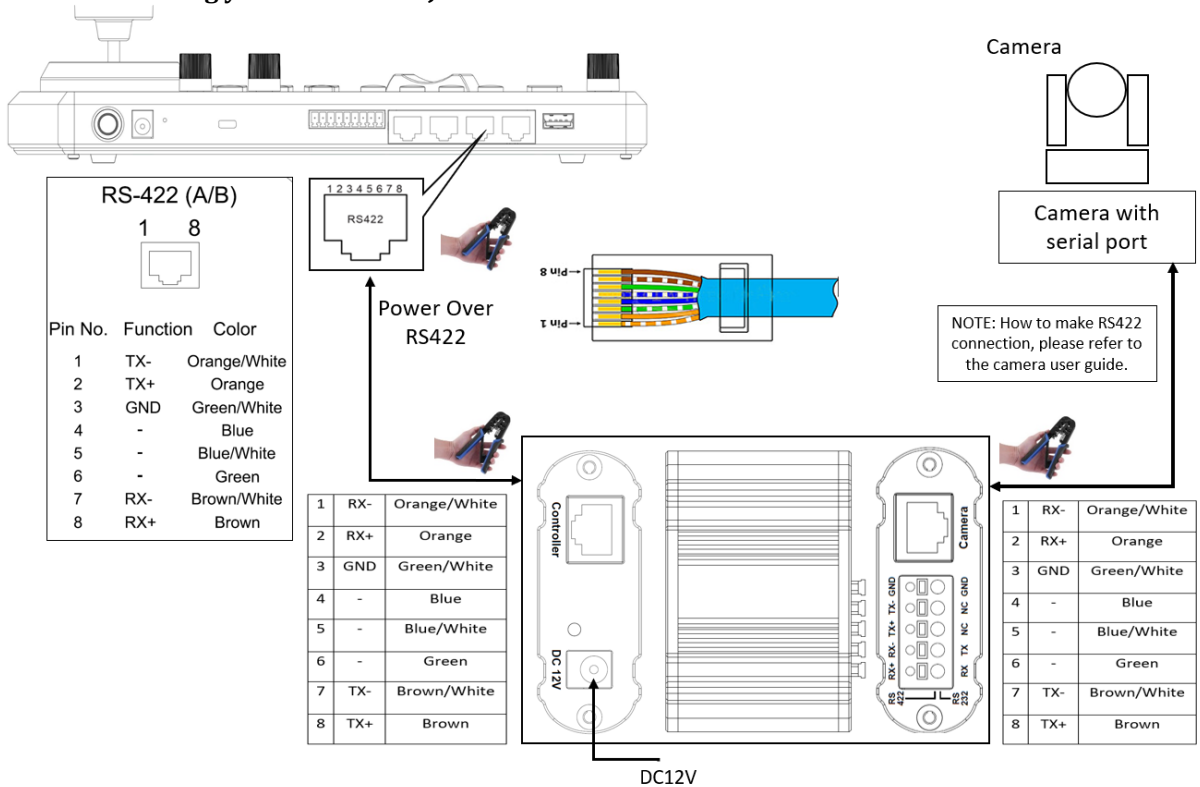

RS422 Connection – Via Junction Box to make a network cable - Camera with RS422 serial connector

2. RS422 connection using multicore control cable (Non-SONY Camera)

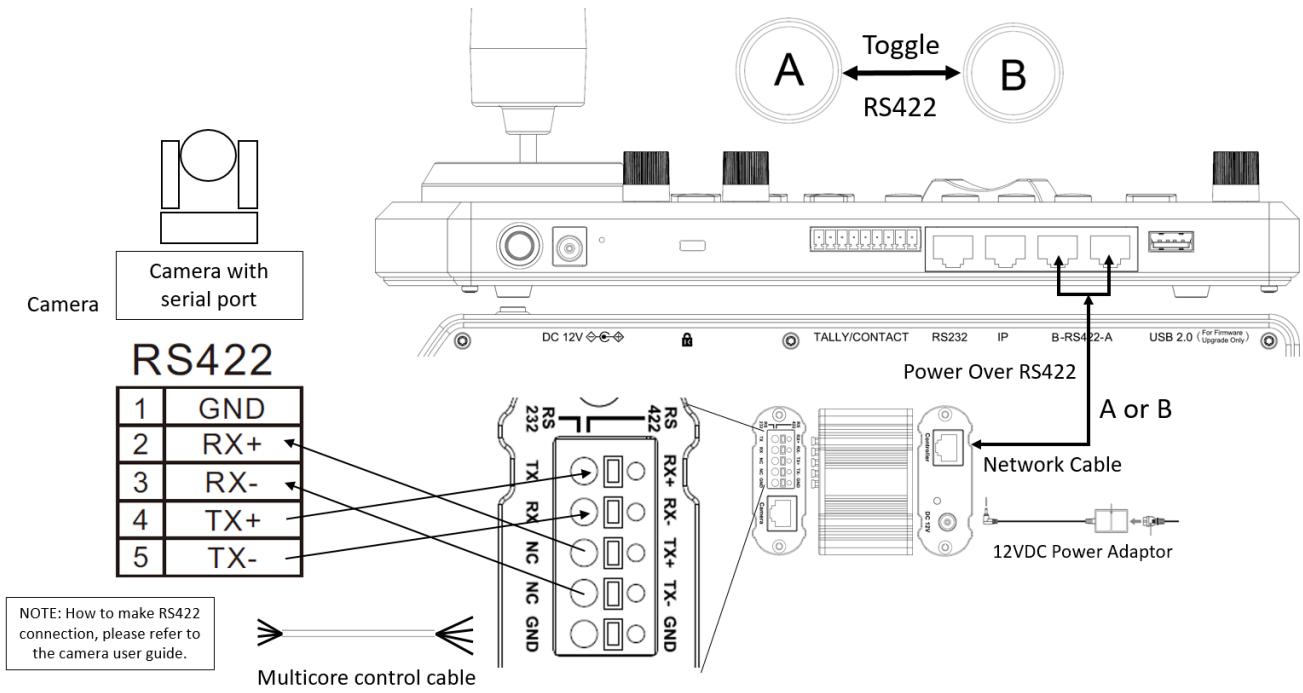

RS422 Connection – Via Junction Box - Camera with RS422 serial connector

3. RS422 connection using multicore control cable (SONY Camera)

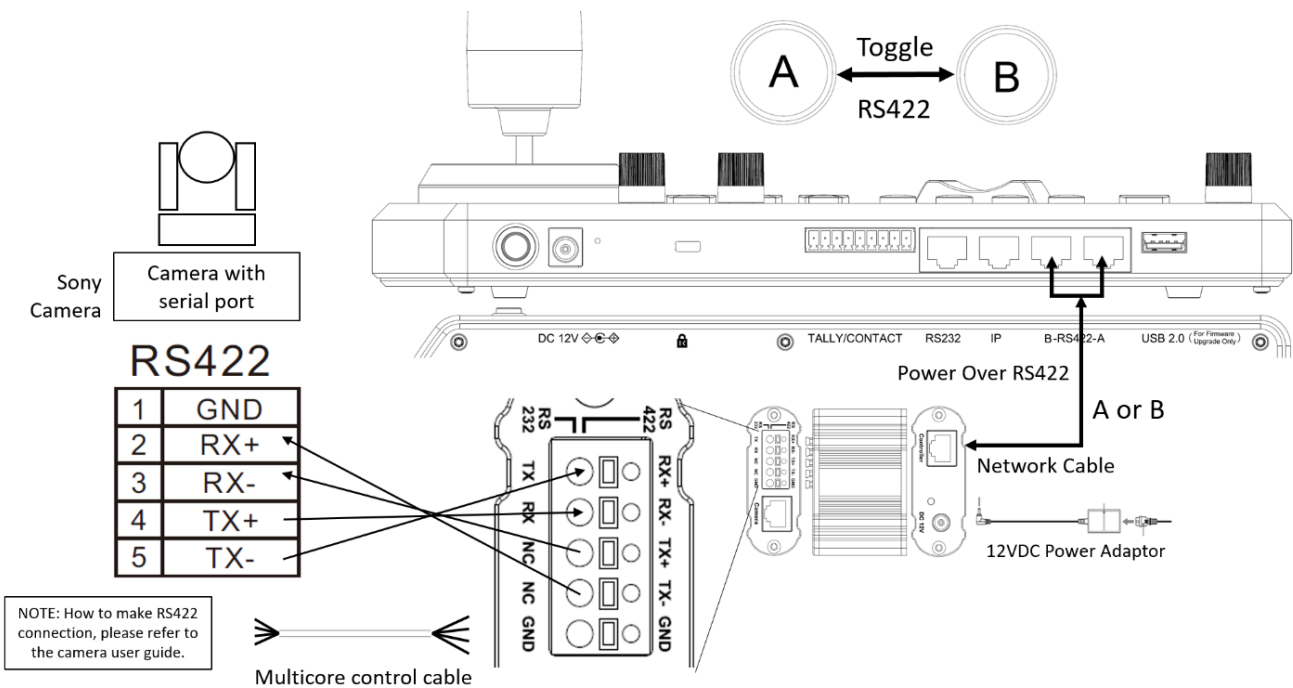

(SONY Camera) RS422 Connection – Via Junction Box - Camera with RS422 serial connector

4. RS422 Daisy Chain Multiple Cameras connection (Non-Sony Camera)

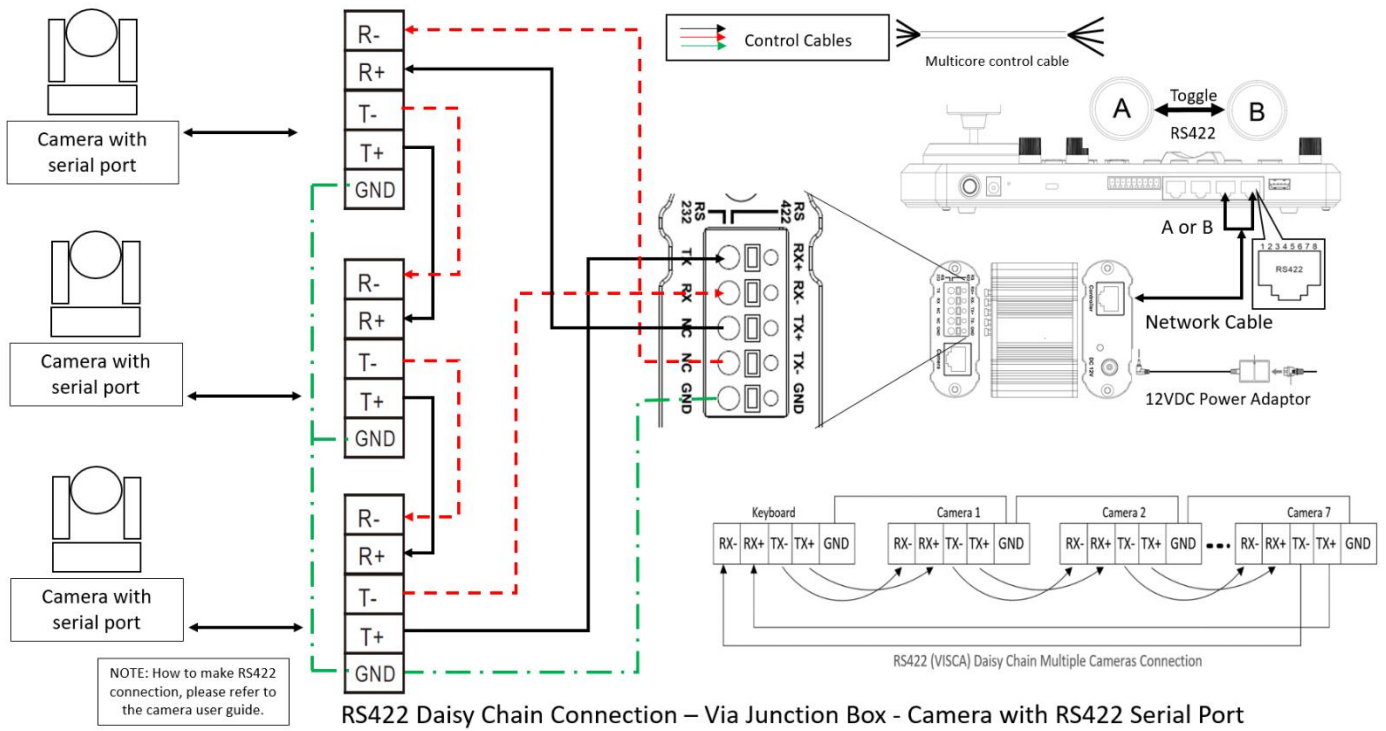

5. RS422 Daisy Chain Multiple Cameras connection (Sony Camera)

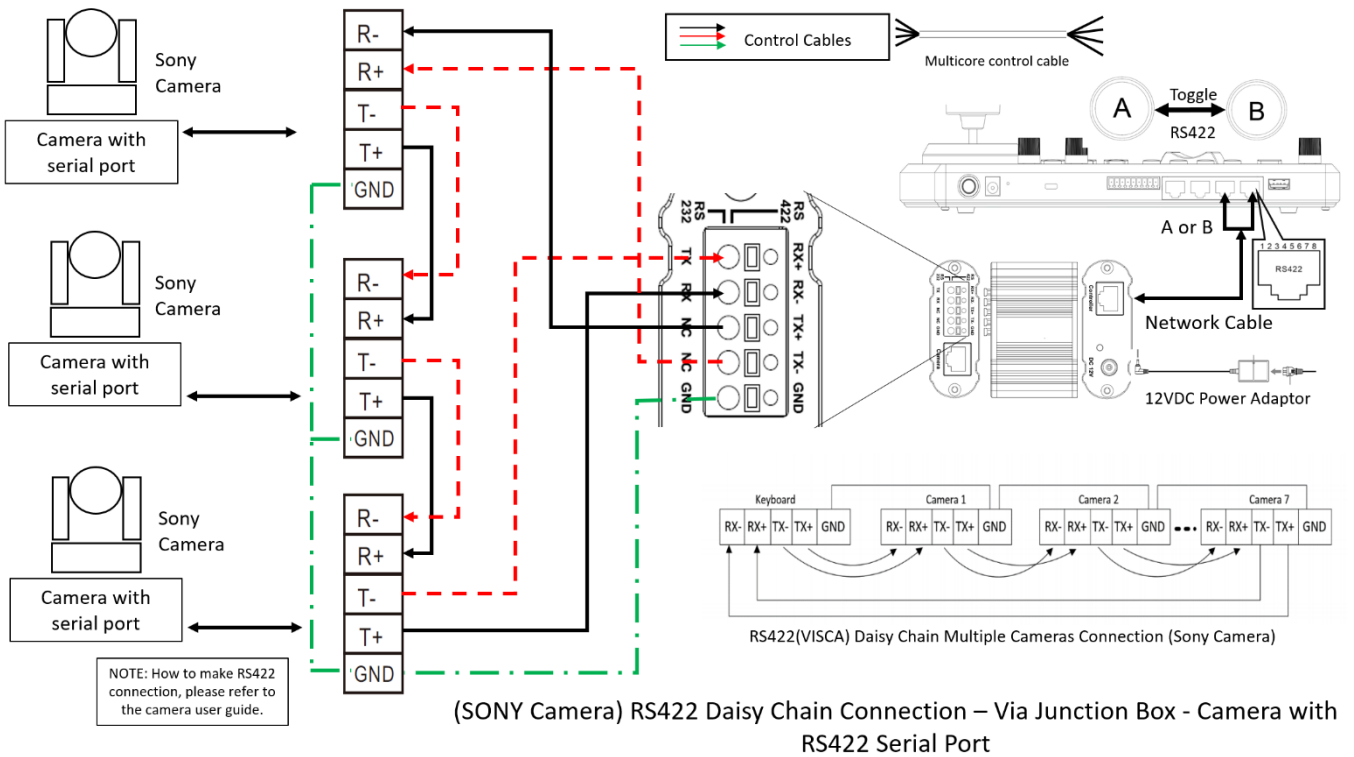

6. RS422 1 to 1 connection using RJ45 to Phoenix connector adaptor (Not Included, sold separately)

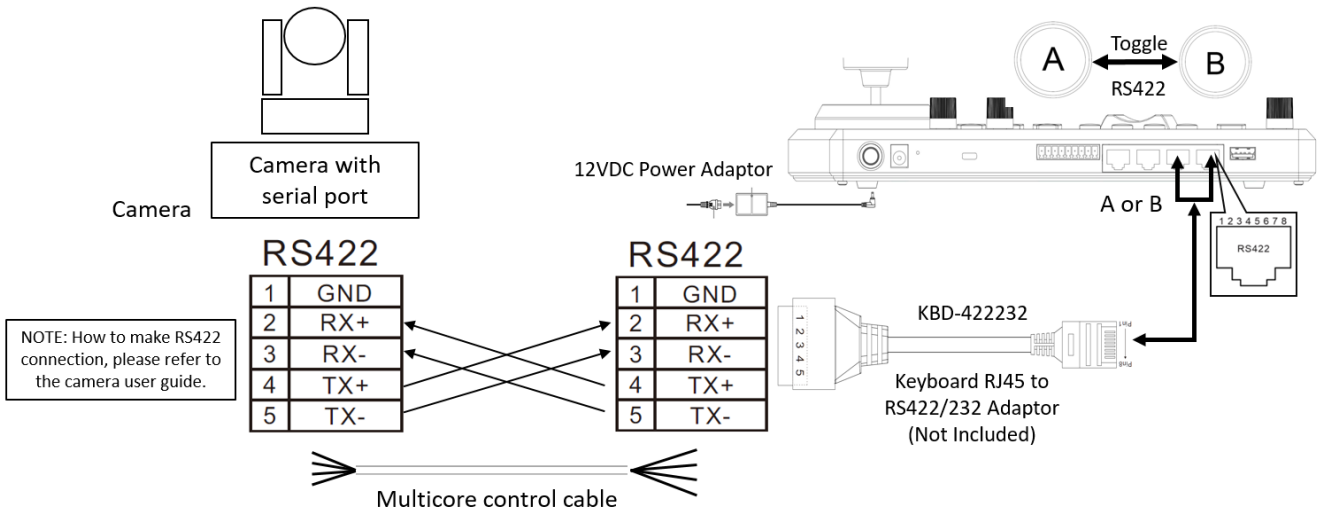

RS422 Connection - Use RJ45-RS422 adaptor - Camera with RS422 serial connector

7. RS422 Daisy Chain connection using RJ45 to Phoenix connector adaptor (Not Included, sold separately)

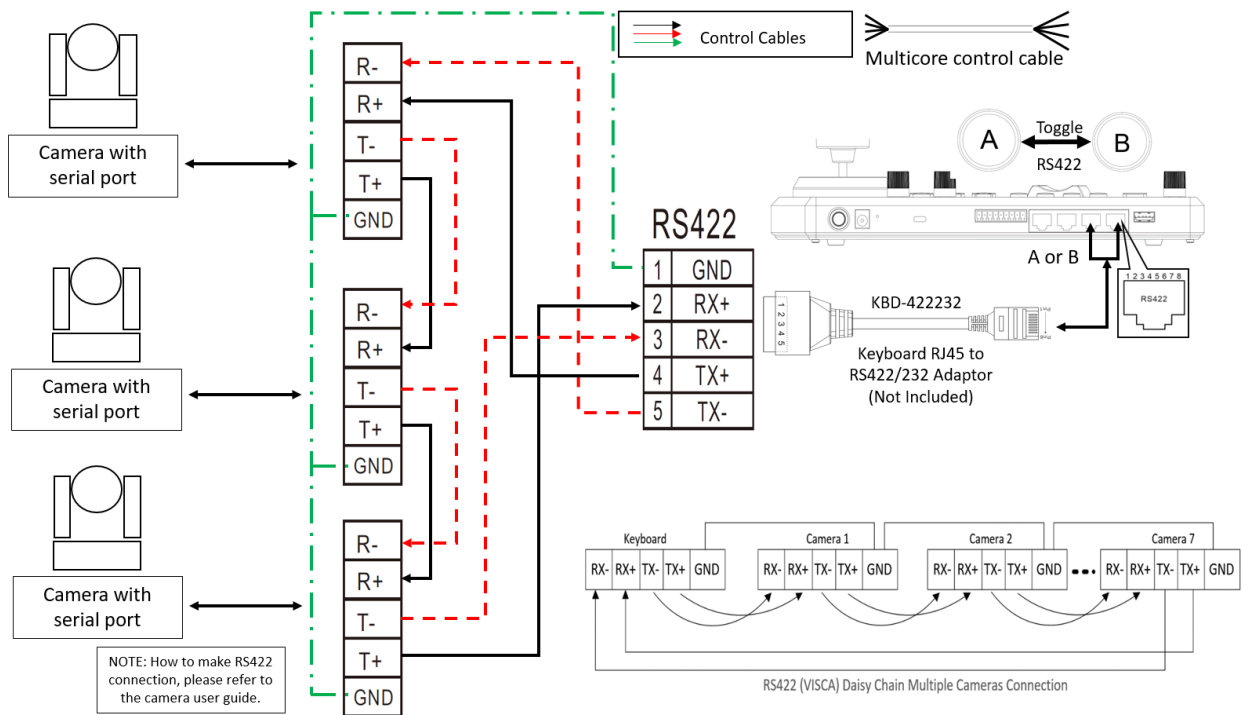

RS422 Daisy Chain connection – Via RJ45 to RS422/232 Adaptor - Camera with RS422 Serial Port

RS485 connection

-Use for the controller with Non-Bolin camera connection. Bolin camera connection see the separate section following.

Follow the diagram below for the following options:

NOTE:

- Use RS422 ports for RS485 connection.
- Only use TX+ and TX- for RS485 connection.

1. RS485 connection using network cable (follow T-568B standard pinout at keyboard end):
 - a. 1 to 1 connection - Follow the pinout for the RS485 port on the keyboard to use CAT5/6 cable to make a cable suitable for controlling your camera.

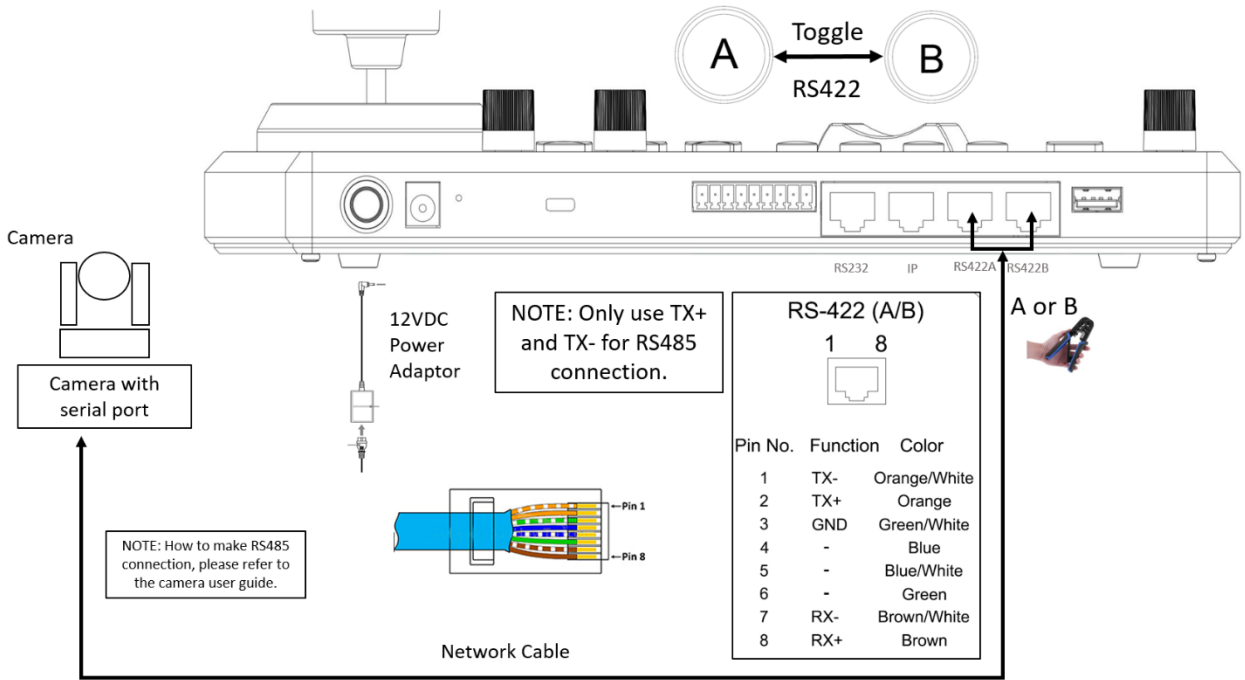

RS485 Connection – Make a network cable - Camera with RS485 serial connector

- b. Use Junction Box, 1 to 1 connection - Follow the pinout for the RS485 port on the keyboard and Junction Box to use CAT5/6 cable (follow T-568B standard pinout between keyboard and junction box) to make a cable suitable for controlling your camera via Junction Box.

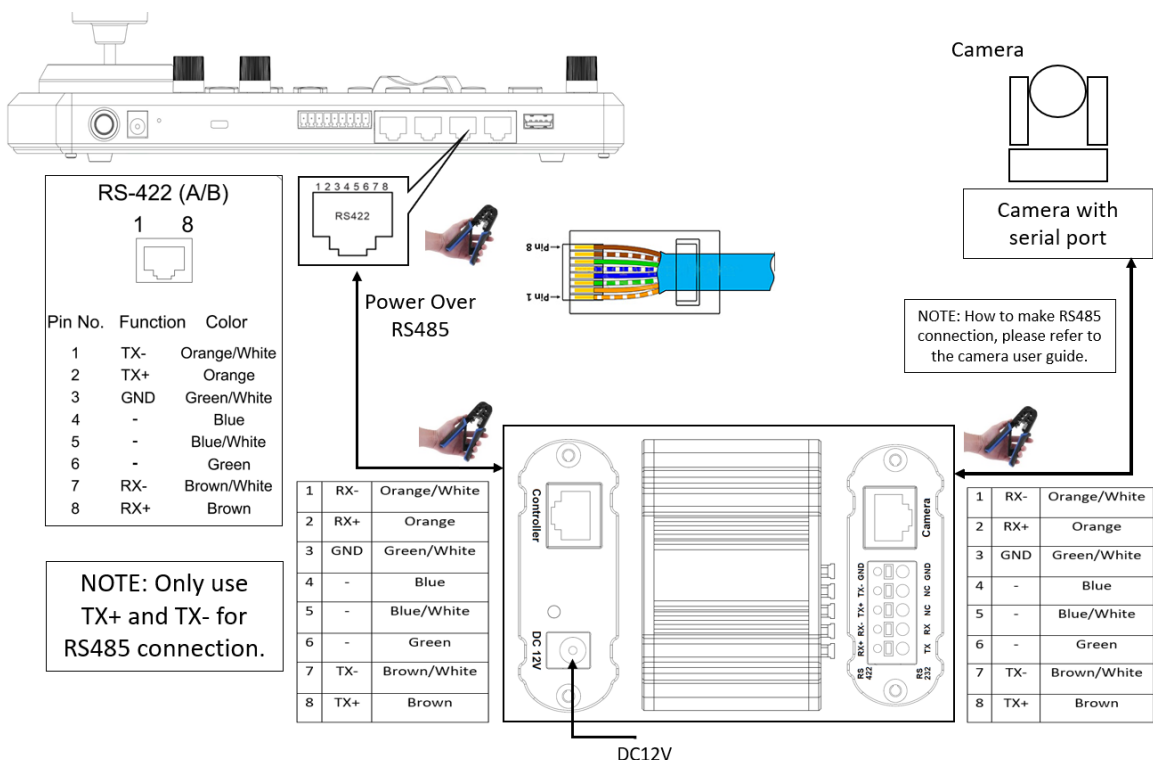

RS485 Connection – Via Junction Box to make a network cable - Camera with RS485 serial connector

2. RS485 connection using multicore control cable via Junction Box

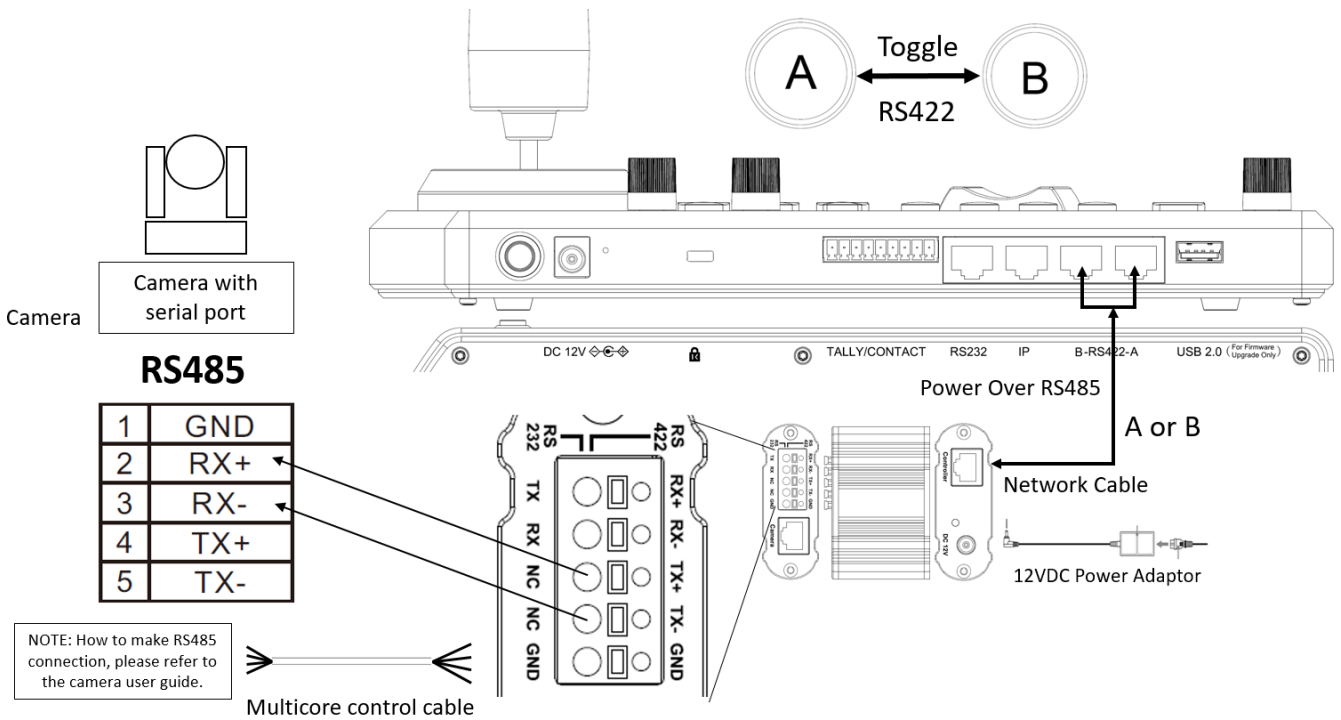

RS485 Connection – Via Junction Box - Camera with RS485 serial connector

3. RS485 connection using multicore control cable via RJ45 to Phoenix connector adaptor (Not Included, sold separately)

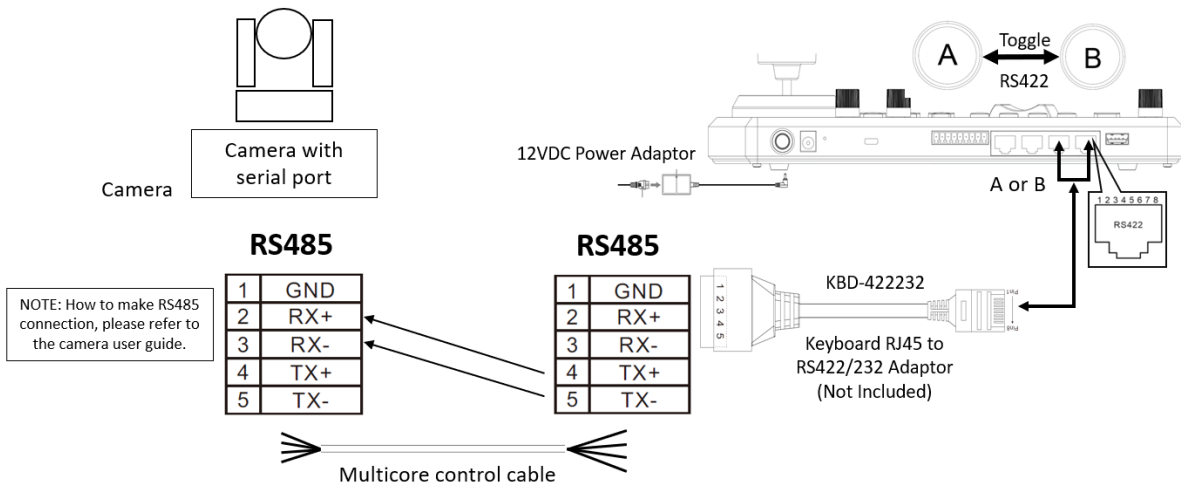

RS485 Connection - Use RJ45-RS422 adapter - Camera with RS485 serial connector

4. RS485 Daisy Chain Multiple Cameras connection

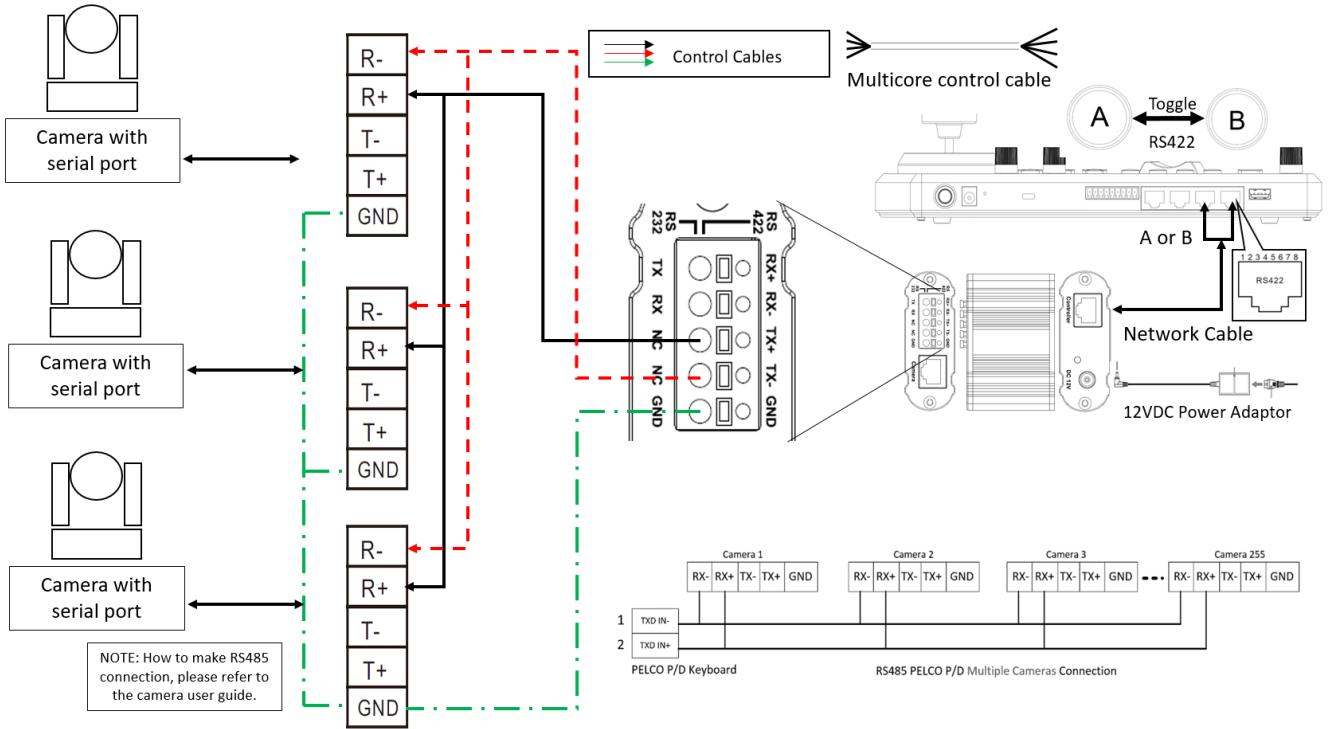

5. RS485 Daisy Chain connection using RJ45 to Phoenix connector adaptor (Not Included, sold separately)

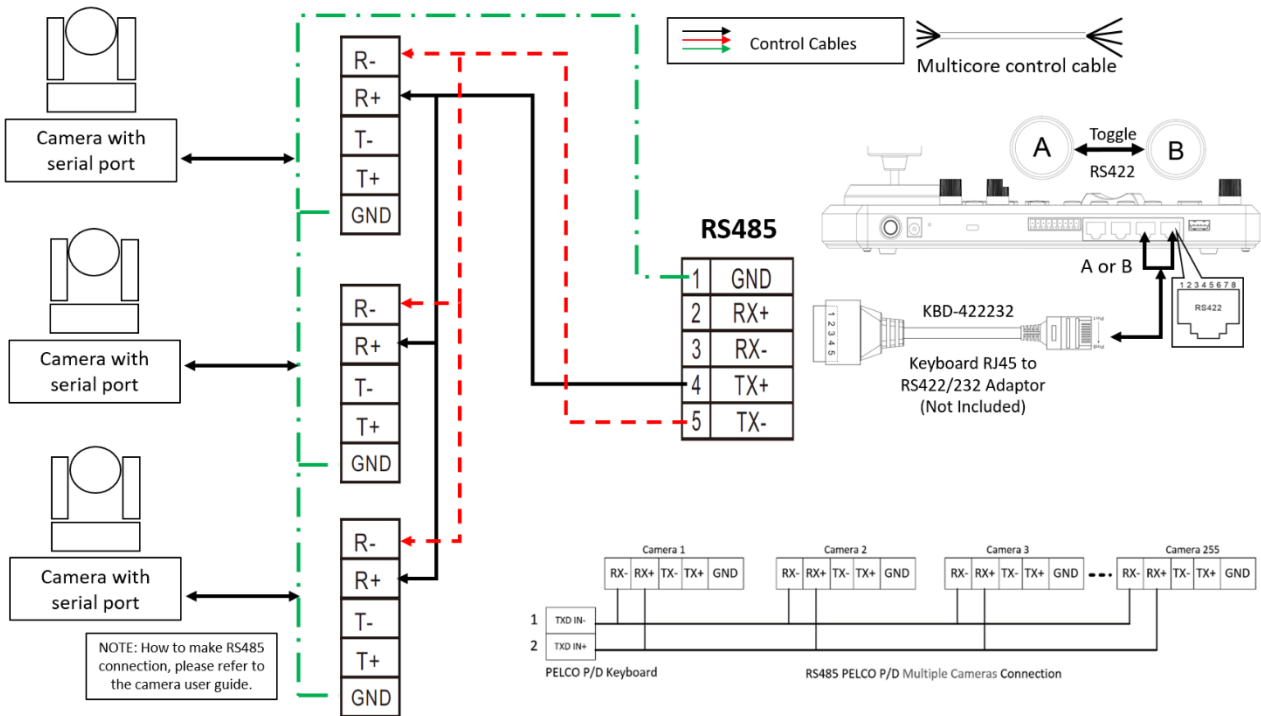

IP Control

Use ONVIF IP Control:

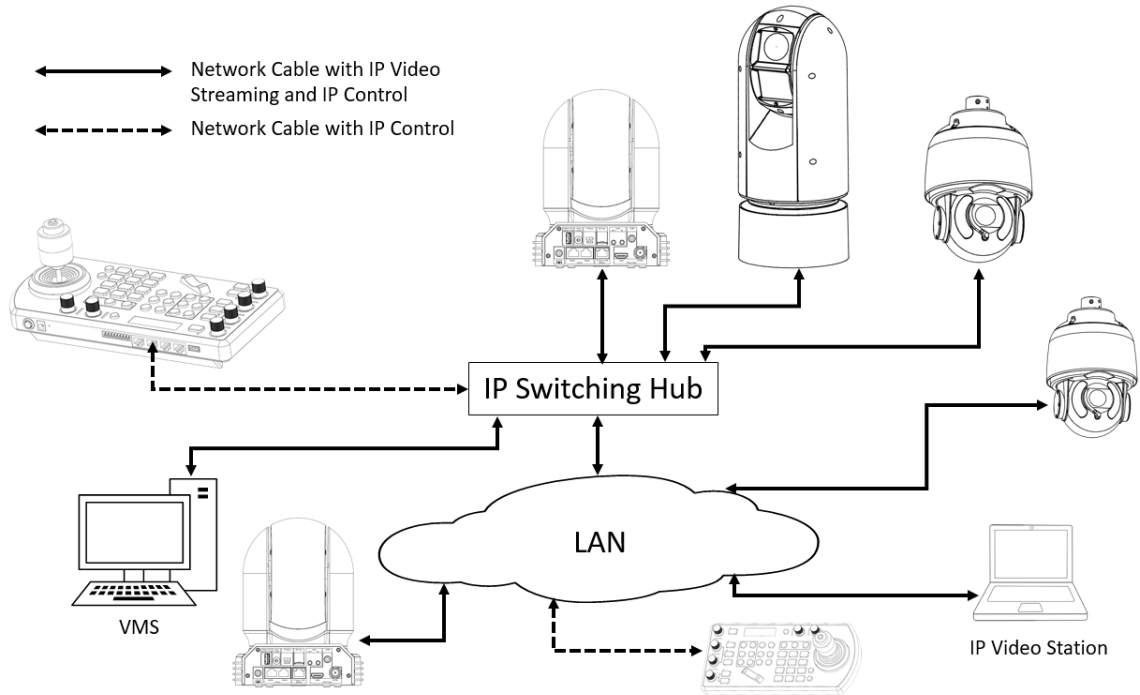

IP Connection – Using ONVIF IP Control Protocol – With IP Streaming Camera

Use VISCA OVER IP Control:

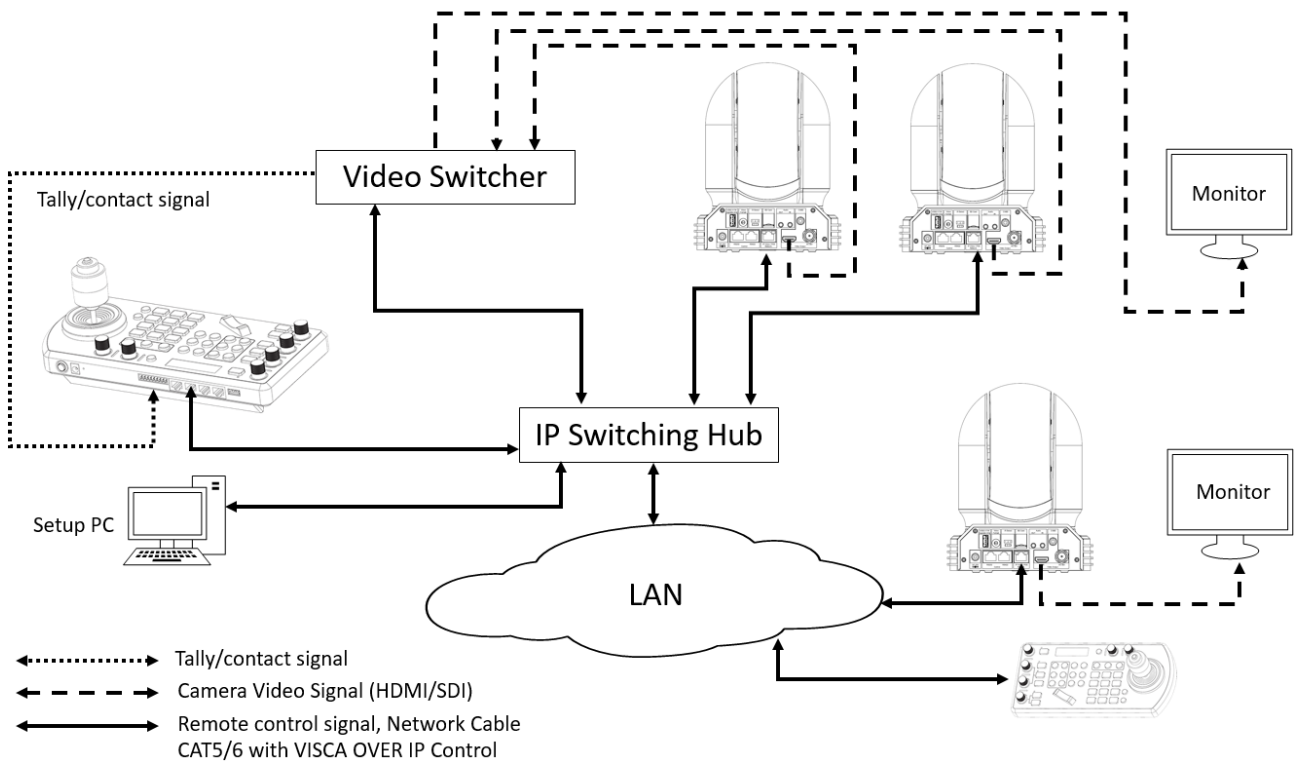

IP Connection – Using VISCA OVER IP Control Protocol – With Visca Over IP ready Camera

Cross-Protocol Mix Control

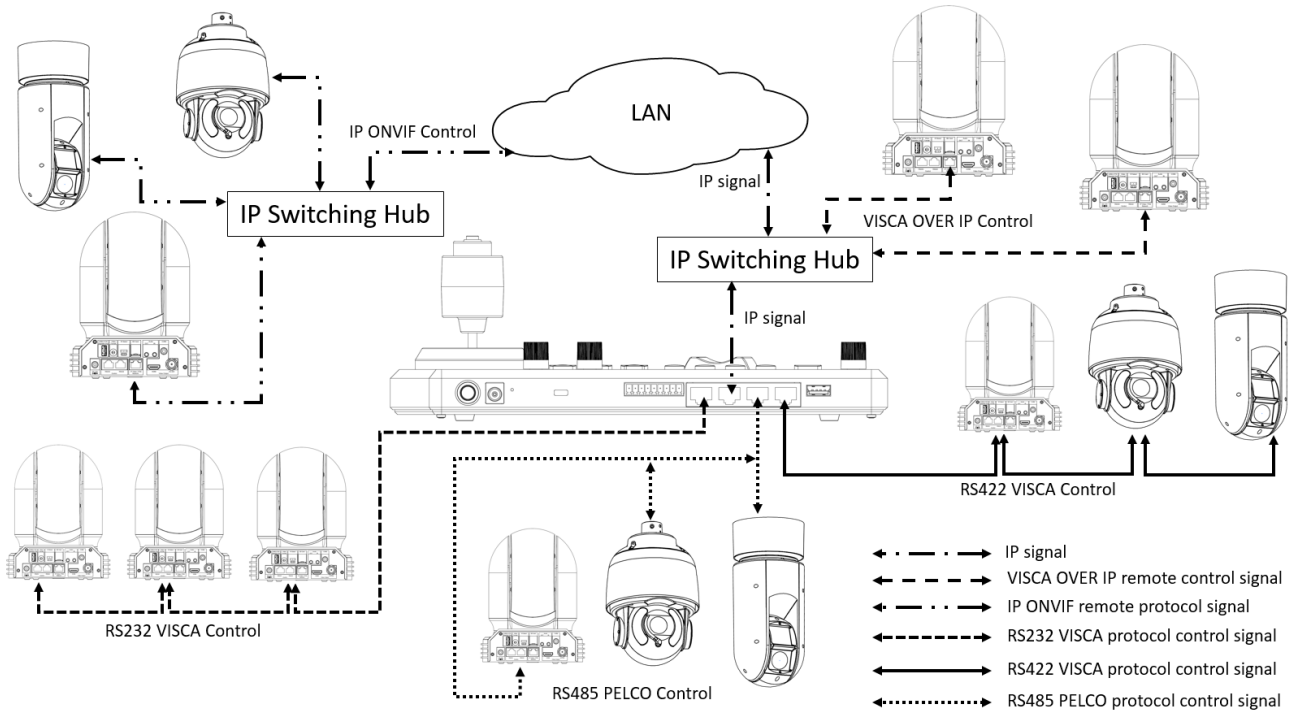

Cross-Protocol Mix Control - Using VISCA, PELCO, VISCA OVER IP, ONVIF IP Control Protocol in one single system.

Tally Light GPI I/O connection

GPI connection with RS422 VISCA control connection

Cable Preparation

1. Build standard multiple cameras RS-422 daisy chain control connection between the keyboard controller and the cameras. (For more RS422 control information details please refer to Keyboard Controller user guide)

a. Via Junction Box

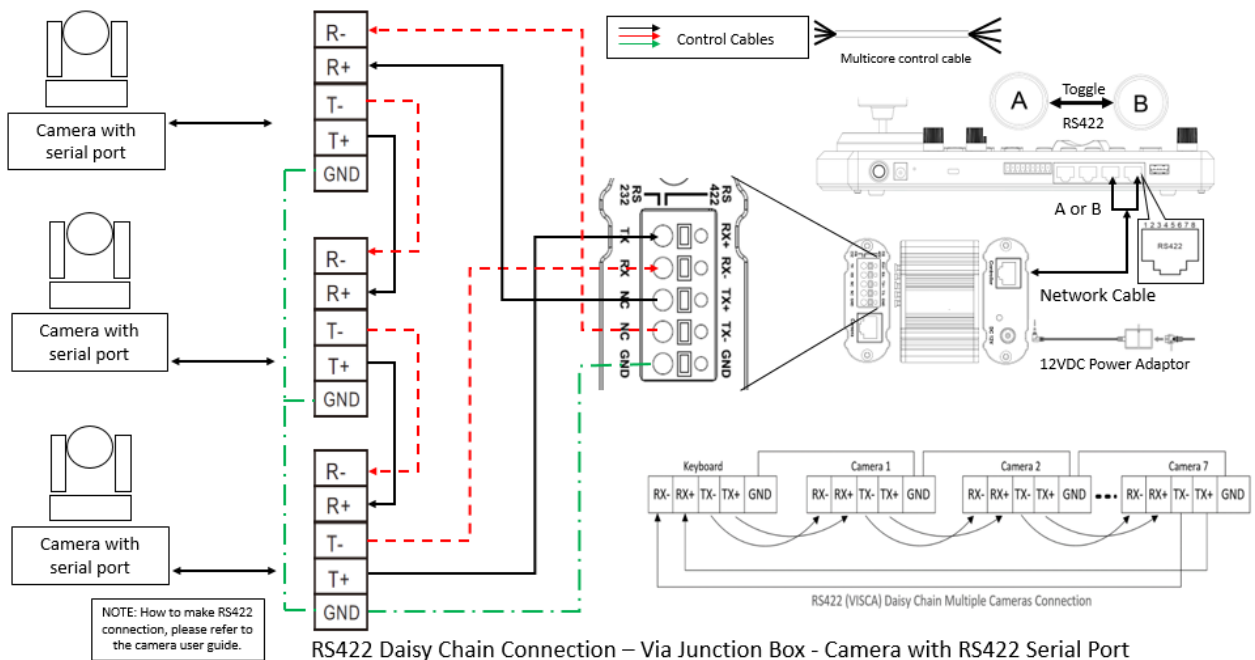

b. Via RJ45 RS422/232 adaptor

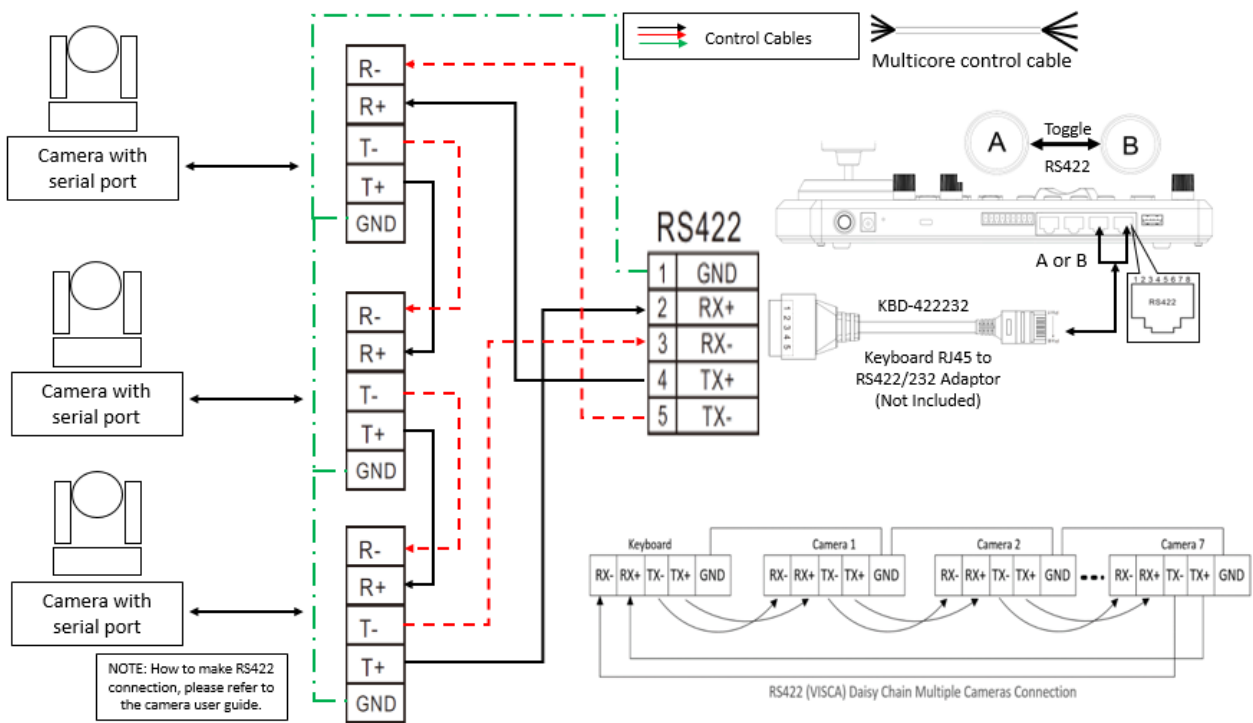

RS422 Daisy Chain connection – Via RJ45 to RS422/232 Adaptor - Camera with RS422 Serial Port

2. Built Tally/Contact Function cable connection between the Keyboard Controller and Video Switcher (Sony)

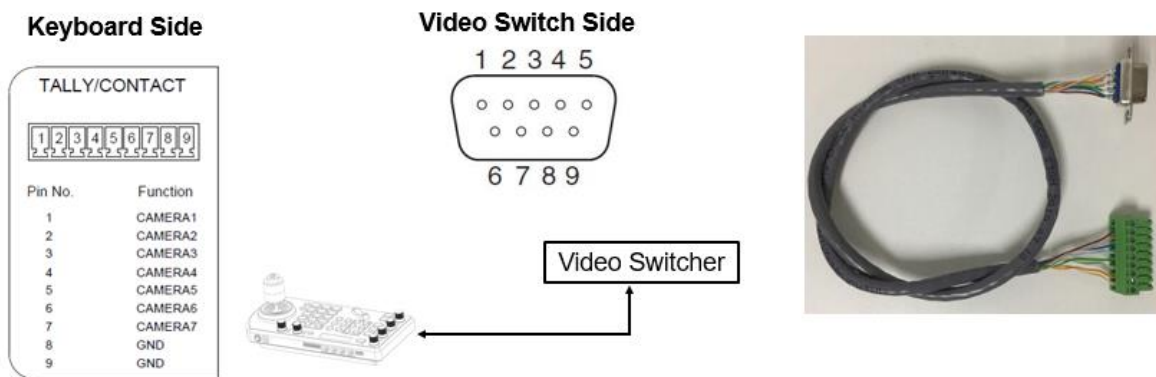

1. Keyboard side we use pin 1 to pin 8, Video Switch side we use pin 1 to pin 9 except pin 8;
2. Keyboard pin 8 connected with Video Switch pin 9;
3. Keyboard pin 1 connected with Video Switch pin 1, pin 2 connected with pin 2, the rest may be deduced by analogy, ...pin 7 connected with pin 7

Set UP

1. GPI I/O Input mode - Tally signal is sent by Video Switch
 - a. Connect camera with keyboard by standard RS-422 control cable;
 - b. Connect keyboard with video switch by tally function cable;
 - c. Access to KEYBOARD SETTING > GPI I/O > Setting, and change it to Input mode, then Exit to home directory;
 - d. After done above operations, we can switch to different camera by video switch, for example, if we switch to camera 1 on video switch, it will send tally signal to keyboard via the tally function cable,

- and keyboard will transmit this tally signal to camera 1 via standard RS-422 control cable, so camera 1 tally light will turn on, and keyboard can control camera 1 pan and zoom;
- e. If switch to camera 2 on video switch, then camera 2 tally light will on and camera 1 tally light will off;

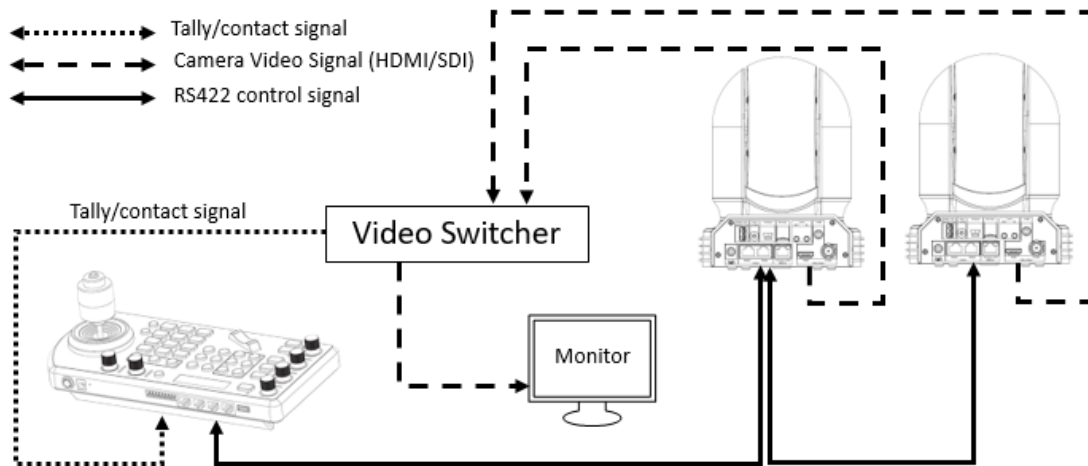

Tally Light GPI Connection – Using RS422 VISCA Control Protocol

Diagram when GPI is select “Input”

2. GPI I/O Output mode -Tally signal is sent by Keyboard Controller
 - a. Connect camera with keyboard by standard RS-422 control cable;
 - b. Access to KEYBOARD SETTING > GPI I/O > Setting, and change it to Output mode, then Exit to home directly;
 - c. After done above operation, we can switch to different camera by keyboard, for example, if we switch to camera 1 on keyboard, it will send tally signal to camera 1 via standard RS-422 control cable, so camera 1 tally light will turn on, and keyboard can control camera 1 pan and zoom;
 - d. If switch to camera 2 on keyboard, then camera 2 tally light will on and camera 1 tally light will off;

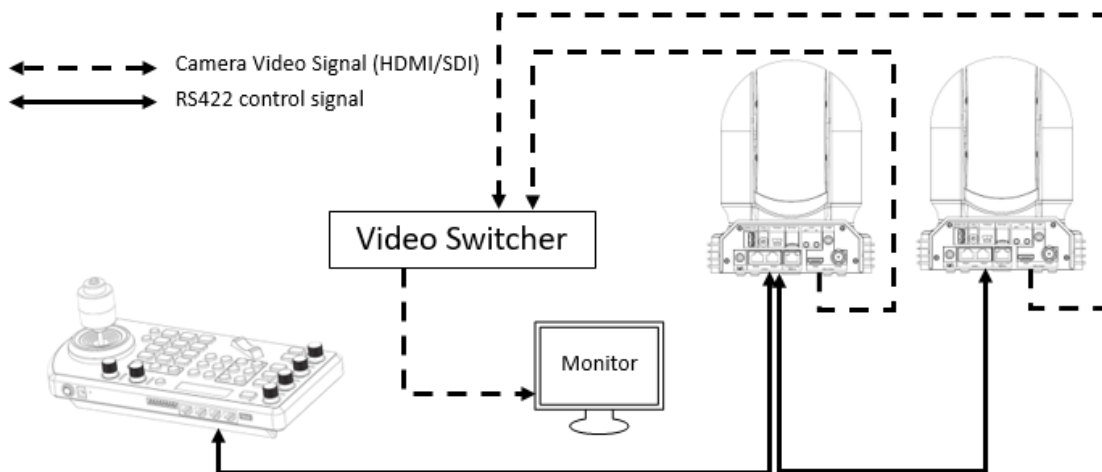

Tally Light GPI Connection – Using RS422 VISCA Control Protocol

Diagram when GPI is select “Output”

GPI connection with VISCA OVER IP control connection

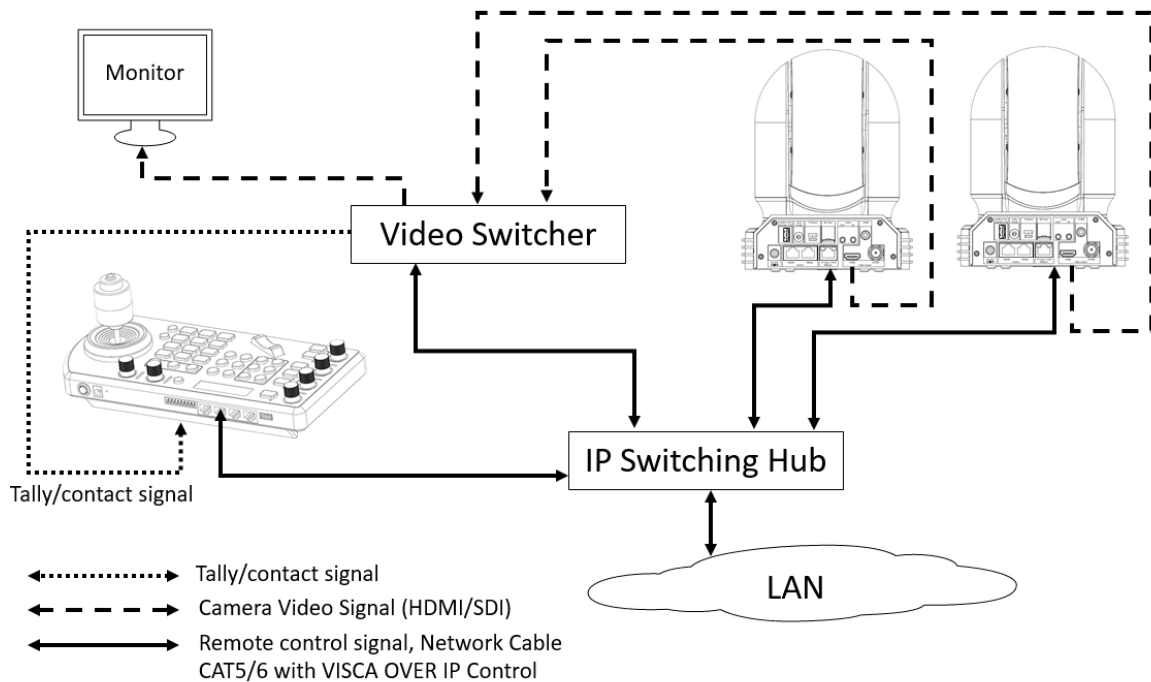

Tally Light GPI Connection – Using VISCA OVER IP Control Protocol
– With Visca Over IP ready Camera

How to make the connection with BOLIN products

Please see the User Guide “BOLIN Camera and Keyboard Controller Connection” that you can download it at www.bolintechnology.com product pages.

Control Mode - Video Router Switch Cross-Protocol Mix Control (Video Router Switch Mode)

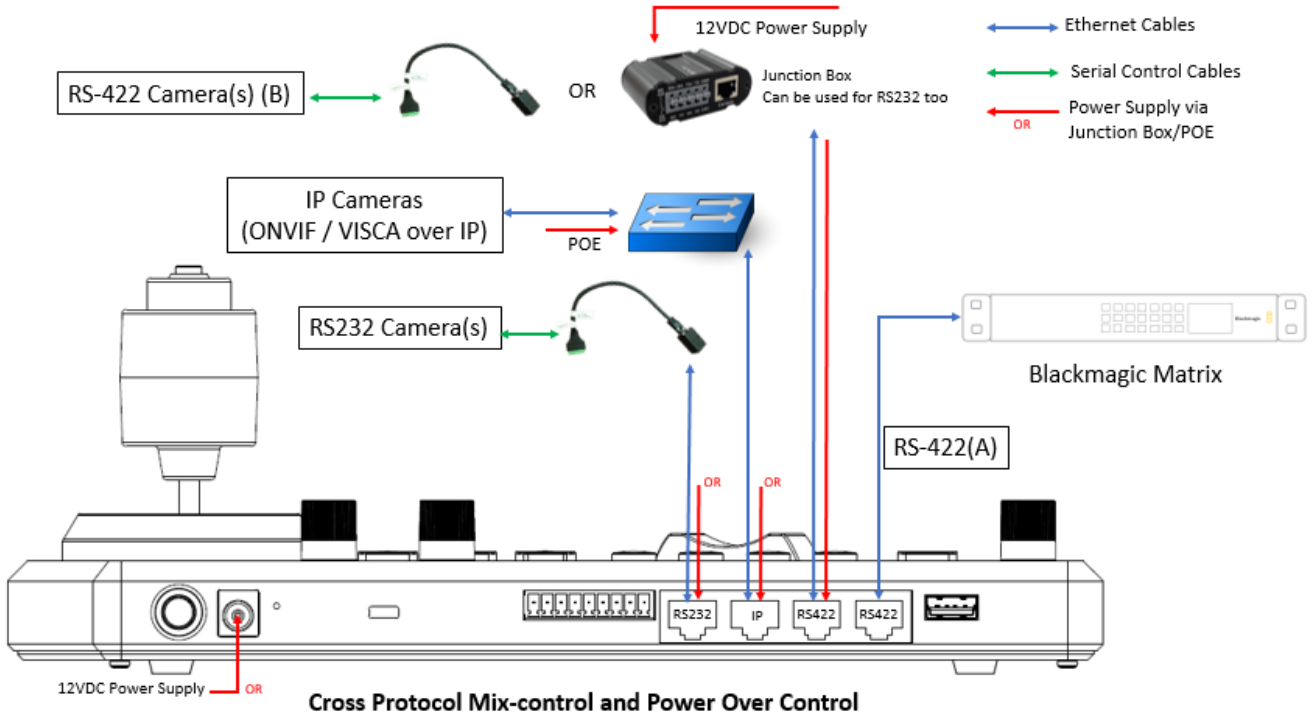
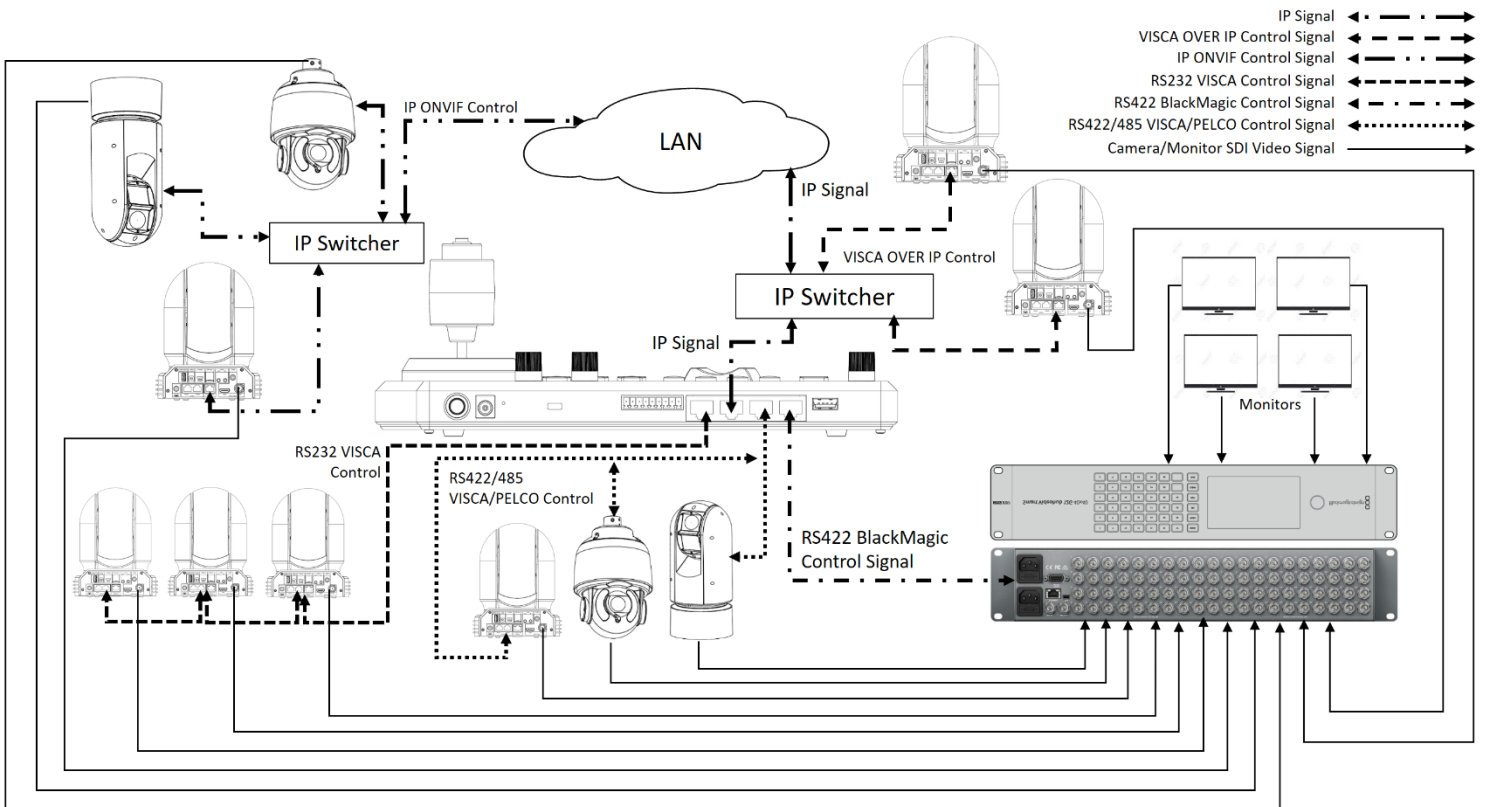

Figure 3 - When the junction box is powered, it will provide power to the keyboard via any port that it is connected to --RS232, IP, RS422(B). **No additional power supply is required for the keyboard a powered junction box is being used.**



Keyboard Control in Video Router Switch Mode – Compatible with Black Magic Smart Videohub

In Video Router Switch control mode, it allows you to use keyboard CAM key and MON key to select any one of the cameras displaying on any one of the monitors within the video router/matrix system with PTZ camera control. After the PTZ camera is switched on the monitor, you can right away control the PTZ camera without any extra keyboard operation.

NOTE: Important

- *In order to switch camera on the video router with PTZ camera control together, you need to set the camera ID on the keyboard as the same as camera input number on the video router.*
- *For example, on the keyboard, there is the camera 3 (serial control) and camera 12(Visca-Over-IP control). This camera 3's SDI signal needs to go into camera input 3 on the video router, camera 12's SDI signal needs to go into camera input 12 on the video router.*

Current compatible video router supported:

- Black Magic Design-Smart VideoHub
- To Be Continue Added

Go to Keyboard Setting to select Video Router Mode in Control Mode.

- After select the Video Router Mode, RS422 Port A will be assigned for Video Router control only, can not be used for camera switching.
- RS422 Port B will be assigned for camera switch, so Group B (Button at bottom next to Number Pad) will be activated by default for camera switching.

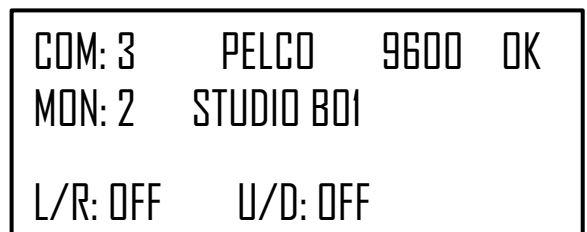

Connect to the keyboard RS422 (A) port to a video router/matrix that supports RS422 control, such as Blackmagic Smart VideoHub.

- How to connect the RS422 control port A on the keyboard to video router, or how to make the RS422 control connector for the video router, please refer to the useguide of the video router.

This keyboard integrated Blackmagic Matrix Switching Protocol, with Video Router Switch mode selected, the keyboard sends control command to deliver different camera signal to different monitor that connected with the video router/matrix.

The home screen will display MON information after Control Mode being set to Video Router Switch mode. MON: 2 means the selected camera 3 image is delivered to the monitor 2 that connected with the router/matrix, press the keyboard number 2 button and then press MON button, the selected camera image will be delivered to monitor 2.

NOTE:

- *In Video Router Switch mode, the RS422(A) port is only used for connecting video router/matrix, it is not available for camera PTZ control anymore. Only RS422(B) is for PTZ camera control.*
- *If you want to use RS422(A) back for camera PTZ control, please set the Control Mode back to PTZ Controller Mode in Keyboard Setting menu.*

IP Network Connection

Before accessing a keyboard controller IP web interface, you need to connect the keyboard to the PC/laptop directly with a network cable or via a network switch/router.

Login Preparation

- The keyboard controller is powered on and connected to the network switch
- The keyboard's IP address is located within the same subnet as the PC/laptop
- The PC/laptop is connected to the network switch
- The PC/laptop's IP address is located within the same subnet as the keyboard
- The PC/laptop is installed with Internet Explorer 11 (Only supported)

Logging in to the Web Interface

The default static IP address of the keyboard is 192.168.0.13, and the default subnet is 255.255.255.0

The following uses Internet Explorer 11 as an example to describe the login procedure.

1. Browser to the login page by entering correct IP address (e.g. <http://192.168.0.13>) of your keyboard in the IE 11 address bar;
2. Enter the user name as admin, and keep the password field empty (means leave the password blank, don't enter);



Introduction to the Web Interface

After login to the web interface, you will be located at *Upgrade* page, it is used to do IP firmware upgrade of the keyboard. User can check keyboard current IP firmware version on *Version* page.

The following steps will show you how to do IP firmware upgrade:

1. Click "*Browse...*" button and select the new IP firmware file, then click "*Upload*";
2. Find existing IP firmware version of the keyboard in the menu on keyboard, Setup>Keyboard Setting>Model Info.
 - a. If the IP firmware version showing **V1.x.x**, use the **.img file** to upgrade the keyboard.
 - b. If the IP firmware version showing **V2.x.x**, use the **.csf file** to upgrade the keyboard.
3. It takes around 30 seconds to upload the firmware file to keyboard;
4. It will pop-up tips that upload successful, then please click "*Upgrade*" button on the pop-up tips window to start IP firmware upgrade;
5. It will pop-up "Upgrading, don't operate...", upgrade takes 2-3 minutes;
6. After done, it will pop-up "Upgrade success, restarting...", few seconds later will turn back to the login page;
7. Wait for 1 minute, you will be able to login the IP web interface again.

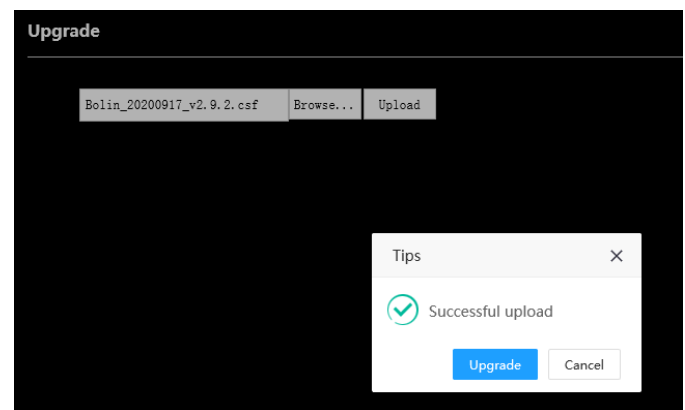
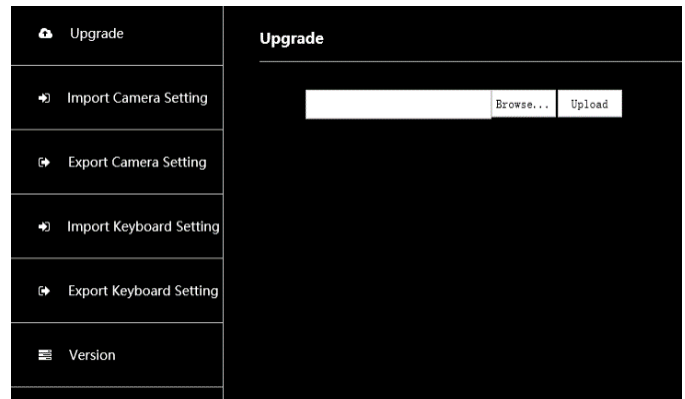

Configuration File Export & Import

When you have one keyboard completely setup with keyboard configuration and camera configuration, and you have more than one new keyboards added to the same system. This Configuration File Export & Import feature will help with you duplicating the keyboard settings to new keyboards.

Configuration file export & import function allows user to migrate the Camera Setting data and Keyboard Setting data that have been configured from one keyboard to another.

Note:

- Before you start keyboard configuration file export/import, the IP address fo the new keyboard has to be configured seperately. Configuration file export/import does not include IP address migration.

Export: (Camera Setting Data)

1. Login the Keyboard web interface. Via IE browser, use the IP address which you can get from the Keyboard Setting>IP Configuration. The user name is admin, password: No password, Keep the field empty.
2. After login, you will get the export & import list, the camera setting data and keyboard setting date need to be exported & imported separately.
3. Access to Export Camera Setting Data page, click Export button, it will start exporting. Please make sure the keyboard LED OSD is under home screen (not accessing to any setting menu).
4. During the processing of exporting, the keyboard LED screen will display the percentage of the exporting progress, please do not do any operation during the whole exporting progress.
5. After export the data, please save the CameraBackup / KeyboardBackup file in your local laptop/PC
6. Keyboard Setting Data exporting operation is same as above

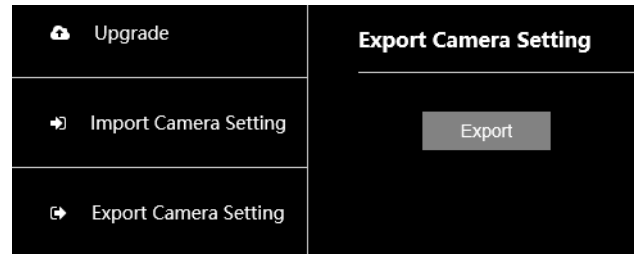
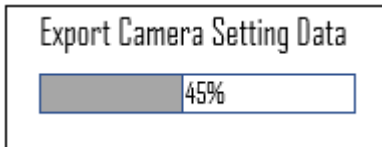
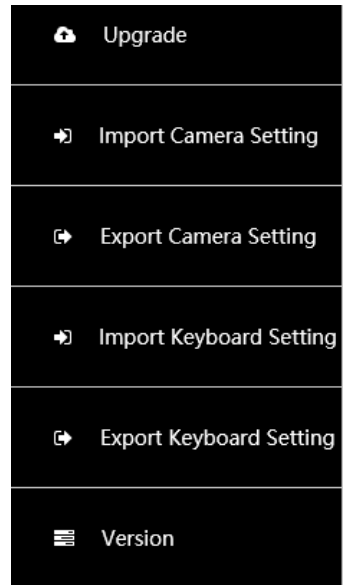

NOTE:

- The Export & Import function is only available while the keyboard is under home screen.

Import: (Camera Setting Data)

1. Setup IP configuration to the new keyboard and login the web interface.
2. Access to Import Camera Setting Data or Import Keyboard Setting Data page
3. Click Browser button to select the backup file, then click Import button to start importing. It will display the percentage of the importing progress on keyboard LCD screen.
4. After finishing importing the backup file, the new keyboard configuration will be the same as the original one, user doesn't have to set up the new keyboard from beginning.

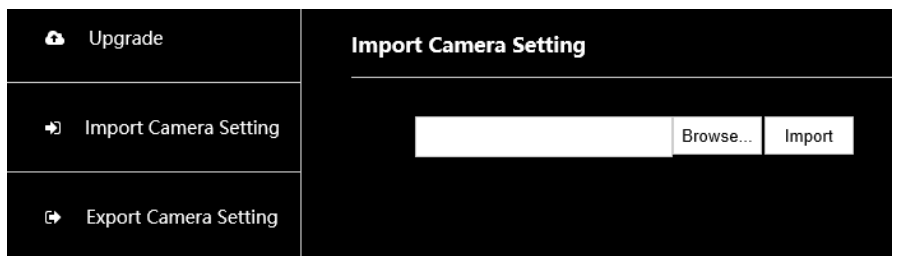

Keyboard Setting Tool

When you have a PTZ camera control system that has multiple cameras and multiple keyboards need to be set up, you don't have to make the configuration on each of the camera/controller, use this software tool to duplicate the configuration of the keyboard into multiple other keyboards.

You can use this Keyboard Setting Tool is to set up all the menu functions/configurations of the keyboard via software. A configuration file will be generated and can be exported, which user can use to import into other keyboards via IP web interface.

Keyboard Setting Tool allows user to configure the Keyboard Setting data and Camera Setting data.

1. Keyboard Setting

P/T SPEED	5	ZOOM SPEED	5
BUTTON LIGHT	2	JOYSTICK ZOOM	ON
F1	HOME POSITION	F2	P/T RESET
F3	POWER STANDBY	F4	MUTE
F5	PICTURE FREEZE	F6	IMAGE STABILIZER
CONTROL MODE	PTZ CONTROLLER	SETTING	Input
TALLY MODE	Normal	COMMAND SEL	Standard
CAMERA LINK	On	PORT	52381
PAYLOAD HEADER	On	PORT	52381

Export Import Restore

This page is used to configure the Keyboard Setting data, as followings:

- **P/T SPEED** – Match with keyboard P/T speed knob setting level, selectable from 1 to 9
- **ZOOM SPEED** – Match with Keyboard zoom speed knob setting level, selectable from 1 to 9
- **BUTTON LIGHT** – Adjust brightness of the keyboard button backlight, selectable from 0 to 2
- **JOYSTICK ZOOM** – OFF, ON
- **F1 - F6** – Assign Keys, selectable from wiper on, wiper off, home position, P/T reset, power standby, mute, picture freeze, image stabilizer, HL compensation, trace memory set, trace memory call, trace memory cancel, camera1 ~ camera 7 and None. (Subject to change or upgrade without notice)

NOTE: wiper on and wiper off function is used for SD500 and EX1000 series outdoor cameras.

- **CONTROL MODE** – Selectable from PTZ controller and video router switch

NOTE: In PTZ controller mode, RS422A interface connect an RS422 adapter to control up to 7 daisy-chained RS422 cameras. In video router switch mode, RS422A interface connect to video matrix, to control video switching via keyboard.

- **SETTING** – Tally GPI I/O mode setting, Input and Output mode
- **TALLY MODE** – Normal and Air mode
- **COMMAND SEL** – Standard and expand
- **CAMERA LINK** – ON, OFF

- **PORT** – 52381, 1259, User
- **PAYLOAD HEADER** – ON, OFF
- **PORT** – Adjustable when above port selected User mode.

Export – To export the above keyboard setting data, generate a configuration file and save it in the Keyboard Setting Tool folder, the configuration file name is “KeyboardInfoBackup”

Import – To import the keyboard setting configuration file

Restore – To restore the setting data to default.

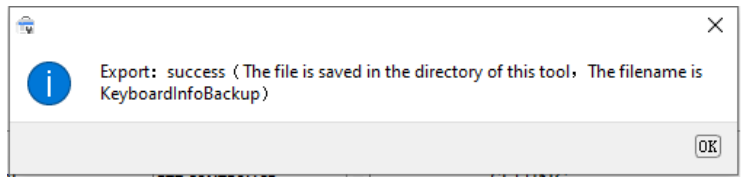

2. Camera Setting

This page is used to configure the Camera Setting data, the CAM number list includes total 255 cameras. User can select all to configure them together, or select one camera by check the selection box, to configure it indevidully. Here, select one camera to do configuration for example:

Check the selection box and click Edit button, you will get the camera setting page.

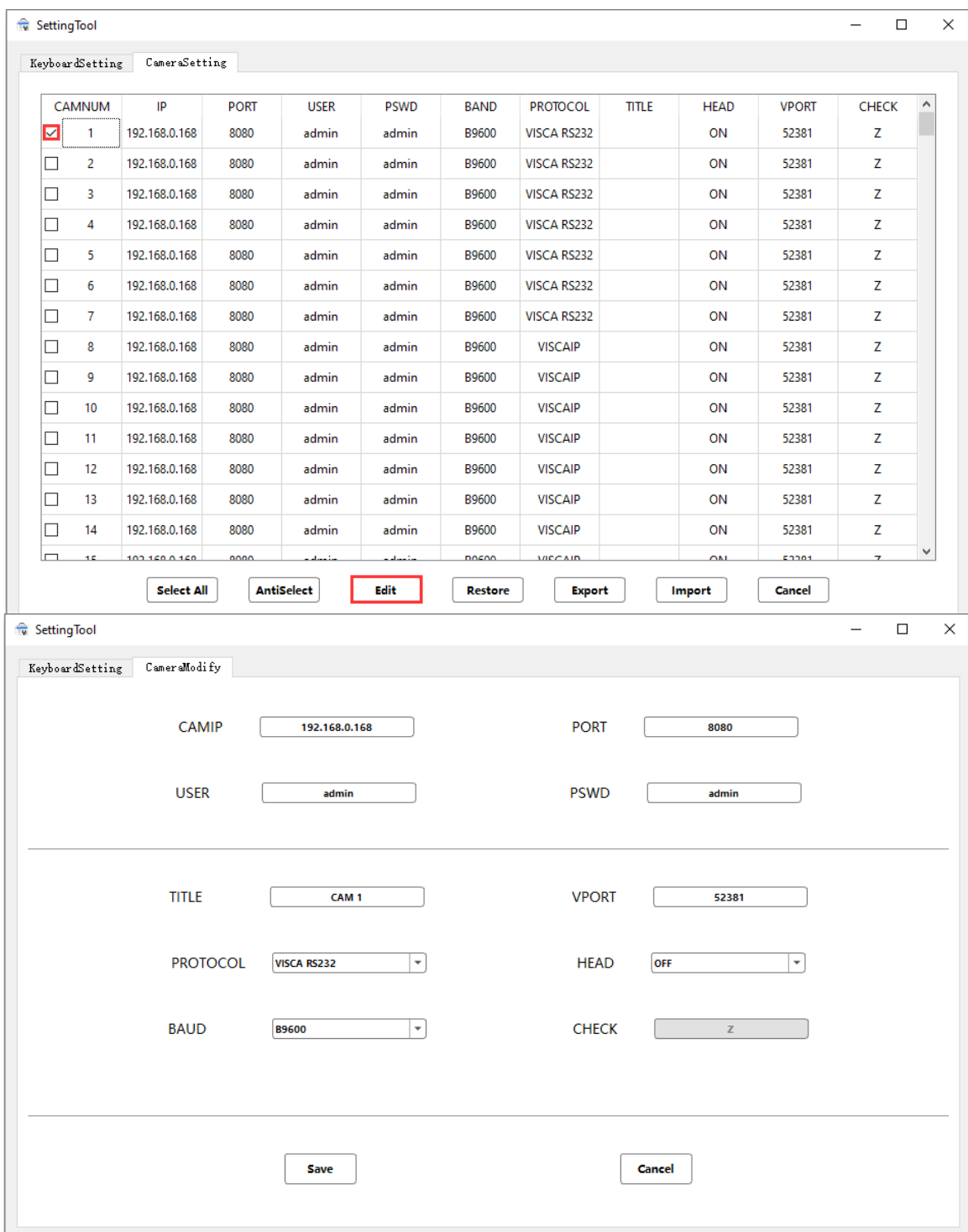

- **CAMIP** – IP address of the camera been selected
- **PORT** – Port for ONVIF protocol connection, 8080 by default
- **USER** – User name for this camera IP web interface login
- **PSWD** – Password for this camera IP web interface login
- **TITLE** – Camera title, it will be displayed on the keyboard LED screen
- **VPORT** – Visca IP port, 52381 by default
- **PROTOCOL** – Camera control protocol, selectable from VISCA RS232, VISCA RS422, PELCO-D, PELCO-P, ONVIF and VISCA IP
- **BAUD** – Camera control baud rate, it should match with the baud rate been set on the camera
- **CHECK** – The check code for communication between the MCU and the IP board

Save – Save the above settings and return to previous page

Cancel – Cancel the above settings and return to previous page

SelectAll – Select all of the cameras in CAMNUM list

AntiSelect – Cancel select all of the cameras in CAMNUM list

Export – To export the above Camera setting data, generate a configuration file and save it in the Keyboard Setting Tool folder, the configuration file name is “CameraBackup”

Import – To import the Camera setting configuration file

Restore – To restore the setting data to default.

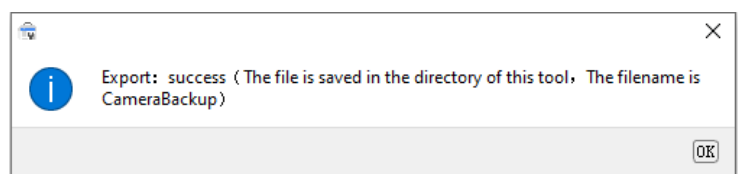

Keyboard Configuration

Interacting with the KBD-1010

Setup:

P/T Speed Dial:

- Rotate: Move Cursor
- Click: Select
- Long Press: Invert L/R (pan axis)
-

Zoom Speed Dial:

- Rotate: Select Value
- Click: Save
- Long Press: Invert U/D (Tilt axis)

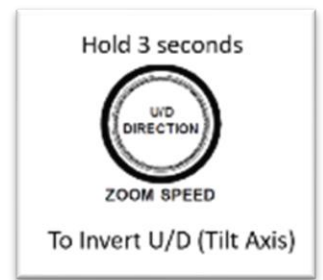
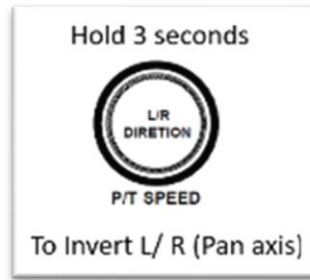

Setup button

Default Password: 0000

The password can be changed under
Setup > Keyboard Setting > Password
Setting
Opens Menu on LCD screen

The Setup button opens the setup menu on
the LCD screen

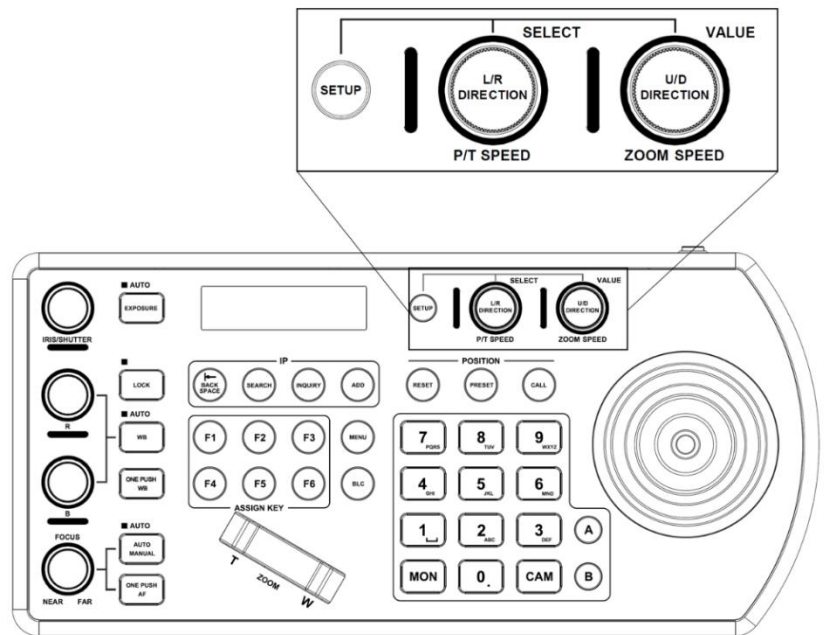

IP Setup

The IP address can be set to either **STATIC** or **DHCP**.

Main Setup Menu

```
CAMERA SETTING
>KEYBOARD SETTING
EXIT
```

Keyboard Setting Menu

```
>IP CONFIGURATION
BUTTON LIGHT
ASSIGNED KEY: F1
FACTORY DEFAULT
GPI I/O
PASSWORD SETTING
JOYSTICK ZOOM: ON
MODEL INFO
VISCA IP SETTING
CONTROL MODE
Exit
```

- If setting the IP address to DHCP, move the cursor to the Type field, and rotate the Zoom Speed dial to change the value to DHCP. Click the Zoom Speed dial to save

- If setting the IP address to a STATIC address, ensure that the Type field shows STATIC, and then rotate the P/T Speed dial to move the cursor between the IP address octets. Move the cursor to each octet and use the alphanumeric keypad to enter its value. Rotate the P/T Speed dial to move to the next octet and repeat until all IP address octets are set to the desired values.
- Click the Zoom Speed dial to save
- Edit the Subnet Mask and Gateway as necessary to communicate on your network
- Click the Zoom Speed dial to save
- Exit this menu

Keyboard Setting Menu

```

>IP CONFIGURATION
  BUTTON LIGHT
  ASSIGNED KEY: F1
  FACTORY DEFAULT
  GPI I/O
  PASSWORD SETTING
  JOYSTICK ZOOM: ON
  MODEL INFO
  VISCA IP SETTING
  CONTROL MODE
  Exit
  
```

IP Configuration Menu

```

>Type: STATIC
IP Address
192. >168. >0. >100
Subnet Mask:
255. 255. 255. 0
Gateway:
192. 168. 0. 1
Exit
  
```

Button Light

The Button Light value affects the brightness of the button backlight

- Rotate the Zoom Speed dial to adjust the value
- Click the Zoom Speed Dial to save
- Exit this menu

Keyboard Setting Menu

```

IP CONFIGURATION
>BUTTON LIGHT
  ASSIGNED KEY: F1
  FACTORY DEFAULT
  GPI I/O
  PASSWORD SETTING
  JOYSTICK ZOOM: ON
  MODEL INFO
  VISCA IP SETTING
  CONTROL MODE
  Exit
  
```

Button Light Menu

```

>Level: 0
Exit
  
```

Assign keys

Assigned keys can be configured as shortcuts to activate camera functions

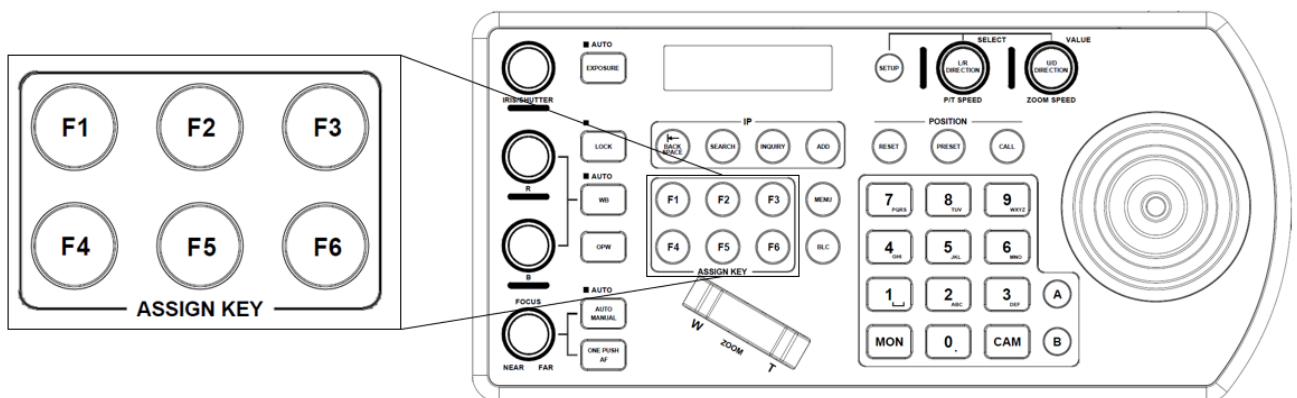

- From the keyboard Setup Menu, move the cursor to the ASSIGNED KEY field
- Rotate the Zoom Speed dial to select which Assigned key to configure
- Click the P/T Speed button to apply the function to the assign key
- Assigned key can be assigned to camera features from following:

```

IP CONFIGURATION
BUTTON LIGHT
>ASSIGNED KEY: F1
  FACTORY DEFAULT
  FACTORY DEFAULT
  GPI I/O
  PASSWORD SETTING
  JOYSTICK ZOOM: ON
  MODEL INFO
  VISCA IP SETTING
  CONTROL MODE
  Exit
  
```

```

>HOME POSITION
Exit
  
```

- **WIPER ON** – One button to turn on the wiper function
 - **WIPER OFF** – One button to turn off the wiper function
 - **HOME POSITION** –Command the selected camera to activate its ‘Home’ preset
 - **P/T RESET** – Reset the selected camera
 - **POWER STANDBY** – Power off /on the selected camera
 - **MUTE** – Mute the audio from the selected camera
 - **PICTURE FREEZE** – Freeze the image of the selected camera
 - **IMAGE STABILIZER** – Turn on/off image stabilizer of the selected camera
 - **HL COMPENSATION** – Turn on/off highlight compensation of the selected camera
 - **TRACE MEMORY SET** – To set and record trace memory
 - **TRACE MEMORY CALL** – To call the recorded trace memory
 - **TRACE MEMORY CANCEL** – To delete the recorded trace memory
 - **CAMERA 1~CAMERA 7** – Select the camera with the corresponding CAM ID
 - **NONE** – No function will be assigned to the key
- Exit

NOTE:

Wiper on and wiper off function is used for Bolin SD500 series or other outdoor PTZ camera that has wiper.

How to use Assign Keys to operate the Trace Memory function

1. Assign Trace Memory function to the Assign Key
 - Access to KEYBOARD SETTING>ASSIGN KEY menu;
 - Select F1(rotate the Zoom Speed knob to select Assign Key F1~F6), and press P/T Speed knob;
 - Rotate the Zoom Speed knob to select Trace Memory Set, Trace Memory Call or Trace Memory Cancel;
 - Exit the setting menu back to HOME screen;
2. Trace Memory Set
 - Press Assign Key F1 button, you will get the Trace Memory setting menu;
 - Rotate Zoom Speed knob to select TRACE NO (1~4 selectable);
 - Pan/tilt/zoom control camera move to the start point;
 - Rotate P/T Speed knob to roll cursor to START RECORDING, and press P/T Speed knob to access;
 - Up to 100 pan/tilt/zoom commands can be recorded for up to 60 seconds;
 - Perform the pan/tile/zoom operations you want to record, during recording, elapsed commands number increases in increments of 1 when keyboard execute a command;
 - Rotate P/T Speed knob to roll cursor to FINISH RECORDING, and press P/T Speed knob to stop recording;
 - Move the cursor to PLAY TIMES, can be set to ONCE or UMLIMIT;
3. Trace Memory Call
 - Assign Trace Memory Call to Assign Key F2 (or others Assign Key);
 - Select the Trace Memory NO which you want to playback by press the number button 1~4;
 - For example, to call Trace Memory NO 1, press number button “1” and then press Assign Key “F2”;
 - Camera will run Trace Memory 1 as recorded;
4. Trace Memory Cancel
 - Assign Trace Memory Cancel to Assign Key F3 (or others Assign Key);
 - Select the Trace Memory NO which you want to delete by press the number button 1~4;
 - For example, to cancel Trace Memory NO 1, press number button “1” and then press Assign Key F3;
 - Trace Memory 1 will be deleted.

NOTE: Keyboard should in HOME screen while operate Trace Memory function.

```

MOVE TO START POINT
>TRACE NO 1
START RECORDING
EXIT

```

```

RECORDING... 0/100
>FINISH RECORDING
PLAY TIMES: ONCE
EXIT

```

Factory Default

Clear all keyboard settings, and restore factory default

- From the Keyboard Setup Menu, select FACTORY DEFAULT
- Select Yes

NOTE: DO NOT move the Joystick nor the Zooming Seesaw and leave them at original position while the FACTORY DEFAULT is processing.

Keyboard Setting Menu

```

IP CONFIGURATION
BUTTON LIGHT
ASSIGNED KEY: F1
>FACTORY DEFAULT
GPI I/O
PASSWORD SETTING
JOYSTICK ZOOM: ON
MODEL INFO
VISCA IP SETTING
CONTROL MODE
Exit
    
```

Factory Default

```

>Yes?
No?
    
```

Tally - GPI I/O

GPI I/O Menu is used to configure the Tally settings

- Setting:
 - Input - Sets the control signal direction of the GPI I/O connector to INPUT. In this case, connect a tally control input signal to the connector
 - Output - Sets the control signal direction of the GPI I/O connector to OUTPUT. In this case, the connector functions as a contact output connector which outputs the camera number of the target camera.

Keyboard Setting Menu

```

IP CONFIGURATION
BUTTON LIGHT
ASSIGNED KEY: F1
FACTORY DEFAULT
>GPI I/O
PASSWORD SETTING
JOYSTICK ZOOM: ON
MODEL INFO
VISCA IP SETTING
CONTROL MODE
Exit
    
```

Tally Setting Menu

```

>Setting: Input
Tally Mode: Normal
Command Sel: Standard
Camera Link: On
Exit
    
```

- Tally Mode
 - Normal - Displays the tally input lamp corresponding to the number of the camera with tally input ON, and automatically selects the camera as the target camera.
 - NORMAL TALLY mode: The following actions are performed for the number that is input from the TALLY/ CONTACT connector only while receiving the commands.
 - The selected camera switches to the camera matching the number of the command from the TALLY/CONTACT connector.
 - When the selected camera number matches that of the command from the TALLY/ CONTACT connector: The selected camera is not switched and can continue to be operated.
 - When the selected camera does not receive its own number command from the TALLY/CONTACT connector: The selected camera switches to the camera whose number matches that of the command from the TALLY/CONTACT connector.
 - If two or more numbers are received from the TALLY/ CONTACT connector, the camera with the smallest number is selected. You can operate the selected camera after returning the joystick to the neutral position. (If you switch cameras and the camera group number changes, the GROUP/ POSITION button lights up for about 1 second.) • The selected CAMERA button will flash in red and yellow alternately.
 - If two or more numbers are received from the TALLY/ CONTACT connector, CAMERA buttons which are not selected will light in red. You can select a camera by pressing its respective CAMERA button (lit in red).
 - The tally lamp of the camera receiving a command from the TALLY/CONTACT connector lights. *
 - On Air - Displays the tally input lamp corresponding to the number of the camera with tally input ON.
 - ON AIR TALLY mode: The following actions are performed for the number that is input from the TALLY/ CONTACT connector only while receiving the commands.
 - The corresponding CAMERA button lights in red.

- A camera can be selected arbitrarily. Selecting a CAMERA button lit in red will make it flash in red and yellow alternately.
- The tally lamp of the camera receiving a command from the TALLY/CONTACT connector lights. *
- Command Select
 - Standard - Sets the input/output method to STANDARD method. The camera numbers and input/output pin numbers have a 1:1 correspondence.
 - If the unit and cameras are connected by serial connection, cameras 1 to 7 correspond to input/outputs 1 to 7.
 - If the unit and cameras are connected by LAN connection, cameras 1 to 10 in group 1 correspond to input/outputs 1 to 10.
 - Expand - Handles camera numbers as binary numbers.
 - Tally input numbers 8 and higher in a serial connection are ignored. In this case, the response is equivalent to no input.
 - Numbers in a LAN connection, corresponding to cameras 1 to 10 in groups 1 to 10, are handled as the numbers 1 to 100. Tally input numbers 101 and higher are ignored. In this case, the response is equivalent to no input.
- Camera Link - Turns tally lamp control on/off. The tally lamp control operation varies depending on the combination of the SETTING and CAMERA LINK settings.

Password Setting

- Old Password: Enter the current password
- New Password: Enter the password you would like to set
- Confirm: Enter the new password again to confirm
- Save: Select this to apply the password. “OK” will appear, confirming that the new password has been applied

Keyboard Setting Menu

```

IP CONFIGURATION
BUTTON LIGHT
ASSIGNED KEY: F1
FACTORY DEFAULT
GPI I/O
>PASSWORD SETTING
JOYSTICK ZOOM: ON
MODEL INFO
VISCA IP SETTING
CONTROL MODE
Exit
  
```

Password Setting Menu

```

>Old Password:
New Password
Confirm:
Save                               Exit
  
```

Joystick Zoom Setting

The joystick ring can control the camera’s zoom. This can be toggled under Setup/ Joystick Zoom.

This setting can be changed by rotating the Zoom Speed knob while the setting is selected

Click the Zoom Speed knob to save this setting if changed

If this setting is set to “OFF”, the Zoom Seesaw will remain active and can be used to control zoom

Keyboard Setting Menu

```

IP CONFIGURATION
BUTTON LIGHT
ASSIGNED KEY: F1
FACTORY DEFAULT
GPI I/O
PASSWORD SETTING
>JOYSTICK ZOOM: ON
MODEL INFO
VISCA IP SETTING
CONTROL MODE
Exit
  
```

Model Info

The Model info screen contains the current IP address and Firmware Version and IP Firmware Version of the unit

Keyboard Setting Menu

```
IP CONFIGURATION
BUTTON LIGHT
ASSIGNED KEY: F1
FACTORY DEFAULT
GPI I/O
PASSWORD SETTING
JOYSTICK ZOOM: ON
>MODEL INFO
VISCA IP SETTING
CONTROL MODE
Exit
```

Model Info Menu

```
>IP Address:
192.>168.>0.>100
FW Version: X.X.X
IP V X.X.X.
Exit
```

Visca over IP

This menu is used to configure Visca over IP.

Payload Header:

- A set of data carried with Visca-Over-IP protocol for camera compatibility identification. Some Visca-Over-IP cameras don't have it.
- The camera maker that has the Payload Header: SONY, BOLIN. For the cameras from these makers, Set it ON
- For the cameras from other makers, Set it OFF. Or consult the camera provider.

Port: The control port for Visca over IP.

- By default, is 52381.
- Camera maker SONY, BOLIN use port 52381.
- Other camera makers may use port 1259.
- USER, you can set the port that your camera is using.
- Please consult your camera provider for port information.

This keyboard supports any brand of Visca Over IP cameras in a same system.

If you have Visca-Over-IP cameras from more than one different camera makers, you may have to set the camera port differently. Go to camera setting, you can set Visca-Over-IP camera port individually.

NOTE:

Once the Visca-Over-IP configuration is set in this section, the Visca-Over-IP configuration data will be applied to all Visca-Over-IP cameras in the system.

Keyboard Setting Menu

```
IP CONFIGURATION
BUTTON LIGHT
ASSIGNED KEY: F1
FACTORY DEFAULT
GPI I/O
PASSWORD SETTING
JOYSTICK ZOOM: ON
MODEL INFO
>VISCA IP SETTING
CONTROL MODE
Exit
```

Model Info Menu

```
>Payload Header: ON
Port: 52381
Exit
```

Control Mode

The Control Mode contains PTZ Controller mode and Video Router Switch mode

- PTZ Controller: the keyboard used as a standard PTZ camera controller that we use usually. In this mode, RS422 A&B port all use for camera PTZ control
- Video Router Switch: the keyboard used as a video switching controller as well as a standard controller. In this mode, RS422 A port is used for video switching control, RS422 B port is used for PTZ camera control

Keyboard Setting Menu

```
IP CONFIGURATION
BUTTON LIGHT
ASSIGNED KEY: F1
FACTORY DEFAULT
GPI I/O
PASSWORD SETTING
JOYSTICK ZOOM: ON
MODEL INFO
VISCA IP SETTING
>CONTROL MODE
Exit
```

Model Info Menu

```
CONTROL MODE
>PTZ CONTROLLER
Exit
```

```
CONTROL MODE
>VIDEO ROUTER SWITCH
Exit
```

How to assign camera

Manually adding cameras

The keyboard can store settings to control up to

- 255 cameras by RS485 PELCO protocol separately
- 7 cameras by VISCA protocol via RS422 group A separately
- 7 cameras by VISCA protocol via RS422 group B separately
- 255 cameras by IP ONVIF protocol separately
- 255 cameras by VISCA-Over-IP protocol separately
- Total 255 cameras by cross protocol mix-controlling.

With the cursor on the Camera Selection, use the Zoom Speed dial to select which camera slot to assign a camera. Each camera can be configured to be controlled using any of the following protocols:

- VISCA
- PELCO-D
- PELCO-P
- ONVIF
- VISCAIP (VISCA over IP)
- CGI*

If VISCA, PELCO-D, or PELCO-P are selected as the protocol, the Baud Rate Setting screen will appear. Use the Zoom Speed dial to set the baud rate. Click the Zoom Speed dial to save, and then exit this menu.

After the camera is added, press the number of the camera ID, for example: 1, and then press the button CAM, the camera will be selected. On the LED display, this information shows the status of the camera.

OK shown at the right upper corner means the serial control is connected, and the communication is in place correctly. Ready to control.

Main Setup Menu

```
>CAMERA SETTING
KEYBOARD SETTING
EXIT
```

Camera Setting Menu

```
>CAM001
Title: -
Protocol: VISCA
Exit
```

Camera Setting Menu

```
CAM001
Title: -
>Protocol: VISCA
Exit
```

Baud Rate Setting

```
>Baud Rate: 9600
Exit
```

```
CAM: 001  V-422  9600  OK
TITLE: ABCDE001
L/R: OFF  U/D: OFF  +
```

Adding an ONVIF camera to Keyboard

Adding manually from Local Area Network (LAN)

Selecting ONVIF as the protocol and clicking the P/T Speed dial will cause the ONVIF Camera Setup menu to appear

- Must know about the IP address of the camera.
- The IP address of the camera has to be within the same subnet as the Keyboard
- Rotate the P/T Speed dial to move the cursor between the IP address octets. Move the cursor to each octet and use the alphanumeric keypad to enter its value. Rotate the P/T Speed dial to move to the next octet and repeat until all IP address octets are set to the desired values. Click the Zoom Speed dial to save

Camera Setting Menu

```
CAM001
Title: -
>Protocol: ONVIF
Exit
```

ONVIF Camera Setup Menu

```
>IP Address:
192.168. 0. 13
User Name
-admin
Password:
-admin
Port: 80
Exit
```

- Move the cursor to the User Name field, and use the alphanumeric keypad to enter the username (ESC button works as a backspace)
- Click the Zoom Speed button to save
- Move the cursor to the password field and use the alphanumeric keypad to enter the password (ESC button works as a backspace)
- Click the Zoom Speed button to save
- Move the cursor to the Port field
- If the camera is configured to communicate on a field other than port 80, change the port number using the alphanumeric keypad (ESC button works as a backspace)
- Exit this menu

Scanning Local Area Network (LAN) for available ONVIF cameras

Cameras can be detected on the network and added to the keyboard to be controlled

- Press the Search button to bring up the Auto Search menu
- Move the cursor to ONVIF-IP
- Select Yes to start the search
- A list of discovered cameras will appear showing the cameras that have been discovered. Scroll through the discovered cameras using the Zoom Speed dial
- To add a camera to be controlled by the KBD-1010, press the ADD button
- With the cursor on CAM ID, Assign the camera to a CAM ID by rotating the Zoom Speed dial
- Click the Zoom Speed dial to save
- Move the cursor to the Title, and use the alphanumeric keypad to give the camera a title
- Click the Zoom Speed dial to save
- Enter the username for the camera
- Click the Zoom Speed dial to save
- Enter the password for the camera
- Click the Zoom Speed dial to save
- Exit this menu

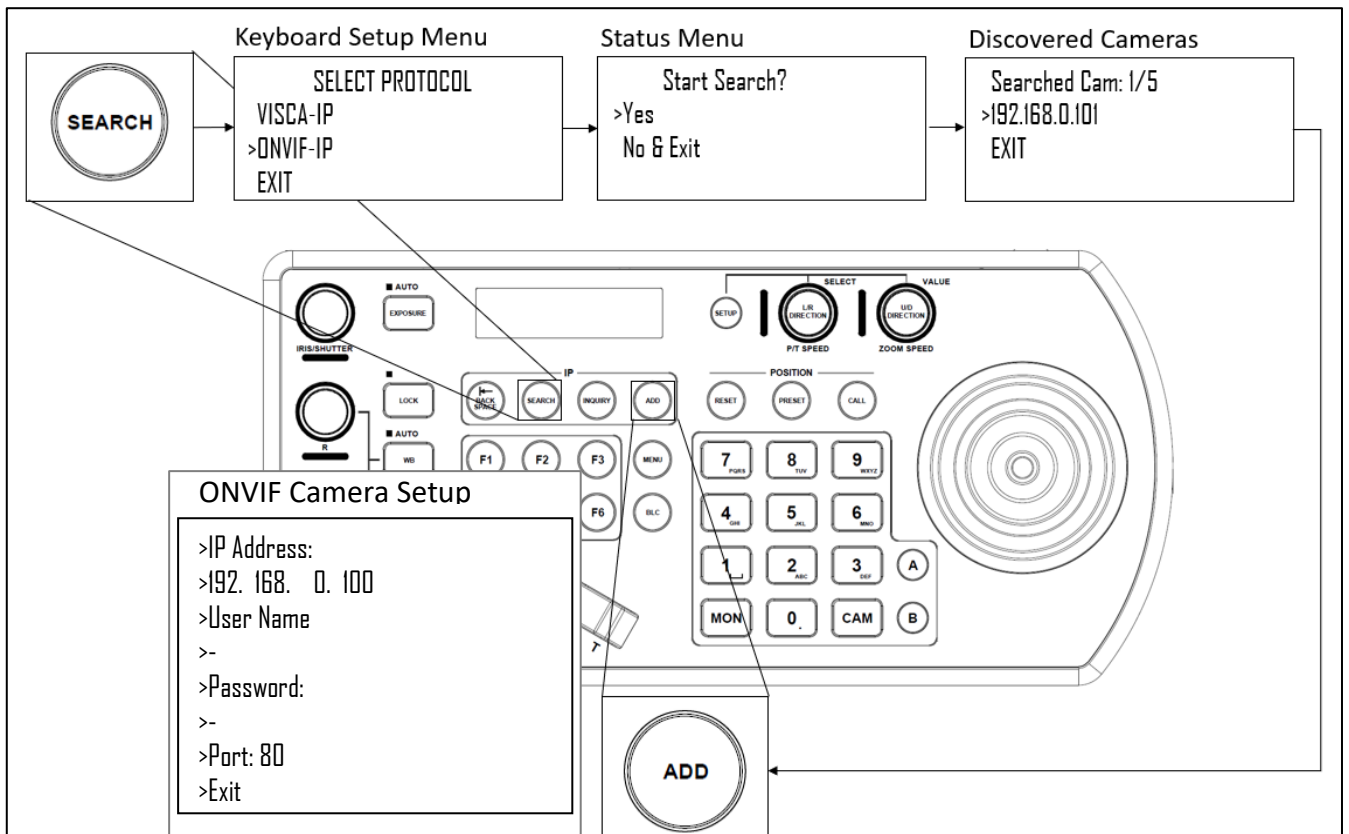

Repeat this process for each discovered camera that you wish to add to the KBD-1010

Adding ONVIF cameras to be controlled via WAN

1. At Camera Location:

- For commands to flow from outside the network in to a camera, ports must be opened
- Contact the network administrator at the camera location to create a port-forwarding rule in the router allowing commands to flow through the necessary ports using these values:
 - Source/ external port: **80 (default)**
 - Destination / internal port: **80 (default)**
 - IP Address: **IP Address of the camera**
 - Protocol: **Both (TCP and UDP)**

2. At Keyboard location:

- Set the keyboard to DHCP
- Contact the network administrator at the Keyboard location to create a port-forwarding rule in the router allowing commands to flow through the necessary ports using these values:
 - Source/ external port: **80 (default)**
 - Destination / internal port: **80 (default)**
 - IP Address: **IP Address of the keyboard**
 - Protocol: **Both (TCP and UDP)**
- Within the Setup menu of the KBD-1010, add the ONVIF camera using the WAN IP of the camera location as the IP Address
- Click the P/T Speed dial to save
- Enter the username of the camera
- Click the P/T Speed dial to save
- Enter the password of the camera
- Click the P/T Speed dial to save

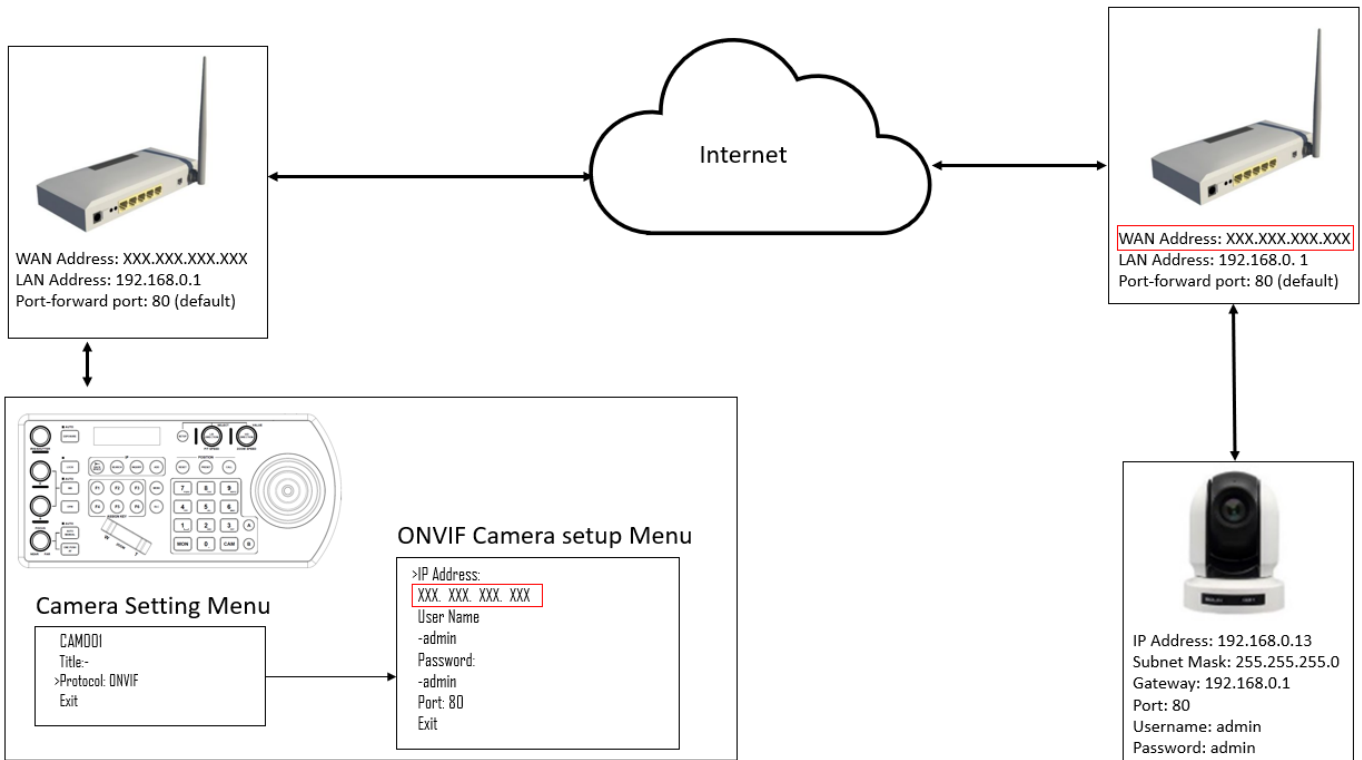

Adding a VISCA over IP camera to Keyboard

Adding manually from Local Area Network (LAN)

Selecting VISCAIP (VISCA over IP) as the protocol and clicking the P/T Speed dial will cause the VISCAIP configuration menu to appear

- Rotate the P/T Speed dial to move the cursor between the IP address octets. Move the cursor to each octet and use the alphanumeric keypad to enter its value. Rotate the P/T Speed dial to move to the next octet and repeat until all IP address octets are set to the desired values.

Camera Setting Menu

```
CAM001
Title: -
>Protocol: VISCAIP
Exit
```

VISCAIP Configuration Menu

```
>IP Address:
192.168. 0. 100
Payload Header: ON
Port: 52381
Exit
```

- Click the Zoom Speed dial to save
- Payload Header: A set of data carried with Visca-Over-IP protocol for camera compatibility identification. Some cameras don't have it.
- The camera maker that has the Payload Header: SONY, BOLIN. For the cameras from these makers, Set it ON
 - For the cameras from other makers, Set it OFF. Or consult the camera provider.
- Port: The control port for Visca over IP.
- By default, is 52381.
 - Camera maker SONY, BOLIN use port 52381.
 - Other camera makers may use port 1259.
 - USER, you can set the port that your camera is using.
 - Please consult your camera provider for port information.
 - Exit this menu

Repeat this process for each camera that you wish to control with the KBD-1010 keyboard.

Note:

This keyboard supports any brand of Visca Over IP cameras in a same system.

If you have Visca-Over-IP cameras from more than one camera makers, to may have to set the camera port differently for different cameras.

Scanning local network for available VISCA over IP cameras

- Press the Search button to bring up the Auto Search menu
- Move the cursor to VISCA-IP
- Select Yes to start the search
- A list of discovered cameras will appear showing the cameras that have been discovered. Scroll through the discovered cameras using the Zoom Speed dial
- To add a camera to be controlled by the KBD-1010, press the ADD button
- With the cursor on CAM ID, Assign the camera to a CAM ID by rotating the Zoom Speed dial
- Click the Zoom Speed dial to save
- Move the cursor to the Title, and use the alphanumeric keypad to give the camera a title
- Click the Zoom Speed dial to save

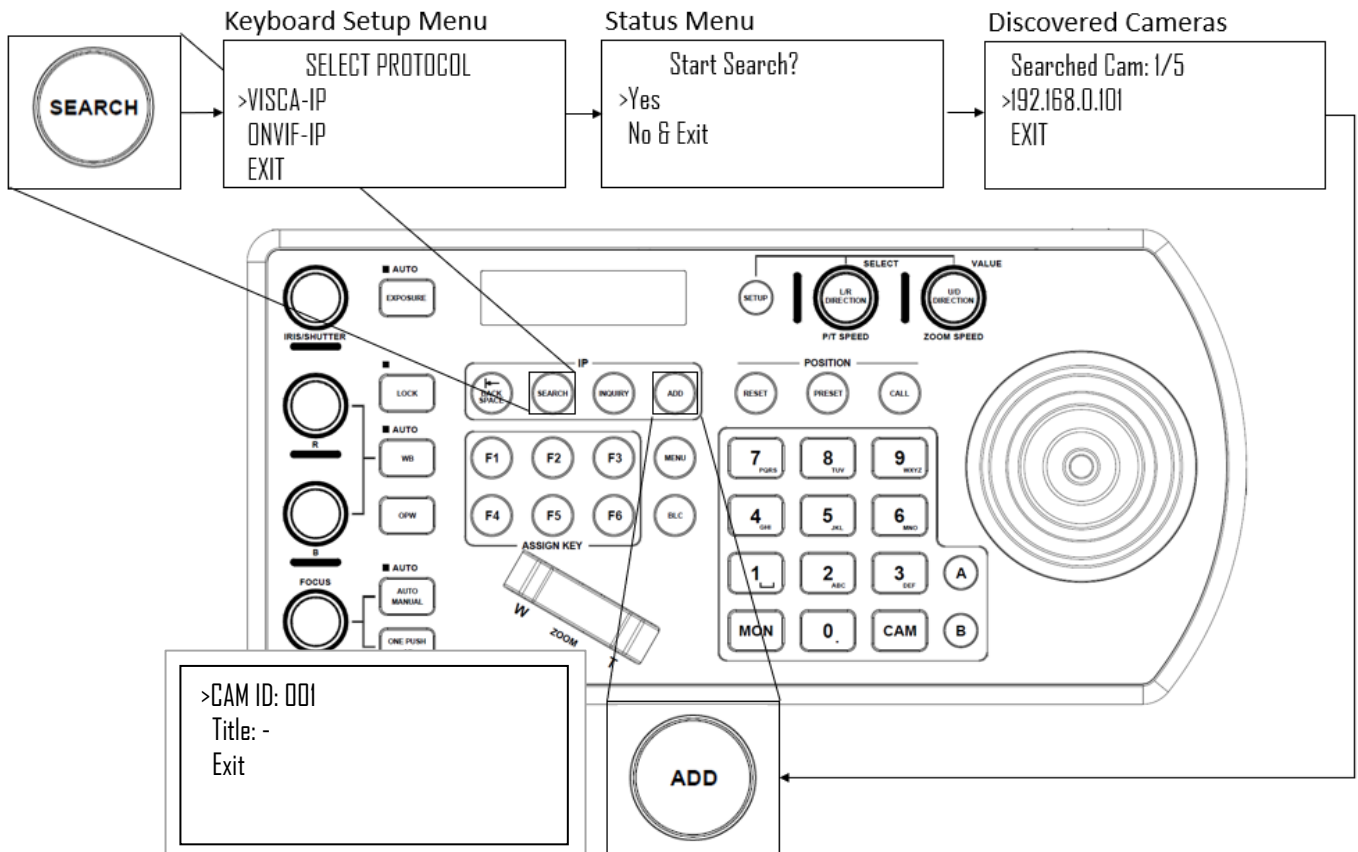

Repeat this process for each discovered camera that you wish to add to the KBD-1010

Adding VISCA over IP cameras to be controlled via WAN

3. At Camera Location:

- For commands to flow from outside the network in to a camera, ports must be opened
- Contact the network administrator at the camera location to create a port-forwarding rule in the router allowing commands to flow through the necessary ports using these values:
 - Source/ external port: **52381**
 - Destination / internal port: **52381**
 - IP Address: **IP Address of the camera**
 - Protocol: **Both (TCP and UDP)**

4. At Keyboard location:

- Set the keyboard to DHCP
- Contact the network administrator at the Keyboard location to create a port-forwarding rule in the router allowing commands to flow through the necessary ports using these values:
 - Source/ external port: **52381**
 - Destination / internal port: **52381**
 - IP Address: **IP Address of the keyboard**

- Protocol: **Both (TCP and UDP)**
- Within the Setup menu of the KBD-1010, add the VISCA over IP camera using the WAN IP of the camera location as the IP Address
- Click the P/T Speed dial to save

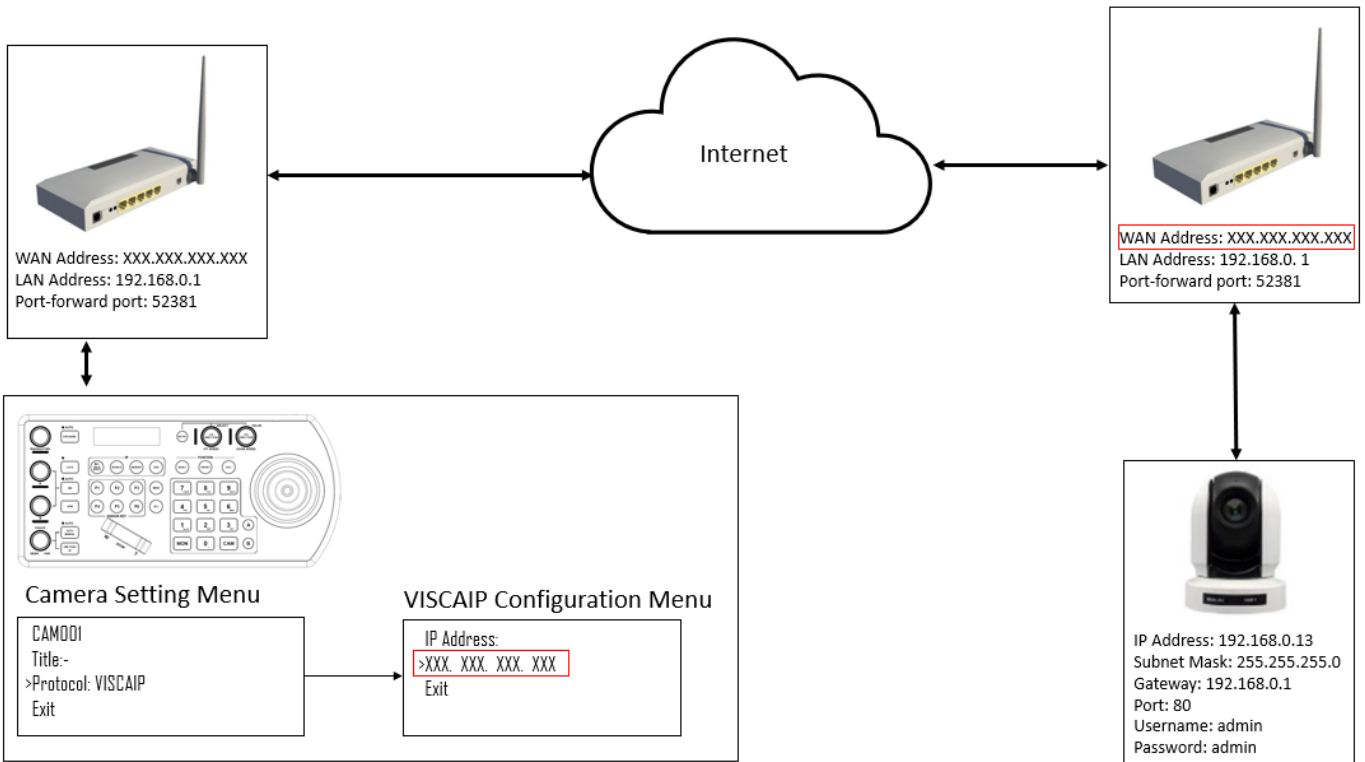

Operating Visca Over IP PTZ cameras

After the camera is added, press the number of the camera ID, for example: 3, and then press the button CAM, the camera will be selected. On the LED display, this information shows the status of the camera.

OK shown at the right upper corner means the Visca Over IP control is connected, and the communication is in place correctly. Ready to control.

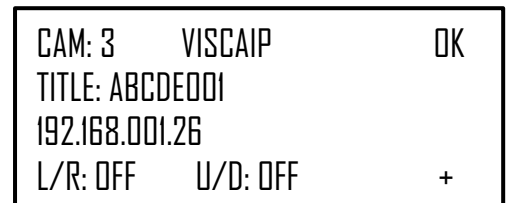

Interacting with Cameras

Dual RS422 button A/B

There are 2 RS422 ports on the back panel of the keyboard. Up to 7 cameras can be daisy chained off of each RS422 port. You can toggle between these by using the A and B buttons

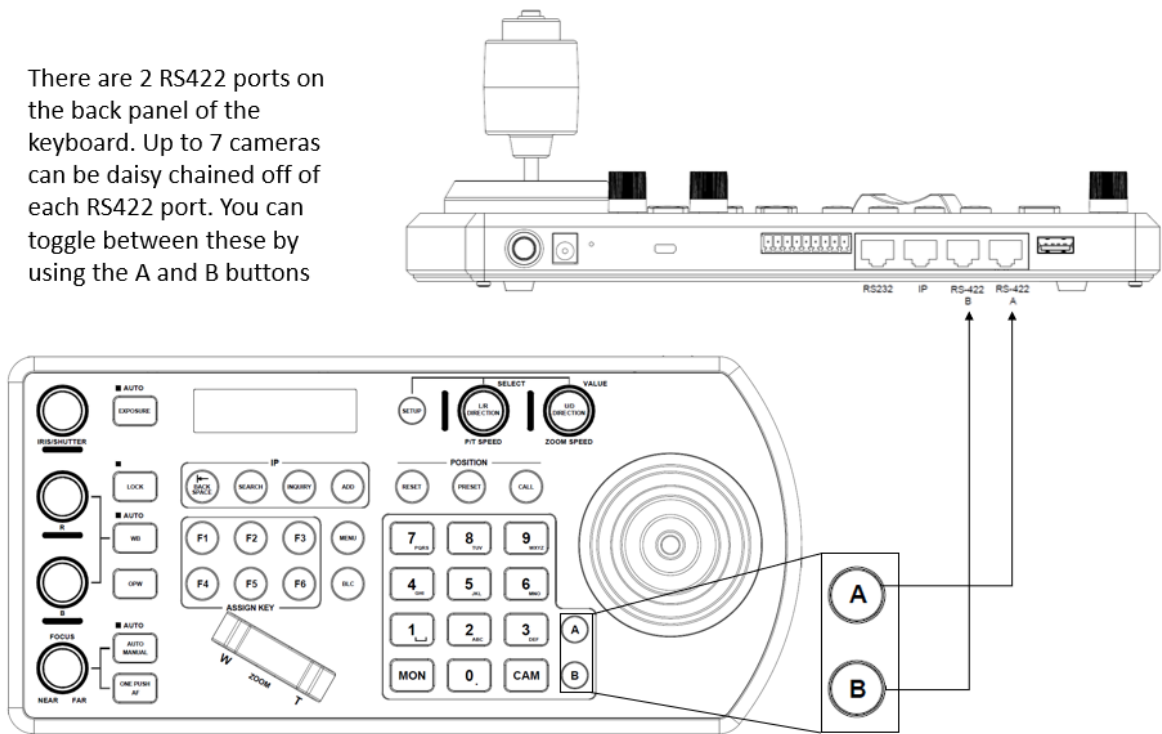

Options for calling camera

1. Use the keypad to call the camera by CAM ID
 - a. Enter the CAM ID on the keypad
 - b. Press CAM
2. Call the IP cameras by selecting from a list of available devices
 - a. Press the Inquiry button
 - b. Select a protocol
 - c. Scroll through the list using the Zoom Speed dial
 - d. Move the cursor to "Call", and click the P/T Speed dial

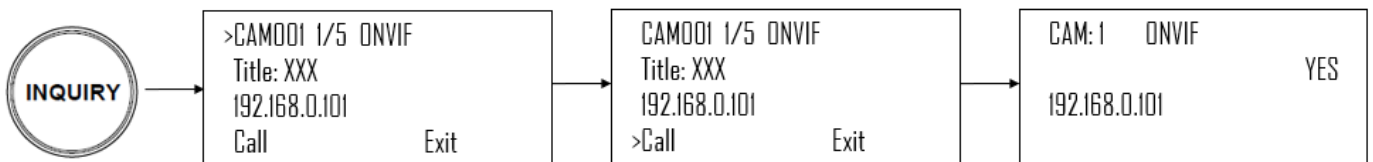
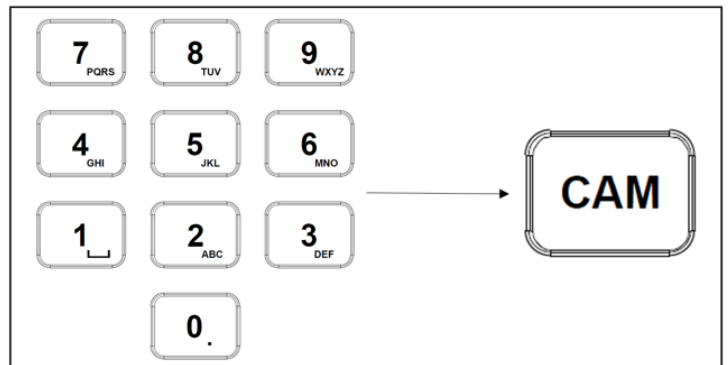

Controlling a Camera

Engaging the Camera OSD Menu for non-IP cameras

1. Press the Menu button on the keyboard to send a command to the camera to engage the OSD menu
2. Navigate the menu by using the joystick
 - a. Move up / down to navigate through menu options
 - b. Move the joystick to the right to send an “enter” command
 - c. Move up / down to adjust values
 - d. Move the joystick to the left to send an “exit” command

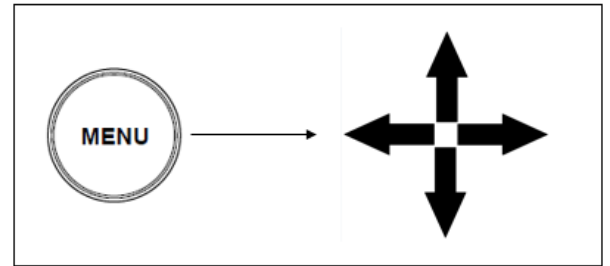

Engaging the Camera OSD Menu for PELCO-D or ONVIF-IP Cameras

1. On the alphanumeric keypad, call preset 95 to engage the menu (type 95, and then press the “Call” button)



Manual Movements

- Pan, Tilt, and Zoom movements can be executed simultaneously.
- The joystick can be used to pan / tilt the camera in any direction
- The joystick handle can be rotated to zoom in / zoom out
- When not in a menu, the P/T Speed and Zoom Speed dials control how fast the camera Pans, Tilts, and Zooms in response to commands from the keyboard
- The Zoom Seesaw can be engaged to zoom in / Zoom out

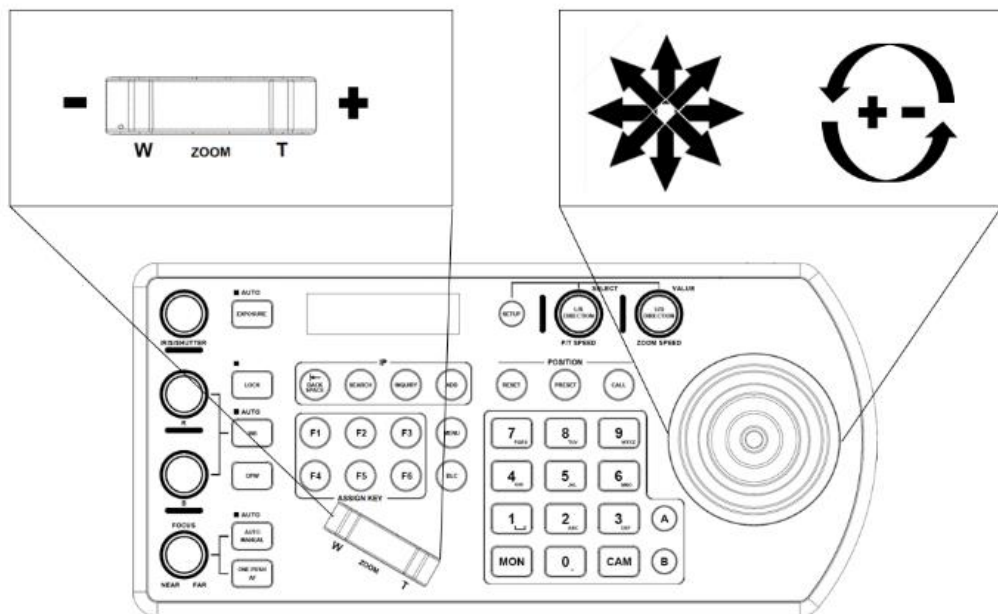

Setting and calling presets

Setting / creating presets:

1. Move the camera to the desired position
2. Enter the desired preset number on the alphanumeric keyboard, and then hold the Preset button for 3 seconds to save

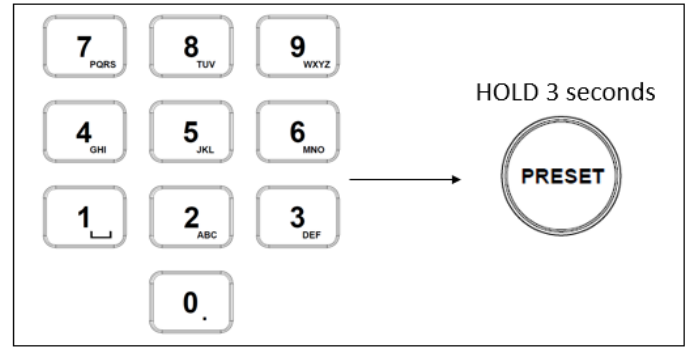

Calling presets:

1. Enter the desired preset number on the alphanumeric keypad
2. Press the Call button

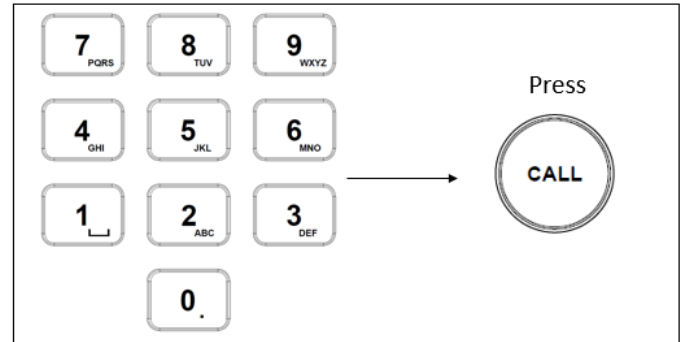

Resetting / Clearing presets:

1. Enter the number of the preset you would like to clear
2. Press the Reset button

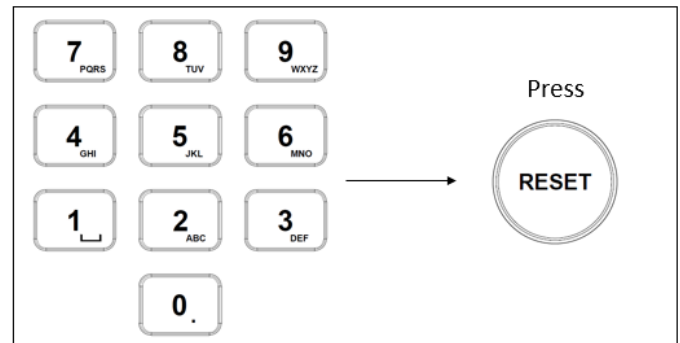

Adjusting image parameters

The following image parameters can be set/adjusted by using the Image Adjustment Panel

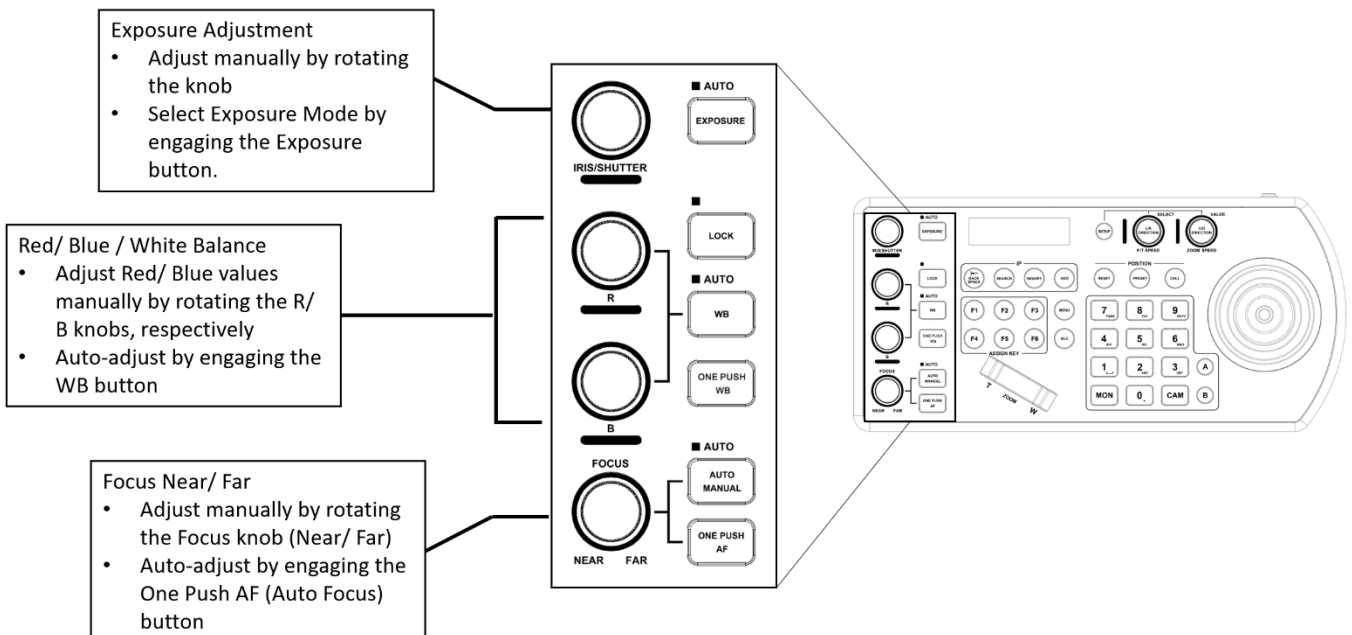

Toggle the Exposure between Auto Exposure, Iris priority, Shutter priority, Manual Iris Gain, Manual Shutter Gain, Black Level by pressing the EXPOSURE button.

Lock the Image Adjustment panel buttons by engaging the LOCK button

Engage One-Push-White Balance by pressing the OPW button

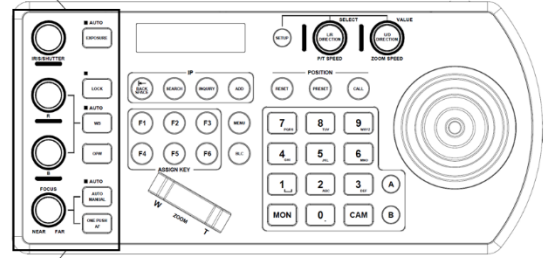
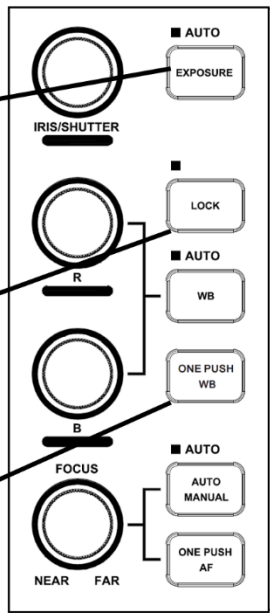

Firmware Upgrade

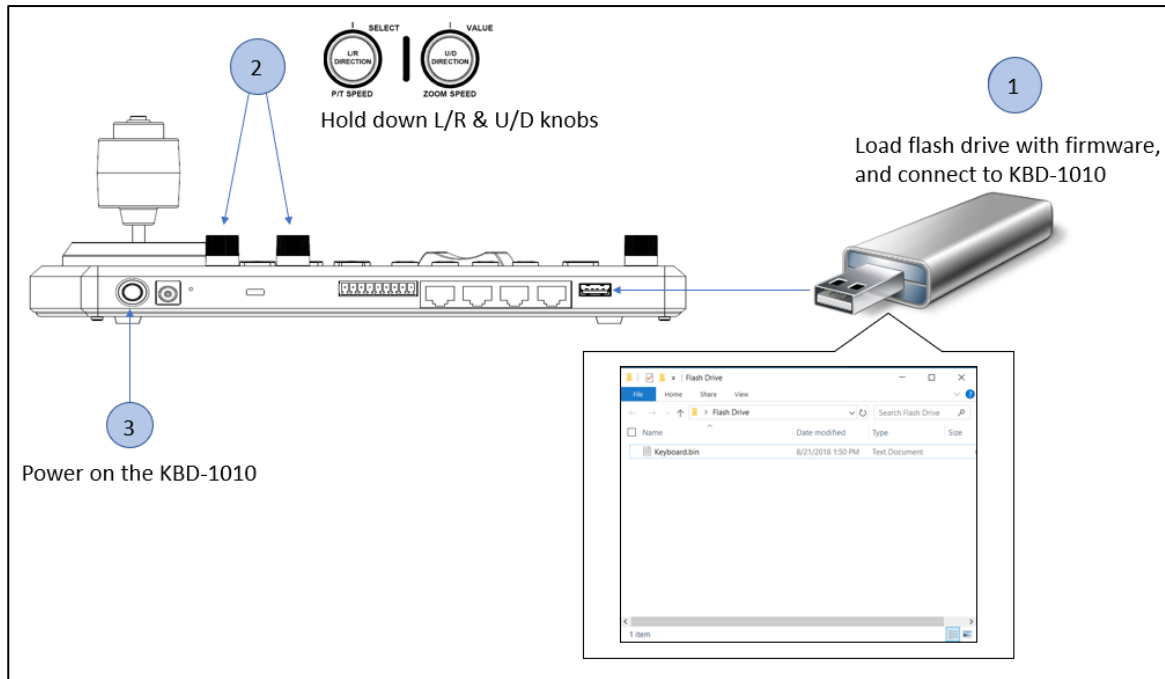

Download the latest firmware from Bolin website or your dealer or consulting Bolin technical support.

Keyboard MCU firmware upgrade.

This process begins with the keyboard powered off.

1. Load a flash drive with the “KEYBOARD.bin” firmware file in the root directory (not inside of a folder), and place the flash drive into the USB port on the back panel of the KBD-1010
2. Hold down the L/R Direction knob and the U/D Direction Knob
3. While holding the knobs down, power on the keyboard by clicking the power button into the “On” position. The keyboard will display a confirmation that the upgrade is taking place
4. When the upgrade is finished, power cycle the keyboard.

Keyboard IP firmware upgrade.

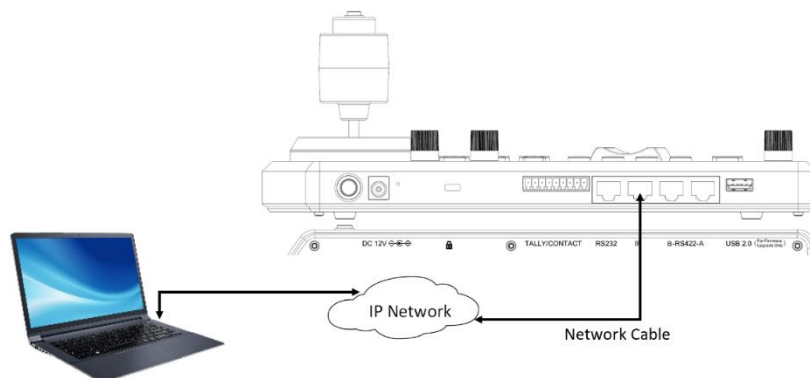

Connect PC to the keyboard via LAN

1. Connect PC to the keyboard via LAN within the same subnet network.
2. Find IP address of the keyboard in the menu on keyboard, Setup>Keyboard Setting>Model Info.
3. If the IP address showing **VA.x.x**, use the **.img** file to upgrade the keyboard.
4. If the IP address showing **V2.x.x**, use the **.csf** file to upgrade the keyboard.
5. Login IP web interface via IE (Internet Explorer) browser using the IP address you found, default User Name: admin, Password: Keep the field empty.
6. Use the tab Upgrade and follow the prompt to finish the fw upgrade
7. How to make the firmware upgrade, please refer to User Manual Part Two.
8. Check the upgraded firmware version number in the menu Keyboard Setting>Model Info.

LCD Screen Setting Tree

SETUP Button	CAMERA SETTING	CAMXXX	001-255			
		TITLE	User entry using keypad			
		VISCA	Baud Rate	2400, 9600, 19200, 38400		
			Port	RS422 / RS232		
			PELCO-D	Baud Rate	2400, 9600, 19200, 38400	
		PELCO-P	Baud Rate	2400, 9600, 19200, 38400		
		ONVIF	IP Address	User entry using keypad		
			User Name	User entry using keypad		
			Password	User entry using keypad		
			Port	User entry using keypad		
		VISCAIP	IP Address	User entry using keypad		
			Payload	OFF / ON		
			Port	52381 / 1259 / User		
		EXIT				
		SETTING	IP CONFIGURATION	TYPE	STATIC, DHCP	
	IP Address			User entry using keypad		
	Subnet Mask			User entry using keypad		
	Gateway			User entry using keypad		
	Exit			User entry using keypad		
	Button Light		Level	0, 1, 2		
	ASSIGNED KEY		F1, F2, F3, F4, F5, F6	Wiper On, Wiper Off, Home Position, P/T Reset, Power Standby, Mute, Picture Freeze, Image Stabilizer, HL Compensation, Trace Memory Set, Trace Memory Call, Trace Memory Cancel, Camera1~Camera7, None		
			Exit			
	Factory Default		Yes?, No?			
	GPI I/O		Setting	Input, Output		
			Tally Mode	Normal, On Air		
			Command Sel	Standard, Expand		
			Camera Link	On, Off		
	Exit					
	PASSWORD SETTING		Old Password	User entry using keypad		
			New Password	User entry using keypad		
			Confirm	User entry using keypad		
			Save			
Exit						
Joystick Zoom	ON, OFF					
MODEL INFO	Exit					
VISCA IP SETTING	Payload Header		OFF / ON			
	Port		52381 / 1259 / User			
CONTROL MODE	PTZ Controller					
	Video Router Switch					
Exit						
EXIT						
SEARCH Button	VISCA-IP	Start Search	Yes	(Search Results)		
		No&Exit				
	ONVIF-IP	Start Search	Yes	(Search Results)		
		No&Exit				
INQUIRY Button	VISCA-IP	CAM, Call, Exit				
	ONVIF-IP	CAM, Call, Exit				

Dimensions

Unit: mm

KBD-1010

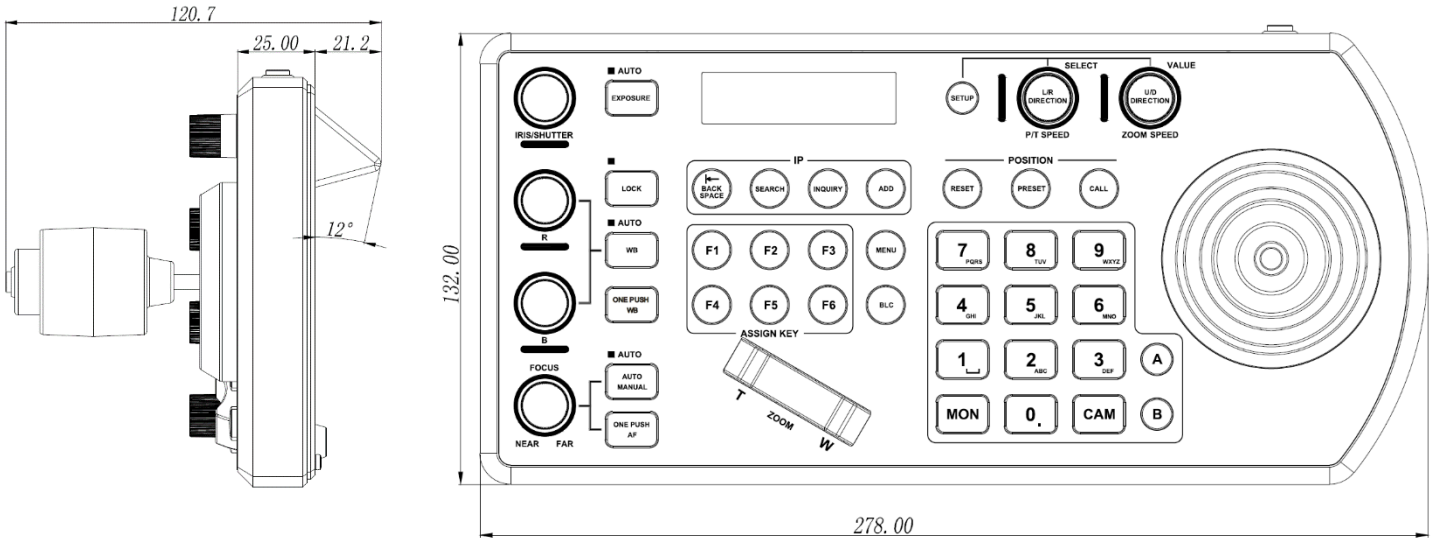

Junction Box

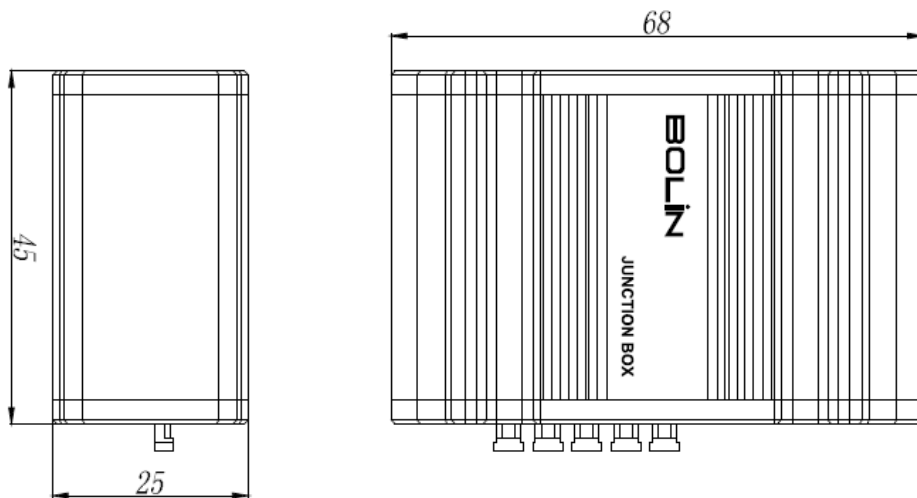



www.bolintechnology.com

2082 TECHNOLOGY LLC
dba
BOLIN TECHNOLOGY