

INTERCOM CONSOLE MODULE
ASSY 26/20 REV C COPYRIGHT 1998
BROADCAST TOOLS, INC.
C18 R16 K16 C10 R9 R10 R17
C17 R24 R23 R22
C16 D5 D4
9 0 11
EA 34

BROADCAST[®]
t o o l s **INC**
PROBLEM SOLVED

Installation and Operation Manual

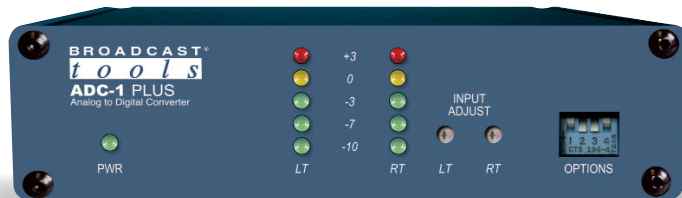

ADC-1 Plus
Analog to Digital Converter

Manual update: 06/16/2015

If you need a firmware upgrade, contact Broadcast Tools[®]

No part of this document may be reproduced or distributed without permission.
ALL SPECIFICATIONS AND FEATURES FOR THIS PRODUCT ARE SUBJECT TO
CHANGE WITHOUT NOTICE

NOTE: We recommend the use of Chrome, Firefox or Safari as your browser.

Due to the dynamic nature of product design, the information contained in this document is subject to change without notice. Broadcast Tools, Inc., assumes no responsibility for errors and/or omissions contained in this document. Revisions of this information or new editions may be issued to incorporate such changes.

*Broadcast Tools[®] is a registered trademark of Broadcast Tools, Inc.
tiny TOOLS[™] is a trademark of Broadcast Tools, Inc.
All Sentinel[®] labeled products are registered trademarks of Broadcast Tools, Inc.
Copyright[®] 1989 - 2015 by Broadcast Tools, Inc. All rights reserved.
No part of this document may be reproduced or distributed without permission.*

Visit www.broadcasttools.com for important product update information.

INTRODUCTION

Thank you for your purchase of the Broadcast Tools® **Analog to Digital Converter 1 Plus**, which we will refer to throughout the manual as the ADC-1 Plus. We're confident this product will give you many years of dependable service. This manual is intended to give you all the information needed to install and operate the product.

SAFETY INFORMATION

Broadcast Tools, Inc., is unable to support NON-Broadcast Tools software/hardware or NON-Broadcast Tools computer hardware/software problems. If you experience these problems, please research your hardware/software instruction manuals or contact the manufacturers technical support department.

Only qualified personnel should install Broadcast Tools® products. Incorrect or inappropriate use and/or installation could result in a hazardous condition.

WHO TO CONTACT FOR HELP

If you have any questions regarding your product or you need assistance, please contact your distributor from whom you purchased this equipment.

If you would like more information about Broadcast Tools® products, you may reach us at:

Broadcast Tools, Inc.

131 State Street
Sedro-Woolley, WA 98284-1503 USA
Voice: 360.854.9559
Fax: 866.783.1742

Internet Home Page: www.broadcasttools.com
E-mail: support@broadcasttools.com

**THANK YOU FOR CHOOSING
BROADCAST TOOLS® BRAND PRODUCTS!**

Broadcast Tools is a Veteran Owned Business



Designed, Assembled and Supported in WA State, USA



CAUTION!

Broadcast Tools® Products, as with any electronic device, can fail without warning. Do not use this product in applications where a life threatening condition could result due to failure.



NOTE:

This manual should be read thoroughly before installation and operation.

WEBSITE:

Visit our web site for product updates and additional information.

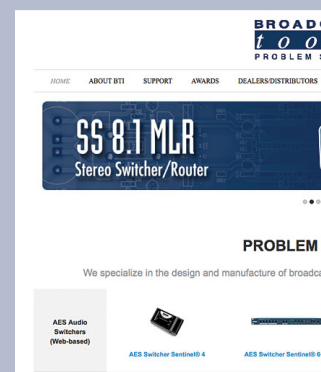

PRODUCT DESCRIPTION

The ADC-1 Plus provides professional quality analog to 24-bit digital audio conversion. The ADC-1 Plus is a perfect companion for converting the analog output of equipment (EAS encoders, etc) to stereo AES. The A/D converter may be configured for sample rates of 44.1 or 48kHz or use an external word clock from 32 to 96kHz. Features: balanced stereo analog inputs and AES output via XLR connectors. The front panel is equipped with left and right analog input trimmers, options dip-switch, LED level meters, and power LED indicator. The ADC-1 Plus is powered by a surge protected bi-polar 15 VDC power supply affording superior headroom and high definition audio. The ADC-1 Plus may be set on a desktop, mounted on a wall or up to three units may be mounted on the optional RA-1, Rack-Able mounting shelf.

INSTALLATION

Please examine your ADC-1 Plus carefully for any damage that may have been sustained during shipping. If any is noted, please notify the shipper immediately and retain the packaging for inspection by the shipper. The package contains the ADC-1 Plus and a +/-15 VDC wall power supply with domestic AC power connector. Manuals may be downloaded from our web site.

Installation of the ADC-1 Plus in high RF environments should be performed with care. Shielded cable is suggested for all audio connections. All shields should be tied to the "G" Ground terminals. The station ground should be connected to the chassis ground screw labeled "CHS GND." It is recommended that all cables connected to the ADC-1 Plus be looped through ferrite cores to suppress RF. Surge protection with RF filtering such as the Tripp-Lite "ISOBAR 4 or 6" is also suggested for the wall transformer.

L/R ANALOG INPUTS Hi Z, active balanced. Connect your source equipment to the left/right input XLR connections. For monaural sources, tie the left and right inputs together, be sure to observe correct phasing. NOTE: If the source feeding the ADC-1 Plus is unbalanced, install a jumper between LT- or RT- pins and GND.

AES OUTPUT Connect this XLR connector to the AES input on your equipment.

WORD CLOCK INPUT Balanced word clock input. Accepts all standard digital audio sample rates from 32 to 96kHz. Must be configured to activate this input.

FRONT PANEL OPTIONS SWITCH

SW1-1 OFF: 44.1 kHz sample rate (factory default).
ON: 48 kHz sample rate.

SW1-2 OFF: External Clock
ON: Internal Clock (factory default).

SW1-3 OFF: External clock range: 30 to 59 kHz.
ON: External clock range: 44.1 to 96 kHz (factory default).

SW1-4 Unused

WEBSITE:

Visit our web site for product updates and additional information.

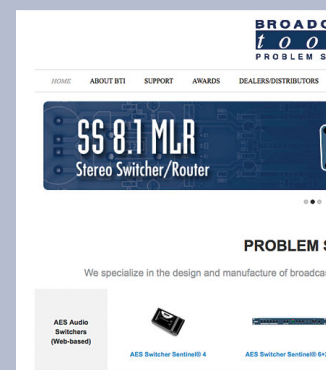

DESCRIPTION

OPERATION

- Power** Insert the power plug into the power jack on the ADC-1 Plus and the wall transformer into the proper AC outlet. Verify that the power LED is lit.
- Input Adjust LT/RT** Adjust these controls to the desired AES output level. Set to +4 dBu = -20dbFS at the factory.
- Left VU calibrate trimmer – R5.** **Right VU calibrate trimmer – R6.**

WEBSITE:

Visit our web site for product updates and additional information.

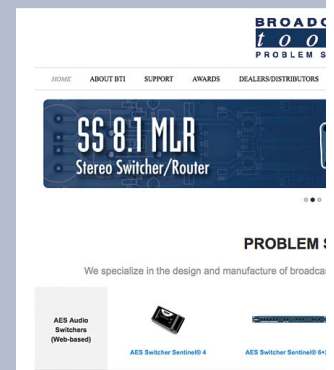

Specifications

Analog Input Level	0dBu to +24dBu. +4dBu analog input provides -20dBfs AES output when adjusted with the front panel trimmers.
Analog Input Impedance	10K Ω balanced.
Frequency Response	10 to 20kHz +/- 0.5dB.
Distortion	<.001%THD / IMD
Noise	<108dB Ref
AES Output Impedance	110 Ω , balanced.
Word clock input impedance	75 Ω , balanced
Word clock input level	5 volts
Word clock PLL input range	32 to 96kHz
Connectors	Analog inputs, AES output connections: XLR connectors, Word Clock; BNC
Power Requirements	Universal switching power supply with domestic AC connector supplied. +/-15 VDC 400mA output with 3-pin AMP-style latching power connector.
Size:	5.66" x 7.00" x 1.58", Painted aluminum chassis w/ 4 - 4-40 mounting holes.
Weight:	2.0 lb.
Options:	RA-1 rack shelf, holds three units (1-RU) / Filler panels supplied. International connectors optional.

WEBSITE:

Visit our web site for product updates and additional information.

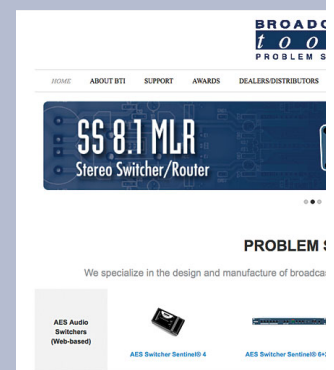

LIMITED WARRANTY

The term "Buyer" as used in this document refers to and includes both (but only) (a) any person or entity who acquires such an item for the purpose of resale to others (i.e., a dealer or distributor of an item), and (b) the first person or entity who acquires such an item for such person's or entity's own use.

Broadcast Tools warrants to each Buyer of any item manufactured by Broadcast Tools that the item will be free from defects in materials and workmanship at the time it is shipped by Broadcast Tools if the item is properly installed, used and maintained.

EXCLUSIVE REMEDIES

If Broadcast Tools is notified, in writing, of a failure of any item manufactured by Broadcast Tools to conform to the foregoing Limited Warranty within one (1) year following the date of the Buyer's acquisition of the item, and if the item is returned to Broadcast Tools in accordance with Broadcast Tools' instructions for confirmation by inspection of the defect (which at Broadcast Tools' election may include, without limitation, a requirement that the Buyer first obtain a Return Authorization number from Broadcast Tools, that the Buyer furnish proof of purchase in the form of an invoice and/or receipt, and that the Buyer prepay all freight charges associated with any return of the item to Broadcast Tools using such freight service as Broadcast Tools reasonably may specify), Broadcast Tools will repair or replace the defective item, or will refund the purchase price paid by the Buyer for the item. Broadcast Tools shall have the exclusive right to choose between these alternative remedies.

NO OTHER WARRANTIES OR REMEDIES

TO THE MAXIMUM EXTENT PERMITTED BY APPLICABLE LAW, BROADCAST TOOLS AND ITS SUPPLIERS DISCLAIM ALL OTHER WARRANTIES, EITHER EXPRESS OR IMPLIED, INCLUDING BUT NOT LIMITED TO IMPLIED WARRANTIES OF MERCHANTABILITY OR FITNESS FOR A PARTICULAR PURPOSE; AND THE FOREGOING ALTERNATIVE REMEDIES SHALL BE EXCLUSIVE OF ALL OTHER REMEDIES. THIS LIMITED WARRANTY GIVES YOU SPECIFIC LEGAL RIGHTS. YOU MAY HAVE OTHER RIGHTS, WHICH VARY FROM STATE/JURISDICTION TO STATE/JURISDICTION.

NO LIABILITY FOR CONSEQUENTIAL DAMAGES

TO THE MAXIMUM EXTENT PERMITTED BY APPLICABLE LAW, NEITHER BROADCAST TOOLS NOR ANY OF ITS SUPPLIERS SHALL HAVE ANY LIABILITY FOR ANY SPECIAL, INCIDENTAL, INDIRECT, CONSEQUENTIAL OR PUNITIVE DAMAGES WHATSOEVER (INCLUDING, WITHOUT LIMITATION, ANY DAMAGES FOR LOST PROFITS, BUSINESS INTERRUPTION, LOSS OF DATA OR INFORMATION, COST OF CAPITAL, CLAIMS OF CUSTOMERS, OR ANY OTHER PECUNIARY LOSS) ARISING OUT OF THE USE OF OR THE INABILITY TO USE ANY ITEM SUPPLIED BY BROADCAST TOOLS, EVEN IF BROADCAST TOOLS HAS BEEN ADVISED OF THE POSSIBILITY OF SUCH DAMAGES HAVE ANY LIABILITY FOR ANY SPECIAL, INCIDENTAL, CONSEQUENTIAL, EXEMPLARY OR PUNITIVE DAMAGES. THIS LIMITATION OF LIABILITY APPLIES WHETHER A CLAIM IS ONE ALLEGING BREACH OF A CONTRACT OR WARRANTY, NEGLIGENCE OR OTHER TORT, FOR THE VIOLATION OF ANY STATUTORY DUTY, THE FAILURE OF ANY LIMITED OR EXCLUSIVE REMEDY TO ACHIEVE ITS ESSENTIAL PURPOSE, OR ANY OTHER CLAIM OF ANY NATURE. BECAUSE SOME STATES AND JURISDICTIONS DO NOT ALLOW THE EXCLUSION OR LIMITATION OF LIABILITY FOR INCIDENTAL OR CONSEQUENTIAL DAMAGES, THIS LIMITATION MAY NOT APPLY TO YOU.

Broadcast Tools, Inc.

131 State Street
Sedro-Woolley, WA 98284 • USA

360.854.9559 **voice** • 866.783.1742 **fax**
support@broadcasttools.com **e-mail**
www.broadcasttools.com **website**

Functional Diagram

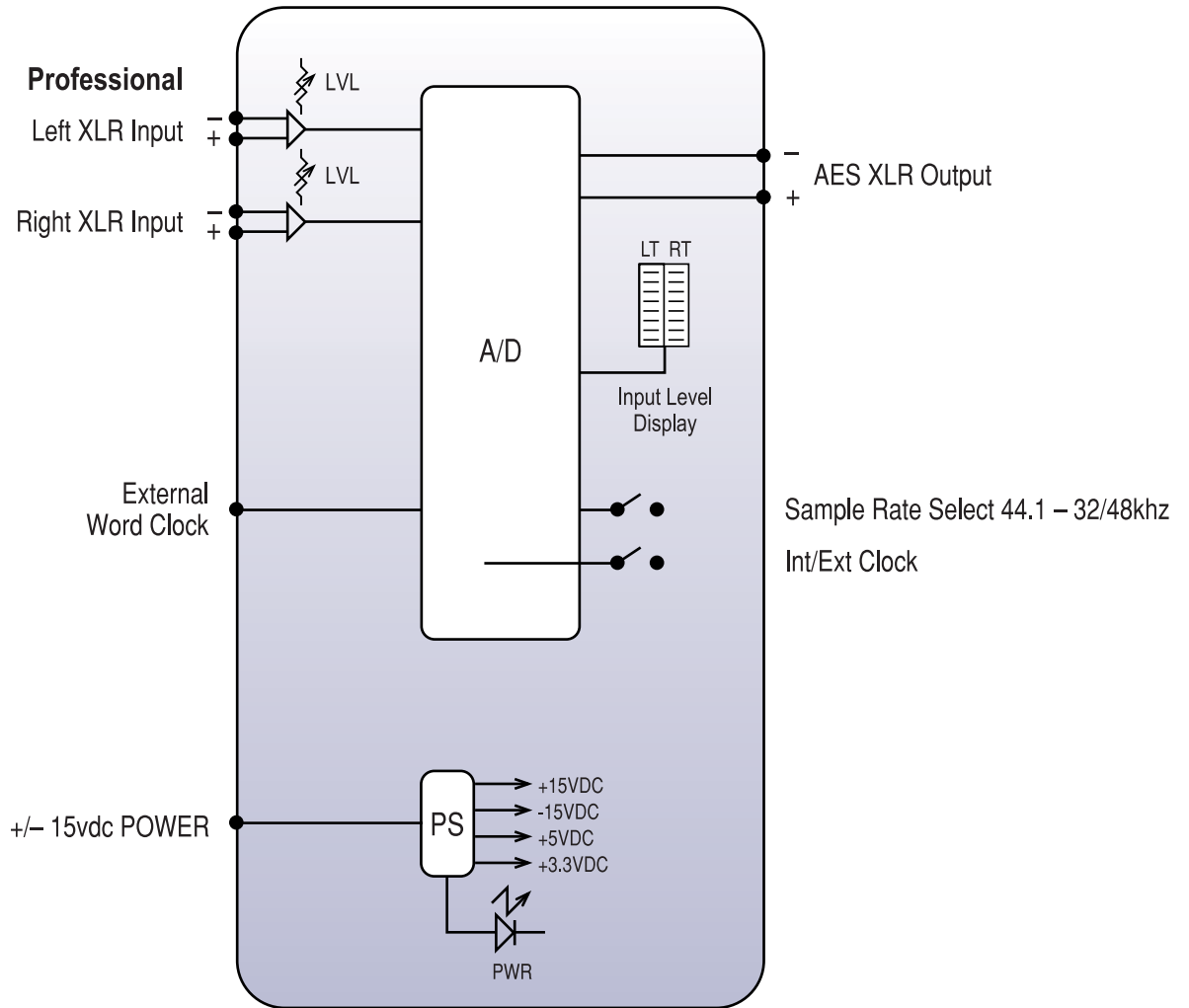



Broadcast Tools® ADC-1 Plus

Jumper and Connection Layout

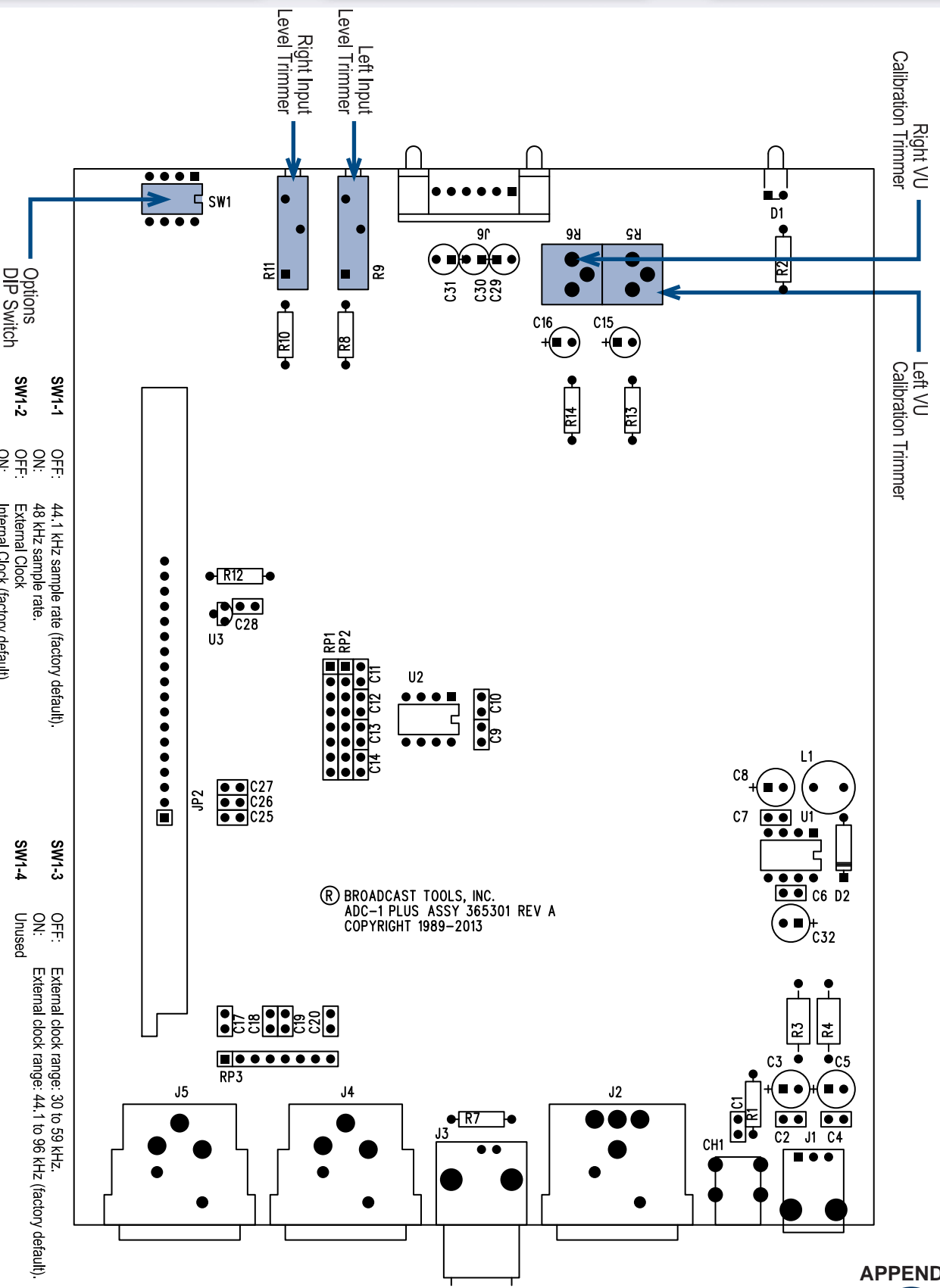

© BROADCAST TOOLS, INC.
 ADC-1 PLUS ASSY 365301 REV A
 COPYRIGHT 1989-2013

SW1-1	OFF: 44.1 kHz sample rate (factory default). ON: 48 kHz sample rate.	SW1-3	OFF: External clock range: 30 to 59 kHz. ON: External clock range: 44.1 to 96 kHz (factory default).
SW1-2	OFF: External Clock ON: Internal Clock (factory default).	SW1-4	Unused

131 State Street, Sedro-Woolley, WA 98284 • 360.854.9559 • Fax 866.783.1742
 Visit us online at www.broadcasttools.com
 Copyright © 1989-2013 by Broadcast Tools, Inc. All Rights Reserved.
 Modification Date: 10/23/13

Fractional Schematic

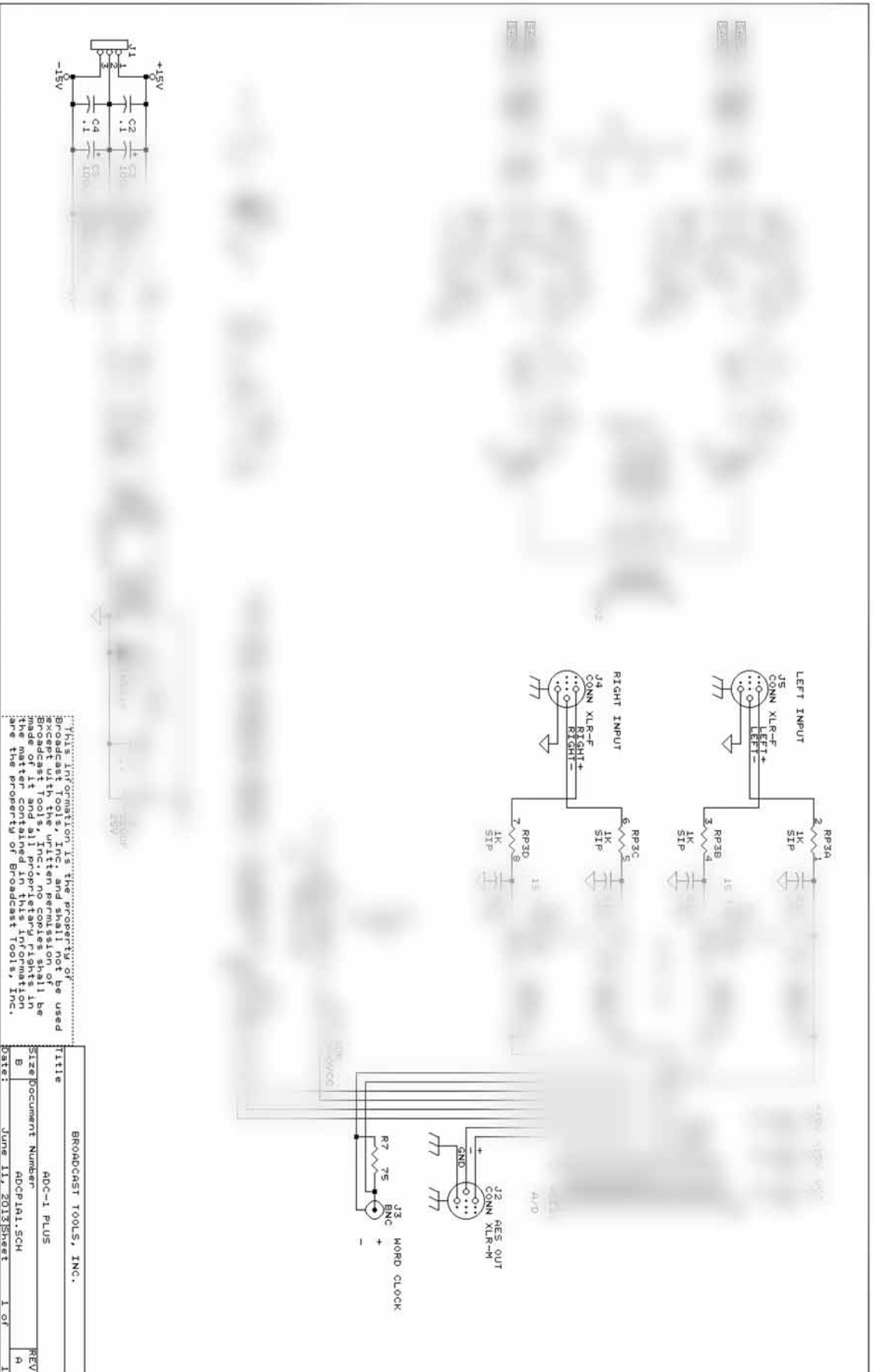

This information is the property of Broadcast Tools, Inc. and shall not be used for any other purpose. No copies shall be made of it and all proprietary rights in the matter contained in this information are the property of Broadcast Tools, Inc.

BROADCAST TOOLS, INC.	
Title	ADC-1 PLUS
Size	Document Number
B	ADCP1A1.SCH
Date:	June 11, 2013
Sheet	1 of 1
REV	A