

# BROADCAST<sup>®</sup> tools INC

## *Installation and Operation Manual*



### Site Sentinel™ 4 *Web Based Four Channel Site Remote Control System*

V2\_Manual updated: 8/29/2018

For firmware versions equal to or greater than SSP\_V1.06 / SS4X0x\_v2.20 / SSW\_V1.42.  
If you need a firmware upgrade, contact Broadcast Tools®

No part of this document may be reproduced or distributed without permission.  
ALL SPECIFICATIONS AND FEATURES FOR THIS PRODUCT ARE SUBJECT TO  
CHANGE WITHOUT NOTICE

**NOTE: We recommend the use of Chrome, Firefox or Safari as your browser.**

Due to the dynamic nature of product design, the information contained in this document is subject to change without notice. Broadcast Tools, Inc., assumes no responsibility for errors and/or omissions contained in this document. Revisions of this information or new editions may be issued to incorporate such changes.

*Broadcast Tools® is a registered trademark of Broadcast Tools, Inc.  
All Sentinel™ labeled products are a trademark of Broadcast Tools, Inc.  
Copyright © 1989 - 2018 by Broadcast Tools, Inc. All rights reserved.  
No part of this document may be reproduced or distributed without permission.*

Visit [www.broadcasttools.com](http://www.broadcasttools.com) for important product update information.

## Table of Contents

Section Title	Page #
Introduction .....	3
Safety Information .....	3
Who to Contact for Help .....	4
Product Overview .....	5
Inspection .....	6
Installation .....	6
Surge Protection .....	6
UPS Standby Power System .....	6
Front panel indicators and controls .....	6
Rear panel connections .....	7
Connecting your Site Sentinel 4 to external equipment .....	8
Metering Inputs .....	8
Status/Logic Inputs .....	9
Control Relays .....	9
Power Failure input .....	9
Silence Sensor input .....	10
Temperature Probe input .....	10
Power Control Relay .....	10
“NET” RJ45 network connector .....	10
7.5 VDC POWER connector .....	10
Web Setup/Operation .....	11
Ethernet “Quick Start” Guide .....	12
Opening the LOGIN Web Page .....	13
“Login” Web Page .....	14
“Monitor/Control” Web Page .....	15
“User Setup” Web Page .....	16
“Temperature” Setup page .....	17
“Metering” Setup page .....	19
“Status/Logic” Setup page .....	21
“Relays 1–4” Setup page .....	23
“Silence Sensor” Setup page .....	26
“Power Failure” Setup page .....	27
Restoring Network Factory Defaults .....	28
“Scheduler Setup” Setup page .....	29
“Email/Network Setup” Web Page .....	32
“Show Log” Web Page .....	36
“About” Web Page .....	37
Specifications .....	38
Warranty .....	39
Declaration of Conformity .....	40
Fractional Schematic .....	Appendix
Circuit board assembly drawing with jumper notations .....	Appendix
Front and rear chassis drawings .....	Appendix
Functional drawing .....	Appendix
Typical I/O configuration drawing .....	Appendix

### WEBSITE:

*Visit our web site for product updates and additional information.*

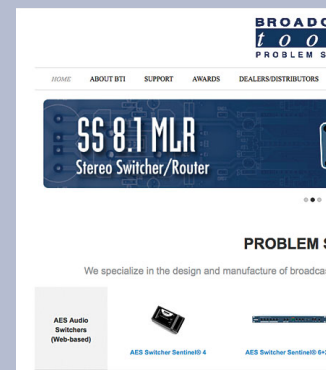

### CONTENTS

## INTRODUCTION

Thank you for your purchase of Broadcast Tools® Site Sentinel™ 4 Web based Four Channel Site Remote Control System (referred to as the Site Sentinel™ 4 throughout this manual). We're confident that this product will give you many years of dependable service. This manual is intended to give you all the information needed to install and operate the Broadcast Tools® Site Sentinel™ 4.

Broadcast Tools®, Inc., is unable to support NON-Broadcast Tools® hardware/software or NON-Broadcast Tools® computer hardware/software problems. If you experience these problems, please research your hardware/software instruction manuals or contact the manufacturer's technical support department.

## SAFETY INFORMATION

**CAUTION!** Only qualified technical personnel should install the Site Sentinel™ 4. Any attempt to install this device by a person who is not technically qualified could result in a hazardous condition to the installer or other personnel, and/or damage to the Site Sentinel™ 4 or other equipment. Broadcast transmitters can operate at voltages that are potentially lethal. Please ensure that proper safety precautions have been made before installing this device. If you are unfamiliar with this type of equipment, please contact a properly qualified engineer to handle the installation and setup of the Site Sentinel™ 4.

Broadcast Tools® Products, as with any electronic device, can fail without warning. Do not use this product in applications where a life threatening condition could result due to failure. Serious injury or death can occur if a command channel is activated while you are performing maintenance on your equipment. If you are performing maintenance on your equipment, you should press the "LOCAL" button on the front panel of your Site Sentinel™ 4 forcing the unit in to local mode. The "LOCAL" LED will illuminate. Local mode prevents the unit from performing relay commands.

For additional safety, it is strongly recommended that, in addition to setting the Site Sentinel™ 4 in to "LOCAL" mode, the remote/local switch on any transmitter or high voltage equipment should also be set to local mode.

While the Site Sentinel™ 4 relays are physically capable of handling 250 VAC, this practice is extremely dangerous and should never be attempted. The removable euroblock screw terminals are not designed to shield humans from potentially dangerous voltages. Contact with high voltages can cause serious injury or death. The maximum recommended voltage for the Site Sentinel™ 4 is 30V. Switching of high voltages should only be done external from the Site Sentinel™ 4 and in a manner that isolates the voltages from accidental contact with humans.



**CAUTION!**

**Broadcast Tools®** Products, as with any electronic device, can fail without warning. Do not use this product in applications where a life threatening condition could result due to failure.



**NOTE:**

This manual should be read thoroughly before installation and operation.

Find a contract Broadcast Engineer in your area? Check out this link: [http://www.sbe.org/CCE\\_List.php](http://www.sbe.org/CCE_List.php)

## WEBSITE:

*Visit our web site for product updates and additional information.*

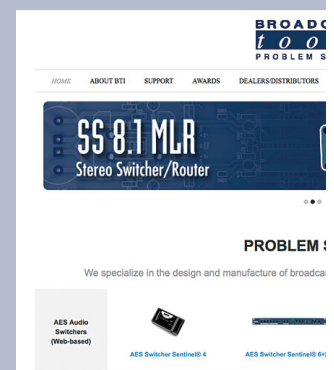

## WHO TO CONTACT FOR HELP

If you have any questions regarding your product or you need assistance, please contact your distributor from whom you purchased this equipment.

If you would like more information about Broadcast Tools® products, you may reach us at:

### **Broadcast Tools, Inc.**

131 State Street

Sedro-Woolley, WA 98284-1540 USA

Voice: 360.854.9559

Fax: 866.783.1742

Internet Home Page: [www.broadcasttools.com](http://www.broadcasttools.com)

E-mail: [support@broadcasttools.com](mailto:support@broadcasttools.com)

***THANK YOU FOR CHOOSING  
BROADCAST TOOLS® BRAND PRODUCTS!***

Broadcast Tools is a Veteran Owned Business



Designed, Assembled and Supported in WA State, USA

## **WEBSITE:**

*Visit our web site for product updates and additional information.*

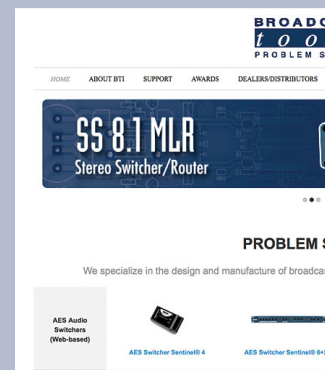

## Product Overview

The Site Sentinel™ 4 provides a cost-effective, one third-rack solution for web based site remote control. The Site Sentinel™ 4 was designed from a user's point of view, so all of the basic functionality you need is included to control your site equipment, while including the accessories other manufacturers consider optional. Each analog (metering), status/logic, stereo silence sensor, temperature sensor (probe optional), power failure inputs, along with all relays can be controlled and/or monitored over any IP network including private networks, IP-based industrial control networks, and the Internet. Users can operate the product using a web browser or web-enabled mobile device, while email notification may be configured to alert up to four recipients when alarms are detected. The user may also enable a sound effect to play on the monitoring PC when an alarm is generated. Logging of system status, along with the site ID may be emailed in time spans from once an hour to once a day. SNMP and SMTP username and passwords are also supported.

The Site Sentinel™ 4 is equipped with four buffered high-resolution 10 volt metering (analog) channels, while each of the four optically isolated status/logic channels may be configured for 5 to 24 volts DC wet or dry (contact closures) status/logic monitoring. The four control channels are equipped with independent SPST one-amp relays and may be latched on, off or pulsed with user configured timing along with user programmable action sequences. The temperature monitoring is within the range of -67°F to +257°F (-55°C TO +125°C).

The Site Sentinel™ 4 is also equipped with a power controller port. By pairing this feature with an optional external AC power control unit (such as the Mid-Atlantic RLM-15-1C, RLM-20-1C or RLM30-L530-1) remote rebooting of equipment is possible.

## Additional Features

- Plug-in euroblock screw terminals for metering (analog), status/logic, control relays and stereo silence sensor.
- Jack for external power failure (optional) power supply,\*
- 1/8" T/R/S mini-jack for the optional Fahrenheit or Celsius temperature sensor.\*
- Stereo Silence Sensor monitoring.\*
- Front panel LED indicators for most operational activities.
- Front panel local/operate switch with LED indicator.
- Rear panel RJ-45, 10/100base-T LAN/Ethernet interface.
- Fully RFI proofed.
- Surge protected power supply.
- Third rack, 1-RU high chassis.
- 120 VAC to 7.5 VDC @ 1 amp (optional 240V CE) power supply included.

\* Denotes independent of the four metering (analog) and status/logic channels.

## WEBSITE:

Visit our web site for product updates and additional information.

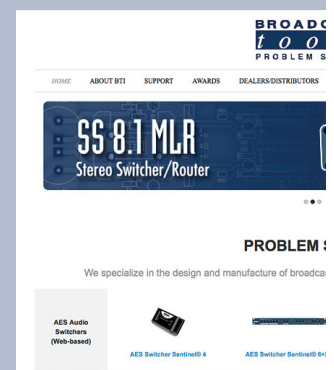

## OVERVIEW

## Inspection

Please examine your Site Sentinel™ 4 carefully for any damage that may have been sustained during shipping. If any is noted, please notify the shipper immediately and retain the packaging for inspection by the shipper. The package should contain the Site Sentinel™ 4, this manual and/or CD, 7 foot BLUE straight-through CAT 5 cable, 7 foot GRAY crossover CAT 5 cable and the 7.5 VDC @ 1 amp wall transformer.

## Installation

### Surge Protection

The Site Sentinel™ 4 has built-in resistance to voltage changes, we recommend that you use a power surge protector or line conditioner on the incoming AC line. Lightning strikes and other high surges in voltage levels will damage your Site Sentinel™ 4 and connected equipment if it is not properly protected. For lightning protection devices, check out [www.polyphaser.com](http://www.polyphaser.com) and [www.itwlinx.com](http://www.itwlinx.com).

### UPS Standby Power System

We recommend that you connect your Site Sentinel™ 4 to a UPS system. While all operating and user parameters are stored in non-volatile EEPROM, brownout conditions and lightning induced spikes can disable or damage equipment. A UPS helps minimize the risk to the Site Sentinel™ 4 and has the added benefit that it will then be able to notify you of the power outage by email.

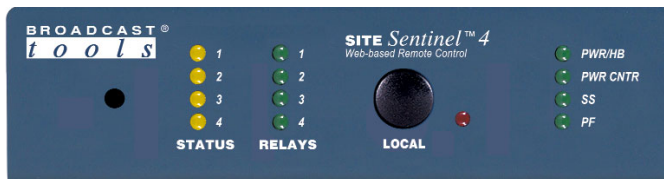

### Front panel indicators and controls

Name	Type	Description
Default	Push Button	Recessed push button used to reload factory defaults.
Status 1 - 4	LED	Illuminates when the corresponding status/logic inputs are activated.
Relays 1 - 4	LED	Illuminates when the corresponding relays are activated.
LOCAL	Push Button	Toggles between operate and local mode.
LOCAL	LED	Illuminated when the unit is in local mode.



## CAUTION!

Installation of the Site Sentinel™ 4 in high RF environments should be performed with care. Shielded cable is suggested for all monitoring and control connections with all shields tied to the station/site ground terminal. The station/site ground should be connected to the rear panel (CGnd) chassis ground terminal or screw stud using an 18 or 20-gauge wire.

### WEBSITE:

Visit our web site for product updates and additional information.

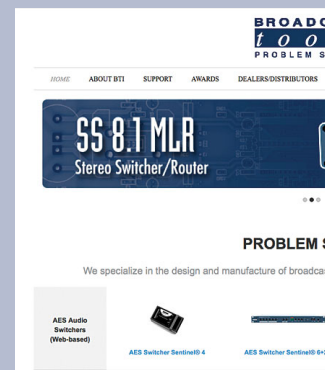

## INSTALLATION

## Front panel indicators and controls

Name	Type	Description
PWR/HB	LED	Illuminated when valid power is applied to the power jack.
PWR CNTR	LED	Illuminated when the relay is activated.
SS	LED	Illuminated when adequate audio is applied to the SS Input(s), OFF when the level is too low and flashing if in an SS alarm condition, if enabled.
PF	LED	Illuminated when power is applied, OFF when inadequate DC voltage is applied to the PF jack and flashing if a Power Failure has been detected, if enabled.

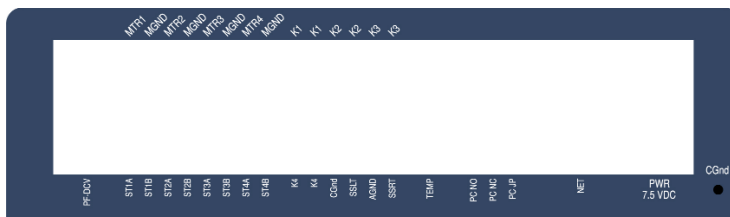

## Rear panel connections

Name	Type	Description
PF	2.1mm Jack	Power Failure power jack (optically-isolated). 5 -12 VDC power supply optional.
MTR 1 - 4	Connector	Metering (analog) inputs one thru four (Top).
MGND	Connector	Metering (analog) ground reference terminal (Top).
ST1A - 4A	Connector	Status/logic opto-isolators. When configured for DRY, (factory default) this terminal is ground. When configured for WET (floating), this terminal is the anode via a 2.2K ohm current limiting resistor (Bottom).
ST1B - 4B	Connector	Status/logic opto-isolators. This terminal is always the cathode (Bottom).
K1 - K3	Connector	Normally Open, dry relay contacts (Top).
K1 - K3	Connector	Normally Open, dry relay contact (Top).
K4	Connector	Normally Open, dry relay contact (Bottom).
K4	Connector	Normally Open, dry relay contact (Bottom).
CGnd	Connector	Chassis ground terminal. Tie to site/station ground.

Name	Type	Description
SSLT	Connector	Unbalanced Silence Sensor left audio input (Bottom).
GND	Connector	Silence Sensor audio ground (Bottom).
SSRT	Connector	Unbalanced Silence Sensor right audio input (Bottom). <b>NOTE: Left and right summed to monaural internally.</b>
TEMP	3.5mm Jack	Temperature probe input jack. (Temp probe optional) 1/8" (3.5mm) T/R/S mini-jack.
PCNO	Connector	Power controller normally open relay contact.
PCNC	Connector	Power controller normally closed relay contact.
PCJP	Connector	Power controller internal function jumper.
NET	Connector	RJ45 network connector.
PWR 7.5 VDC	2.1mm Jack	System power supply input. 7.5 volts DC @ 1 amp. <b>NOTE: Center positive.</b>
CGnd	# 4 Stud	Chassis ground 4-40 stud with nut. Tie to site/station ground.

**NOTE: See alternate "CGnd" chassis ground on terminal block.**

## Connecting your Site Sentinel™ 4 to external equipment

### Metering (analog) inputs

#### **CAUTION!**

Metering (analog) input samples may be elevated several hundred volts above ground on some external equipment. Permanent damage may occur to the Site Sentinel™ 4 and/or external equipment if a high voltage metering source is connected to the Site Sentinel™ 4! Failure to observe this warning may also cause injury to the installer or other personnel. **DO NOT CONNECT SAMPLE VOLTAGES IN EXCESS OF POSITIVE 10 Volts DC OR DAMAGE MAY OCCUR TO YOUR Site Sentinel™ 4.**

#### **CAUTION! Floating Grounds**

Except for status/logic (wet) inputs, none of the Site Sentinel™ 4's metering inputs will accept a floating ground. Damage to the Site Sentinel™ 4 or your equipment may result from connecting a floating ground output to the Site Sentinel™ 4. If you require metering equipment with inputs that have a floating ground, an isolation DC amplifier should be used.

Four buffered metering (analog) input channels are available with the Site Sentinel™ 4 via removable euroblock screw terminals. Connect the positive side of the source to the desired channel terminal labeled MTRx (where x is the channel number 1 through 4) and associated MGND (metering ground) terminals.

#### **WEBSITE:**

*Visit our web site for product updates and additional information.*

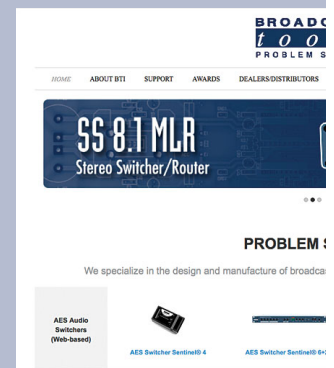



## Installation

Each buffered metering (analog) input can handle up to (positive only) 10 volts DC and must be ground referenced and connected to the associated MGND ground terminal. Inputs are self-calibrating and are based on an internal A/D converter with a precision, low-drift voltage reference, so the reading should not drift over time or with temperature. Metering setup is performed by connecting the sample voltage to the MTRx and MGND metering (analog) input, then calibrate for the desired value (reading).

## Status/Logic Inputs

Each optically isolated status/logic inputs can be configured to accept either a contact closure (DRY = default) or a (floating, WET) input. Attach your dry contacts to the desired status/logic channels StxA and STxB (where x is the status/logic input channel) terminals.

Each input is equipped with a four-position header (please refer to the jumper layout in the appendix). JPR1 supports status/logic input one, JPR2 status/logic input two, JPR3, status/logic input three and JPR4, status/logic input four. Each jumper (JPRx, where x is the status/logic input) and the header pins 1,2,3,4 (The pin closest to the J of the label JPRx, is pin 1) are used to configure for wet or dry operation. The factory default is DRY. (Switch, relay contact, open collector) with jumpers between 1 & 2 and 3 & 4. In the DRY configuration, the “A” terminal is ground while the “B” terminal is the cathode of the opto-isolator diode (pulled up to 5 volts through a 2.2K resistor).

To change the status/logic input to (floating) WET (user supplied voltage between 5 and 24 vdc), remove both jumpers and place ONE jumper over pins 2 & 3. Connect the positive voltage to terminal “A” (anode) and ground or minus voltage to terminal “B” (cathode). Please refer to the appendix for configuration examples.

**NOTE: Please observe proper polarity.**

## Control Relays

Each of the four control relays are supplied with a normally open dry contact. External equipment to be controlled should be connected to the terminals labeled Kx and Kx (where x is the control relay number) for relays one through four.

## Power Failure Input

Connect a user supplied 5 to 12 volts DC only power source (center positive) to the power failure input labeled PF. The barrel connector size is 2.1mm ID x 5.5mm OD. An inexpensive 5 to 12 volts DC wall transformer of any current of 25 ma or more will work.

**NOTE: The primary (120vac) of the wall transformer should be connected to the utility company side of your service. An UPS is suggested to power the Site Sentinel™ 4 during power outages.**



### NOTE:

Valid sample voltage **MUST** be applied to the metering inputs in order to perform calibration.



### NOTE:

If mechanical latching relays are required, we suggest the Broadcast Tools LR-5 (4PDT & SPST) mechanical latching relay.

## Installation

### **Silence Sensor Inputs**

Connect your unbalanced monaural or stereo audio source to the terminals labeled SSLT, SSRT and AGND. The level should be between -10 and +24 dbu. The input impedance is approximately 22K ohms. When the SSLT/RT input has audio applied and the silence sensor is activated, the front panel SS led is illuminated. If the SS led is out, the signal is too low and if it's flashing, it is in an alarm condition (if enabled).

### **TEMPerature Probe Input**

Insert the OPTIONAL temperature probe (25 foot cable) mini (3.5mm) plug in to the rear panel jack labeled "TEMP" -67°F to +257°F (-55°C TO +125°C).

**NOTE: Please limit the total length of cable to 50 feet. Please contact the factory for the proper extension cable. The temperature probe should only be installed or removed with the power supply disconnected from the Site Sentinel™ 4.**

### **Power Controller Relay**

The jumpers are set to provide the relay common (wiper) on the terminal labeled (PCJP). Please refer to the "Fractional Schematic" in the appendix for more jumper options.

### **NETWORK connector**

Connect one end of the supplied CAT5 (straight or x-over) cable to the desired ETH-ERNET (WAN/LAN) port.

### **PWR 7.5 VDC (Power) connector**

Connect the supplied 7.5 volt DC only 1 amp power supply cord in to the Site Sentinel™ 4's power jack (center positive) labeled "PWR 7.5 VDC", then plug the transformer in to a source of 120 vac 60Hz. Verify that the front panel green (PWR/HB) power led is illuminated.

## Web Setup and Operation

### **Ethernet "Quick Start" guide**

**CAUTION! If you are not familiar with Ethernet enabled equipment, it may be useful to contact your IT department, network administrator or network consultant for assistance. Assigning an IP address already in use by another device may cause problems with your network!**

Instructions for changing the IP address of the computer that will be used for the configuration of this product are given here. Note that these instructions are specifically for computers with the Windows XP operating system. For setup using other operating systems, refer to the appropriate OS user's manual.



## **CAUTION!**

NEVER DOWNLOAD FIRMWARE UPDATES OR CHANGES TO THE XPORT WEB-SERVER UNLESS INSTRUCTED TO DO SO BY BROADCAST TOOLS®. DOING SO DELETES ALL SOFTWARE AND VOIDS ALL WARRANTIES FROM BROADCAST TOOLS®, INC.

### **WEBSITE:**

*Visit our web site for product updates and additional information.*

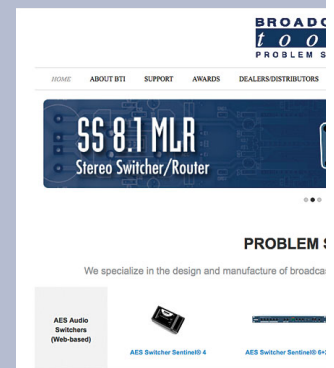

## **INSTALLATION**

## Web Setup and Operation

### Ethernet “Quick Start” guide

**Step 1:** Open the control panel by clicking on the start menu, click on settings, then click on Control Panel. (Note that the control panel shown is in “Classic View”. If control panel is in “Category View” select the “Classic View” option before proceeding.)

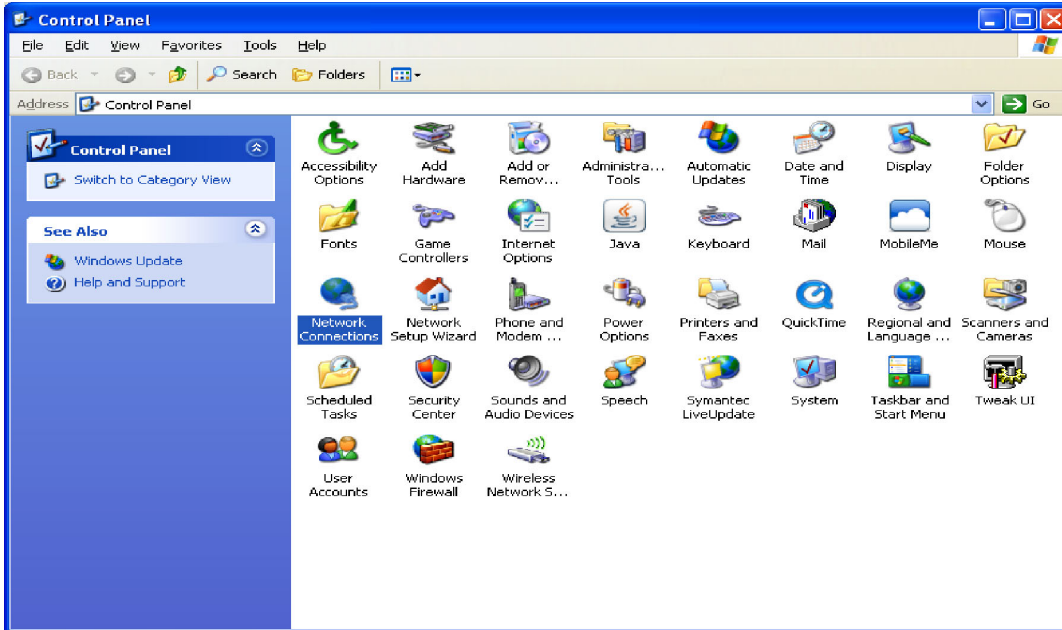

**Step 2:** Double click on the icon labeled Network Connections. The following menu will pop up.

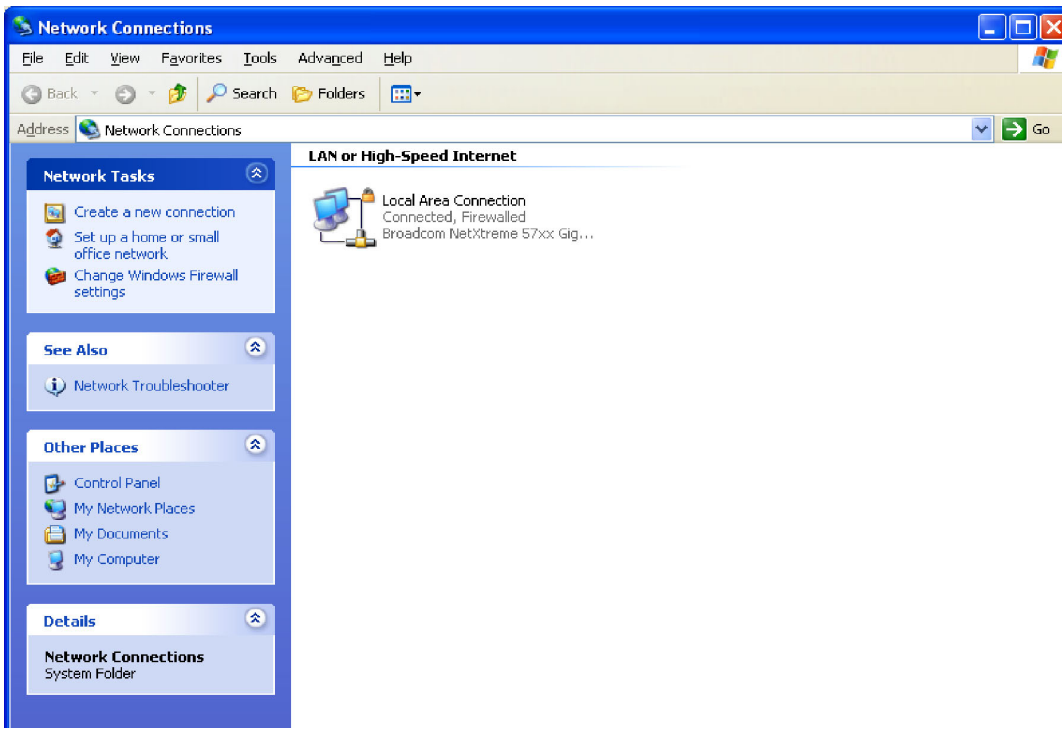

## Web Setup and Operation

### Ethernet “Quick Start” guide

**Step 3:** Right click on the icon labeled Local Area Connection. Another menu will appear. Select the option at the bottom of the menu labeled Properties. The Local Area Connection Properties window will appear.

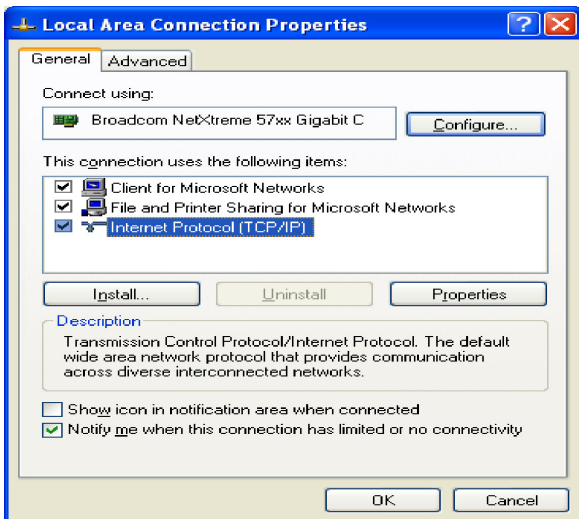

**Step 4:** On the Local Area Connection Properties page, double click on Internet Protocol (TCP/IP) to display properties.

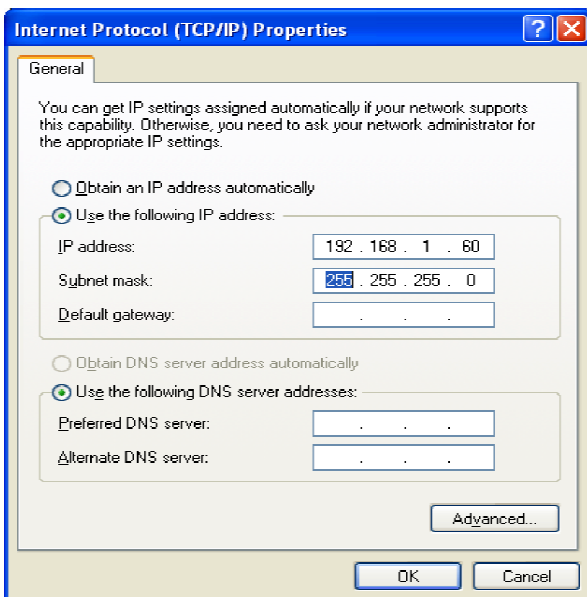

**Step 5:** Before making any changes to the network settings, write down the current settings (or screen capture the page and print) so that they can be restored once the unit is configured. Next, select the radio button labeled “Use the following IP address” and type in the IP address 192.168.1.60. Type in the subnet mask of 255.255.255.0. Leave the default gateway field blank. Click OK to apply the new settings.

### WEBSITE:

*Visit our web site for product updates and additional information.*

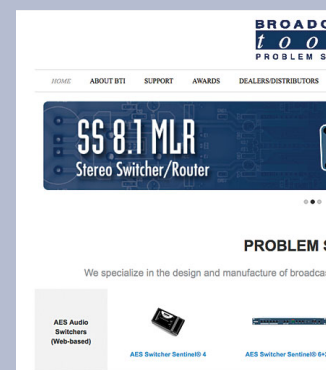

## Web Setup and Operation

### Opening the LOGIN Web Page

1. Connect the supplied GRAY colored XOVER cable between the PC's Ethernet port and the products "NET" network RJ45 jack.
2. Connect the supplied 7.5 VDC @ 1 amp power supply to the product's power jack labeled PWR 7.5 VDC. Verify that the green PWR/HB LED is ON and the left "LINK" LED above the "NET" Network RJ-45 connector is illuminated.

#### Ethernet (NETWORK) port LED indicator functions

Link LED Left Side	
Color	Meaning
Off	No Link
Amber	10 Mbps
Green	100 Mbps

Activity LED Right Side	
Color	Meaning
Off	No Activity
Amber	Half Duplex
Green	Full Duplex

3. Open the product's login page by typing the following URL into the browser: <http://192.168.1.55> A username and password is required to change any parameter and are case sensitive.

**Factory "login" defaults:**                      **username: admin (lower case)**  
**password: 1234**

4. Once you are logged in, follow this manual for setup and/or operational information.

## Web Setup and Operation

### “Login” Web Page

The Login screen displays the Username and Password entry points.

You may view the password by checking the “Show Password” box.

The screenshot shows the login interface for Site Sentinel™ 4. At the top left, there is a logo for 'BROADCAST tools' and the product name 'SITE Sentinel™ 4'. On the right side of the header, the word 'Login' is displayed. Below the header, there are two input fields for 'Time/Date', showing '14:19:20' and '11/11/2009'. A 'Site ID' field contains the text 'SITE\_ID'. Underneath, the text 'Enter Login Information:' is followed by a 'Username' field and a 'Password' field. To the right of the password field is a checkbox labeled 'show password'. At the bottom of the form is a 'SUBMIT' button.

After you have successfully logged in, the Monitor/Control page will be displayed. Depending on your access level, you may or may not be able to control or modify the product’s configuration.

### WEBSITE:

*Visit our web site for product updates and additional information.*

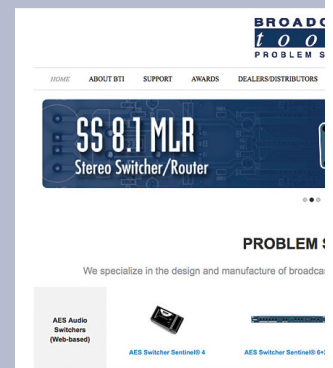

## Web Setup and Operation

### “Monitor/Control” Web Page

**BROADCAST tools** SITE Sentinel™ 4 Monitor/Control

**NAVIGATION**  
 About  
 Monitor/Control  
 User Setup  
 I/O Setup  
 Email/Network Setup  
 Show Alarms  
 Help  
 Logout

**Date:** 11/11/2009      **Site ID:** SITE\_ID  
**Time:** 14:20:10      **Label/Temp:** Temp Label:69 °F  
**Queued Logs:** Disabled

Meters			Status	
Label	Value	Label Unit	Label	State
Meter 1	0.00	V	Status 1 OFF	
Meter 2	0.00	V	Status 2 OFF	
Meter 3	0.00	V	Status 3 OFF	
Meter 4	0.00	V	Status 4 OFF	

Label	Relays			State
Relay 1	<input type="button" value="On"/>	<input type="button" value="Off"/>	<input type="button" value="Pulse"/>	
Relay 2	<input type="button" value="On"/>	<input type="button" value="Off"/>	<input type="button" value="Pulse"/>	
Relay 3	<input type="button" value="On"/>	<input type="button" value="Off"/>	<input type="button" value="Pulse"/>	
Relay 4	<input type="button" value="On"/>	<input type="button" value="Off"/>	<input type="button" value="Pulse"/>	

**Silence Sensor**

**Power Ctrl.**  
      **Action**  
      OFF

**Power Failure**

**NOTE:**

The user defined Site ID, Time, Date and Queued Logs are always displayed. Only “admin” level access can edit some of these items

The Monitor/Control page allows the monitoring and/or control of the Site Sentinel™ 4. The following is an explanation of each item on this page:

- Queued Logs: Displays the available number of queued logs.
- Meters: Four metering (analog) channels. The labels, values and units are entered in the I/O setup page.
- Status: Displays the condition of the four status/logic inputs.
- Relays: Allows the user with admin or monitor/control access to control each relay for its displayed function.
- Silence Sensor Level LED’s: Displays the silence sensor input level. The green led operates from -15 and above. The yellow and red led activations are determined by the user programmed trip levels.
- Power Failure: Illuminated when power is applied, OFF when inadequate DC voltage is applied to the PF jack.
- Power Ctrl: Illuminated when the relay is activated.

## Web Setup and Operation

### “User Setup” Web Page

**BROADCAST tools SITE Sentinel™ 4 User Setup**

Site ID:

**NAVIGATION**  
 About  
 Monitor/Control  
 User Setup  
 I/O Setup  
 Email/Network Setup  
 Show Alarms  
 Help  
 Logout

Username	Password	Show Password	--- Access Level ---		
			Admin	Monitor Control	Monitor Only
<input type="text" value="admin"/>	<input type="password" value="...."/>	<input type="checkbox"/>	<input checked="" type="radio"/>	<input type="radio"/>	<input type="radio"/>
<input type="text"/>	<input type="password"/>	<input type="checkbox"/>	<input checked="" type="radio"/>	<input type="radio"/>	<input type="radio"/>
<input type="text"/>	<input type="password"/>	<input type="checkbox"/>	<input checked="" type="radio"/>	<input type="radio"/>	<input type="radio"/>
<input type="text"/>	<input type="password"/>	<input type="checkbox"/>	<input checked="" type="radio"/>	<input type="radio"/>	<input type="radio"/>
<input type="text"/>	<input type="password"/>	<input type="checkbox"/>	<input checked="" type="radio"/>	<input type="radio"/>	<input type="radio"/>
<input type="text"/>	<input type="password"/>	<input type="checkbox"/>	<input checked="" type="radio"/>	<input type="radio"/>	<input type="radio"/>
<input type="text"/>	<input type="password"/>	<input type="checkbox"/>	<input checked="" type="radio"/>	<input type="radio"/>	<input type="radio"/>
<input type="text"/>	<input type="password"/>	<input type="checkbox"/>	<input checked="" type="radio"/>	<input type="radio"/>	<input type="radio"/>

**NOTE:**

After any item has been changed, you MUST press the “Save Settings” button for your changes to be saved.

This page can only be configured with (factory default) the “admin” access level.

**NOTE:** You may view the password by checking the “Show Password” box.

To select other pages (if authorized); make your selection under the left hand Navigation column.

Eight Usernames and Passwords may be configured for up to three access levels.

1. “Admin” allows complete product configuration access.
2. “Monitor/Control” allows the following access:  
 About, Monitor/Control, Show log (unable to clear log), Help, and Logout.
3. “Monitor Only” allows the following access:  
 About, Monitor only, Show log (unable to clear log), Help, and Logout.



## Web Setup and Operation

### “I/O” Setup Page Temperature

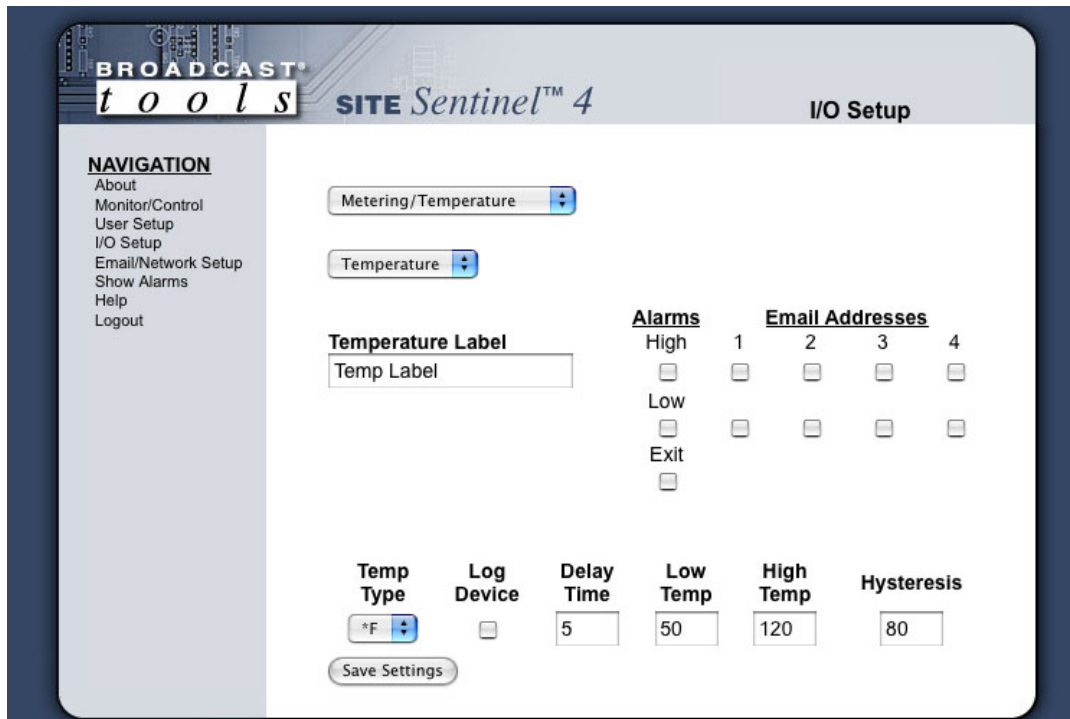

I/O device selection drop-down: Allows the user to select the I/O setup configuration pages.

Metering/Temperature drop-down: Allows the user to select either the temperature or metering inputs to configure.

Temperature Label: Used to identify the temperature probe.

Alarms High: This option enables the “High Temp” email alarms.

Email Addresses: The “High” boxes labeled 1,2,3,4 allows the user to enable up to four different email addresses for high alarms.

Alarms Low: This option enables the “Low Temp” email alarms.

Email Addresses: The “Low” boxes labeled 1,2,3,4 allows the user to enable up to four different email addresses for low alarms.

**WEBSITE:**  
*Visit our web site for product updates and additional information.*

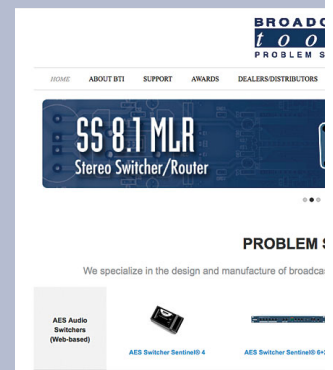

## WEB SETUP

## Web Setup and Operation

### “I/O” Setup Page

#### Temperature

- Alarms Exit:** This option enables the emailing after exiting an alarm.
- Temp Type:** This option specifies what scale will be displayed, Fahrenheit or Centigrade.
- Log Device:** This enables the email logging of temperature.
- Delay Time:** The delay is in (0 to 999) seconds. This option specifies the wait time from when a temperature is out of range before an alarm is activated.
- Low Temp:** This option specifies the LOW temperature alarm set point.
- High Temp:** This option specifies the HIGH temperature alarm set point.
- Hysteresis:** Hysteresis (deadband), This option specifies the hysteresis used when evaluating alarm conditions. Hysteresis prevents alarms from toggling excessively when temperature is at the set point. This is due to normal fluctuation. For example, if the hysteresis is set to 1 degree, and a high alarm is to occur at 91 degrees, the hysteresis ensures that once the high alarm is triggered, it won't go off until the temperature returns to below 91 degrees (90 - 1). This reduces problems with small fluctuations in temperature readings triggering multiple alarms. The hysteresis is also used during low alarm conditions. If, for example, a low alarm is to occur at 43 degrees and the hysteresis is set to 1 degree, then once the low alarm is triggered, it won't go off until the temperature returns to higher than 44 degrees (43 + 1).



#### **NOTE:**

After any item has been changed, you **MUST** press the “Save Settings” button for your changes to be saved.

## Web Setup and Operation

### “I/O” Setup Page Metering

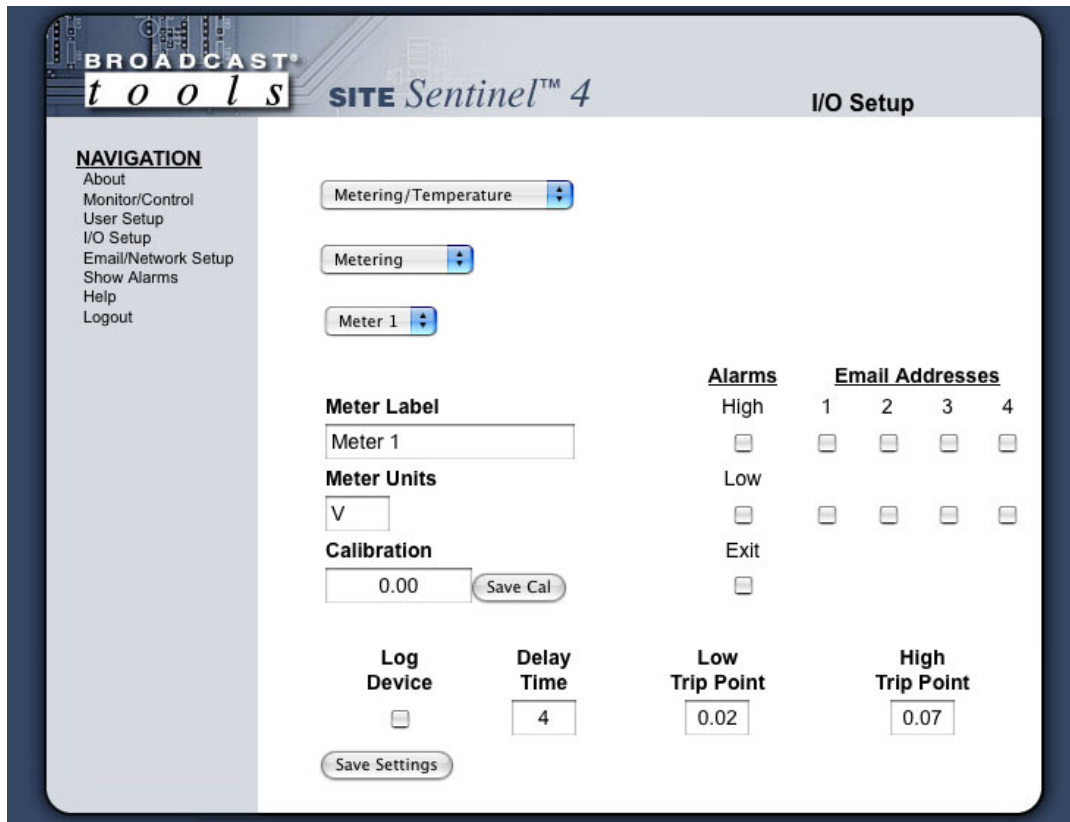

- I/O device selection drop-down: Allows the user to select the I/O setup configuration pages.
- Metering/Temperature drop-down: Allows the user to select either the temperature or metering inputs to configure.
- Metering input selection: Select the metering inputs one thru four for configuration.
- Meter Label: Used to identify the metering input source.
- Metering Units: Label in engineering units, such as V = Volts, A = Amps, W = Watts, etc.
- Calibration: Enter the value of the desired meter reading.

**NOTE:** In order to calibrate, a valid DC sample voltage must be applied to each input. The largest number of digits that may be entered is five.

**NOTE:** The user MUST press the “Save Cal” button in order to store the value.

**WEBSITE:**  
Visit our web site for product updates and additional information.

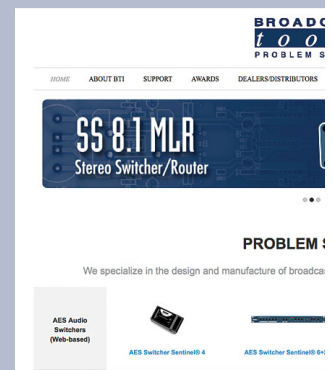

## Web Setup and Operation

### “I/O” Setup Page

#### Metering

- Alarms High:** This option enables the “High Trip Point” email alarm.
- Email Addresses:** The “High” boxes labeled 1,2,3,4 allows the user to enable up to four different email addresses for high alarms.
- Alarms Low:** This option enables the “Low Trip Point” email alarm.
- Email Addresses:** The “Low” boxes labeled 1,2,3,4 allows the user to enable up to four different email addresses for low alarms.
- Alarms Exit:** This option enables the emailing after exiting an alarm.
- Log Device:** This enables the email logging of each metering channel.
- Delay time:** The delay is in (0 to 999) seconds. This option specifies the wait time from when a value is out of range before an alarm is activated.
- Low trip point:** This option specifies the LOW metering alarm set point.
- High trip point:** This option specifies the HIGH metering alarm set point.



#### **NOTE:**

After any item has been changed, you **MUST** press the “Save Settings” button for your changes to be saved.

#### **WEBSITE:**

*Visit our web site for product updates and additional information.*

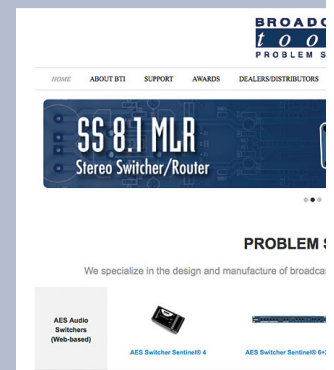

## Web Setup and Operation

### “I/O” Setup Page Status

I/O device selection drop-down: Allows the user to select the I/O setup configuration pages.

Status input selection: Select the status inputs one thru four for configuration.

Input Status Messages: Used to identify the status input source for both an ON or OFF condition.

Alarms OFF: This option enables email alarms of an “ON” status input.

Email Addresses: The “OFF” boxes labeled 1,2,3,4 allows the user to enable up to four different email addresses for off alarms.

## Web Setup and Operation

### “I/O” Setup Page

#### Status

**Alarms ON:** This option enables email alarms of an “OFF” status input.

**Email Addresses:** The “ON” boxes labeled 1,2,3,4 allows the user to enable up to four different email addresses for on alarms.

**Normal Signal Level:** This drop-down allows the selection of current logic level. This is normally set for High, but may be set to low.

**NOTE: When the "Normal signal level" is set to HIGH = NO voltage is applied to the input (WET or no closure when configured for DRY), it's considered OFF, when voltage IS applied (WET or completed closure set to DRY) to the input, it considered ON.**

**NOTE: When the "Normal signal level" is set to LOW = Opposite function of the above description.**

**Log Device:** This enables the email logging of each status channel.

**Delay time:** The delay is in seconds (0 to 99). This option specifies the wait time from when a status/logic input changes state before an alarm is activated.

**Alarm LED:** User defined color of LED on the Monitor and Control page when in an alarm condition.

**NOTE: After any item has been changed, you MUST press the “Save Settings” button for your changes to be saved.**

#### WEBSITE:

*Visit our web site for product updates and additional information.*

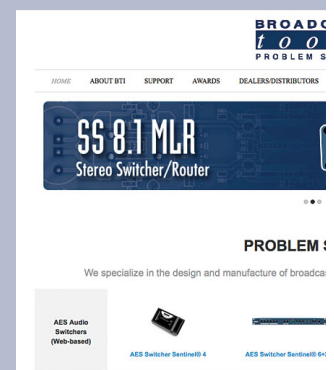

#### WEB SETUP

## Web Setup and Operation

### “I/O” Setup Page Relays 1–4

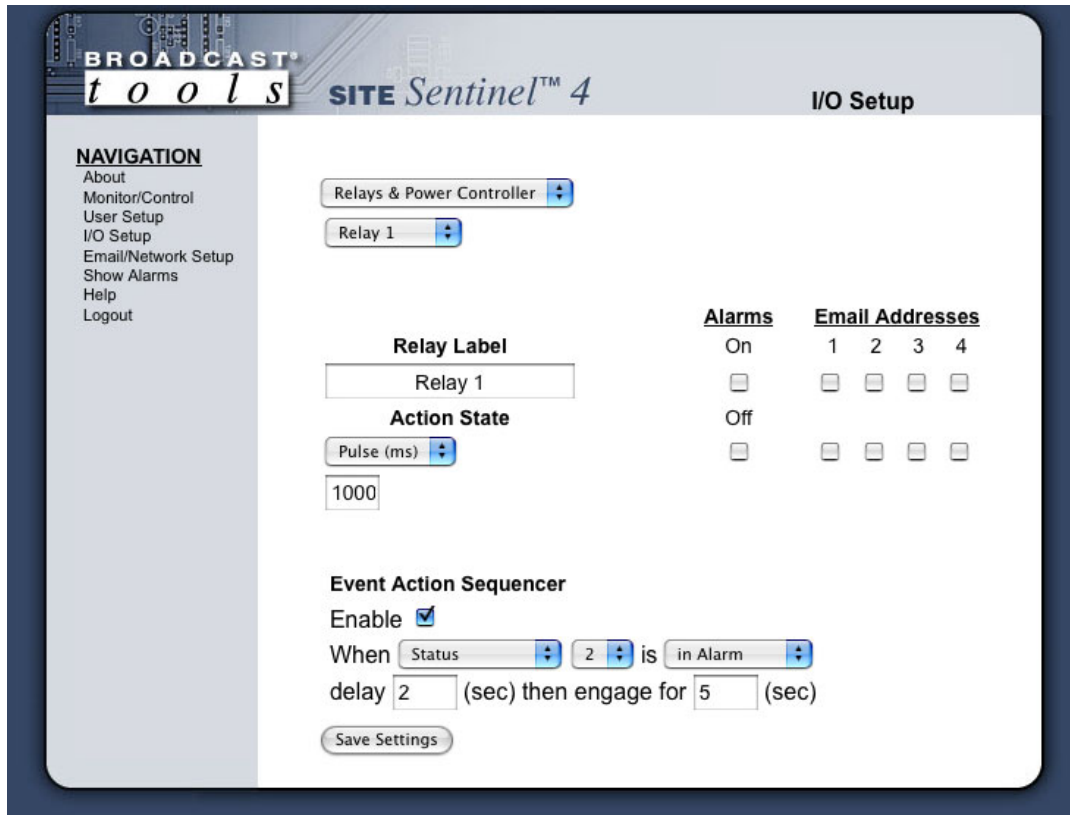

I/O device selection drop-down: Allows the user to select the I/O setup configuration pages.

Relay label: Used to identify the device.

Action/State: Determines how each relay will function. The relays may be configured for one of three states.  
 1 - Independent ON and OFF operation.  
 2 - Pulse with user configured pulse length from 0 to 9999 ms.  
 3 - Toggle (ON/OFF), one button operation.

Alarms OFF: This option enables email alarms with an “ON” relay.

Email Addresses: The “OFF” boxes labeled 1,2,3,4 allows the user to enable up to four different email addresses for off alarms.

## Web Setup and Operation

### “I/O” Setup Page Relays 1–4

Alarms ON:	This option enables email alarms with an “OFF” relay.
Email Addresses:	The “ON” boxes labeled 1,2,3,4 allows the user to enable up to four different email addresses for on alarms.
Event action sequencer:	Used to perform a relay function when parameters are out of tolerance.
Enable:	Enables the selected input to monitor for each relay.
Action:	When (meter, status, silence sensor, power failure or temperature) (input number) is (in ? condition) delay (xx) seconds then engage for (xx) seconds.
Event action sequencer EXAMPLE:	When (meter) (1) is (in High Alarm) delay (1) seconds then engage for (2) seconds.

In the above example: When [metering input] [1] is [in high alarm] for more than [1] second, (the desired relay) then engage for [pulse] 2 seconds.



### NOTE:

After any item has been changed, you **MUST** press the “Save Settings” button for your changes to be saved.

### WEBSITE:

Visit our web site for product updates and additional information.

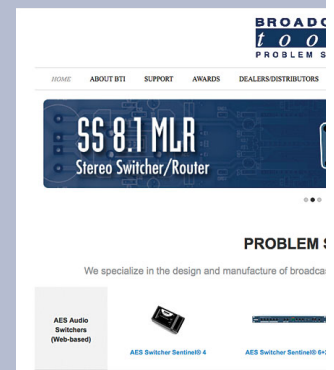



“I/O” Setup Page  
Power Controller

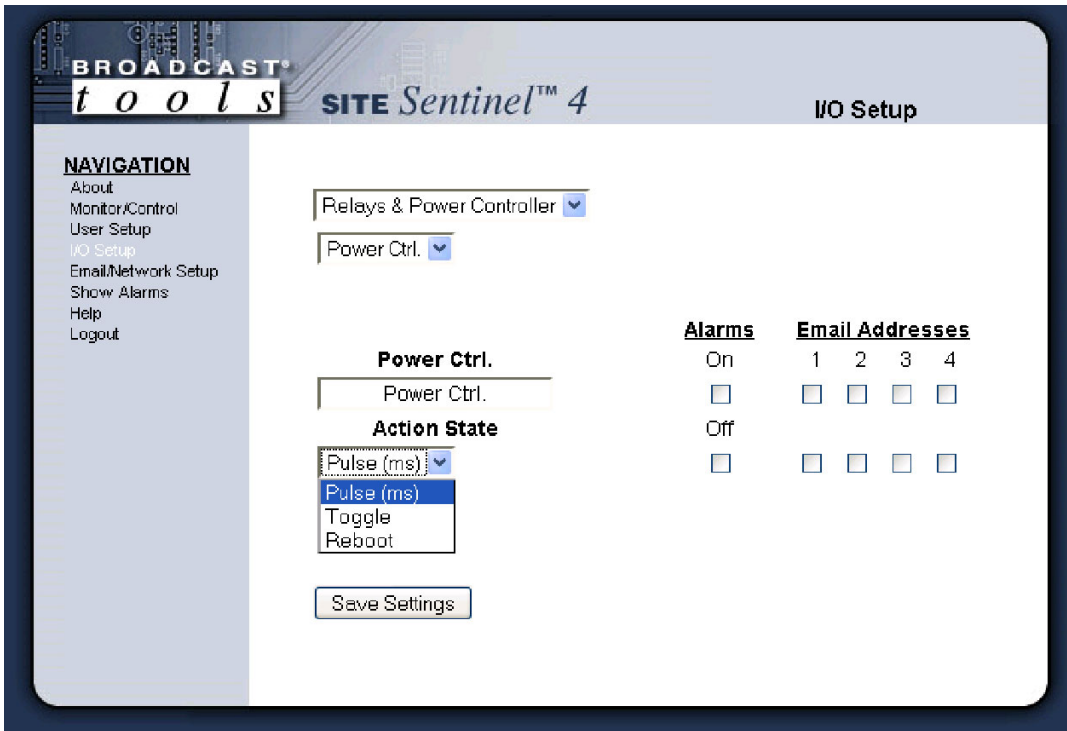

After any item has been changed, you MUST press the “Save Settings” button for your changes to be saved.

**I/O device selection drop-down:** Allows the user to select the I/O setup configuration pages.

**Power Ctrl label:** Used to identify the device.

**Action/State:** Determines how the relay will function. The relay may be configured for one of three states.

1 - Pulse with user configured pulse length from 0 to 9999 ms.

2 - Toggle (ON/OFF), one button operation.

3 – Reboot. One button operation.

**Alarms OFF:** This option enables email alarms with an “ON” relay.

**Email Addresses:** The “OFF” boxes labeled 1,2,3,4 allows the user to enable up to four different email addresses for off alarms.

**Alarms ON:** This option enables email alarms with an “OFF” relay.

**Email Addresses:** The “ON” boxes labeled 1,2,3,4 allows the user to enable up to four different email addresses for on alarms.

“I/O” Setup Page  
Silence Sensor

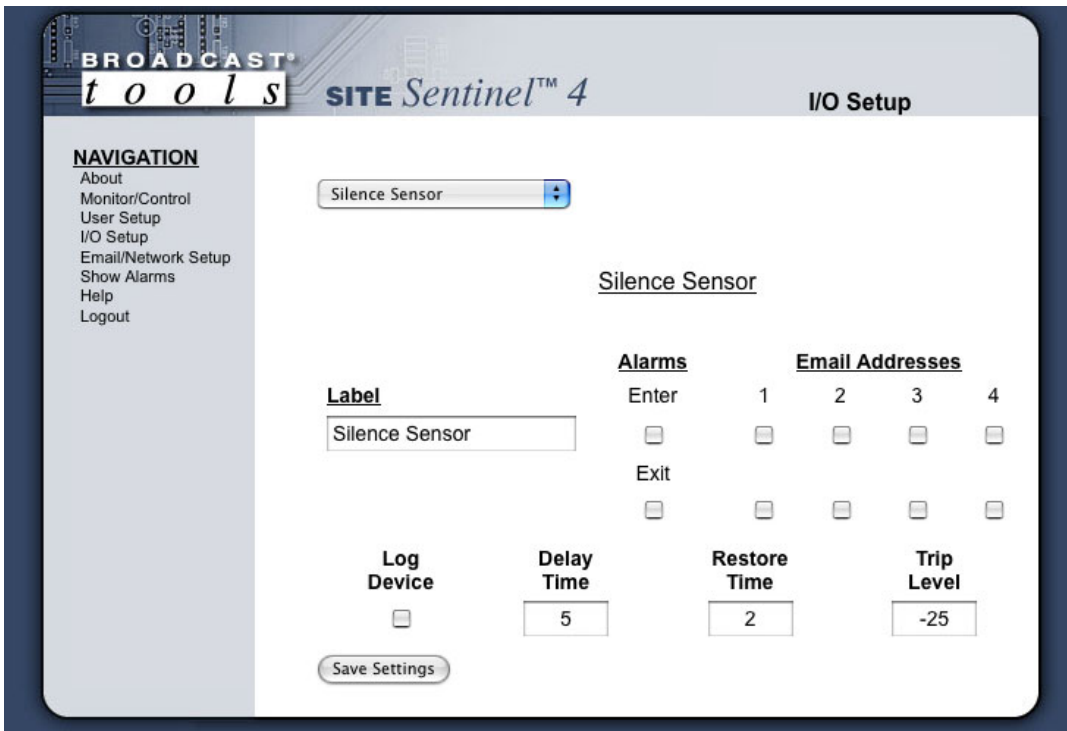

**NOTE:**

After any item has been changed, you **MUST** press the “Save Settings” button for your changes to be saved.

- I/O device selection drop-down: Allows the user to select the I/O setup configuration pages.
- Label: Used to identify the monitoring source.
- Alarms Enter: When checked, generates an email alarm when the silence sensor enters an alarm condition, along with up to four email alarms.
- Email Addresses: The “ENTER” boxes labeled 1,2,3,4 allows the user to enable up to four different email addresses for ENTER alarms.
- Alarms Exit: When checked, generates an email alarm when the silence sensor exits an alarm condition, along with up to four email alarms.
- Email Addresses: The “EXIT” boxes labeled 1,2,3,4 allows the user to enable up to four different email addresses for EXIT alarms.
- Log Device: This enables the email logging of silence sensor status.
- Delay Time (Sec): This is the time 0 (OFF) to 999 seconds (16 minutes, 39 seconds) from when the audio falls below the trip level set in the “Trip Level” box.
- Restore Time (Sec): This is the time 0 (OFF) to 999 seconds (16 minutes, 39 seconds) required for valid audio to be present before the alarm is clear.
- Trip Level (db): The input level at which the audio is considered invalid. This may be set between -25 and -35db below zero reference in 1dB steps.

“I/O” Setup Page  
Power Failure

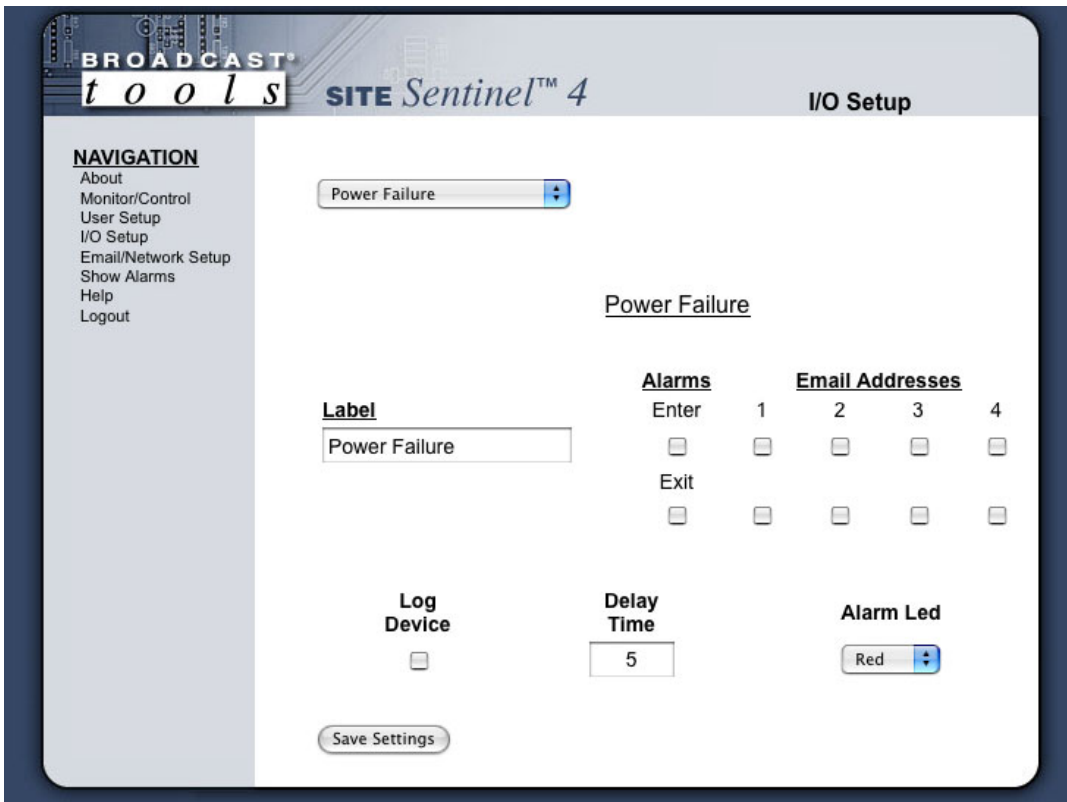

**NOTE:**

After any item has been changed, you **MUST** press the “Save Settings” button for your changes to be saved.

I/O device selection drop-down: Allows the user to select the I/O setup configuration pages.

Label: Used to identify the monitoring source.

Alarms Enter: When checked, generates an email alarm when the PF enters an alarm condition, along with up to four email alarms.

Email Addresses: The “ENTER” boxes labeled 1,2,3,4 allows the user to enable up to four different email addresses for ENTER alarms.

Alarms Exit: When checked, generates an email alarm when the PF exits an alarm condition, along with up to four email alarms.

Email Addresses: The “EXIT” boxes labeled 1,2,3,4 allows the user to enable up to four different email addresses for EXIT alarms.

**WEBSITE:**

*Visit our web site for product updates and additional information.*

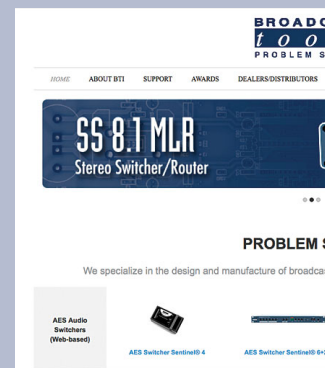

**WEB SETUP**

- Log Device: This enables the email logging of the channel.
- Delay time: The delay is in seconds. This option specifies the wait time from when the power failure input changes state before an alarm is activated.
- Alarm LED: User defined color of LED on the Monitor and Control page when in an alarm condition.

**NOTE: After any item has been changed, you MUST press the “Save Settings” button for your changes to be saved.**

### **Restoring Network Factory Defaults**

**NOTE: The Site Sentinel™ 4 factory defaults may be restored by holding the “Default” button IN, repowering the unit, wait for the SS and PF LED’s to flash, then release the “Default” button.**

## “Scheduler” Setup Page

**BROADCAST TOOLS SITE Sentinel® 4 Scheduler**

Time/Date 11:19:59 8/28/2018

refresh save

Event #	Enable	Event	Device	Frequency	Date type	Date	Time	Next Event	Delete	Execute
1	<input checked="" type="checkbox"/>	Pulse	Relay 1	Repeat	Days/Months	Su-M-T-W-Th-F-Sa Jan-Feb-Mar-Apr-May-Jun-Jul-Aug-Sep-Oct-Nov-Dec	All:28:00	11:28:00 8/28/2018	Delete	Execute
2	<input type="checkbox"/>	Pulse							Delete	Execute
3	<input type="checkbox"/>	Toggle							Delete	Execute
4	<input type="checkbox"/>	Adjust Time							Delete	Execute
5	<input type="checkbox"/>	Enable Alarm							Delete	Execute
	<input type="checkbox"/>	Disable Alarm							Delete	Execute
	<input type="checkbox"/>	Click for new schedule							Delete	Execute

The Scheduler allows for complete control of your Site Sentinel 4 device by providing the ability to schedule when alarms are enabled or disabled, pulse or toggle relays, and even adjust the time for daylight savings.

All 100 schedulable events can also be enabled or disabled; only enabled schedule events are processed. Each schedule event consists of 2 main components, the action to do (event) and when to do it (date/time).

Schedule events are entered in the "Scheduler" menu shown above. Empty/unused schedule slots will have the text "Click for new schedule" listed in the "Event" column. When you select a cell in the scheduler table it will transform into the available options for that cell. Blue colored cells are unselected and are saved while Red colored cells are unselected and are not saved. Yellow colored cells are selected. There can only be one selected cell at a time and changing some cells may change other cells. It is best to work left to right when configuring a schedule event.

To select a cell just click in the cell box and it will transform, the background will be yellow and you should have either drop down boxes or checkboxes to select from. To unselect a cell, click inside the yellow portion of the cell or onto another cell. Clicking on another cell will select that cell, if it can be selected.

At the top and bottom of the "Scheduler" page are "refresh" and "save" buttons. All red cells on the scheduler page are in need of saving and will not be stored or executed until saved. To restore from the previously saved schedules click the "refresh" button.

The last 3 cells of each schedule event are the "Next Event", "Delete", and "Execute" items. "Next Event" lists the date and time that the event is scheduled to occur next. "Delete" will delete the schedule but still requires saving before the change is permanent. "Execute" will execute the action immediately regardless of whether or not it's enabled for scheduled to occur, ensure that you save before executing a schedule since changes are not updated to the Site Sentinel 4 until the save button is pressed.

### NOTE:

*The Scheduler page does not auto refresh, please click “refresh” to update the “Next Event” time.*

### WEBSITE:

*Visit our web site for product updates and additional information.*

Event #	Enable	Event	Device	Freq
1	<input checked="" type="checkbox"/>	Enable Alarm	Metering	
2	<input type="checkbox"/>	Click for new schedule.	Metering	
3	<input type="checkbox"/>	Click for new schedule.	Temperature	
4	<input type="checkbox"/>	Click for new schedule.	Virtual Chan.	
5	<input type="checkbox"/>	Click for new schedule.	Status	
			Relays	
			Internet Down	
			Silence Sensor	
			Power Failure	

**Enable/Disable Alarms:** Alarms for every device that the Site Sentinel 4 monitors can be enabled and disabled by the scheduler. Select the appropriate "Enable Alarm" or "Disable Alarm" from the "Event" drop down box on the Scheduler Setup Page to configure this item. Then from the "Device" drop down box select from monitored device type and its device number.

Event #	Enable	Event	Device	Freq
1	<input checked="" type="checkbox"/>	Pulse	Raise 3	
2	<input type="checkbox"/>	Click for new schedule.	Raise 1	
3	<input type="checkbox"/>	Click for new schedule.	Raise 2	
			Raise 3	
			Raise 4	
			Raise 5	

**Pulse/Toggle:** Relays can be pulsed or toggled from the scheduler. Select "Pulse" or "Toggle" from the "Event" drop down box on the Scheduler Setup Page to configure this item. Then from the "Device" drop down box select the relay you wish to control. The Pulse duration is configured on the "Relay Setup Page" under "I/O Setup".

Event #	Enable	Event	Device	Freq
1	<input checked="" type="checkbox"/>	Adjust Time	-1 Hr	
2	<input type="checkbox"/>	Click for new schedule.	-1 Hr	
3	<input type="checkbox"/>	Click for new schedule.	+1 Hr	

**Adjust Time:** To assist with daylight savings adjustment, the Site Sentinel 4 can add or subtract 1 hour from the time-zone offset. Time-zone offset is initially configured under "Email/Network Setup" and this adjustment will change that value at the scheduled time. Select "Adjust Time" from the "Event" drop down box then from the "Device" drop down box select either "-1 Hr" or "+1 Hr" to decrement or increment the time-zone offset.

**WEBSITE:**

Visit our web site for product updates and additional information.

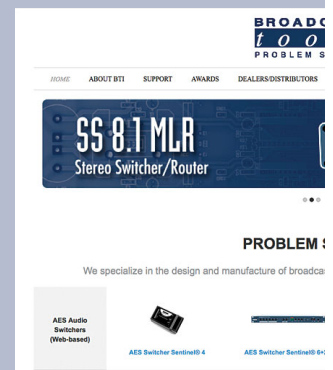

**Configuring Event Time:**

Event #	Enable	Event	Device	Frequency
1	<input checked="" type="checkbox"/>	Pulse	Raise 1	One Time
2	<input type="checkbox"/>	Click for new schedule.		One Time Repeat

**Frequency:** Scheduled events can be initiated either on a repeat or one-time basis. One-time events will be disabled after executing while repeat events will continue to be rescheduled. Select either "Repeat" or "One Time" from the "Frequency" drop down.

Event #	Enable	Event	Device	Frequency	Date Type	Date
1	<input checked="" type="checkbox"/>	Pulse	Raise 1	One Time	Exact Date	Jul 1
2	<input type="checkbox"/>	Click for new schedule.				1
3	<input type="checkbox"/>	Click for new schedule.				2
4	<input type="checkbox"/>	Click for new schedule.				3

**Date:** Selecting when an event occurs can be based on either an exact date (Month/Day) or based on specific days of the week and months in the year. One time events can only be scheduled for an exact date, while repeat events can be scheduled for either exact dates or day/months.

Event #	Enable	Event	Device	Frequency	Date Type	Date
1	<input checked="" type="checkbox"/>	Pulse	Raise 1	Repeat	Days/Months	Su M T W Th F Sa <input type="checkbox"/> <input checked="" type="checkbox"/> <input checked="" type="checkbox"/> <input checked="" type="checkbox"/> <input checked="" type="checkbox"/> <input checked="" type="checkbox"/> <input type="checkbox"/> Jan Feb Mar Apr May Jun Jul Aug Sep Oct Nov Dec <input checked="" type="checkbox"/> <input checked="" type="checkbox"/> <input checked="" type="checkbox"/> <input checked="" type="checkbox"/> <input checked="" type="checkbox"/> <input checked="" type="checkbox"/> <input checked="" type="checkbox"/> <input checked="" type="checkbox"/> <input checked="" type="checkbox"/> <input checked="" type="checkbox"/> <input checked="" type="checkbox"/> <input checked="" type="checkbox"/>

To select the Date for an "Exact Date" type choose the month and day from the two drop down boxes under "Date".

To select the date for a "Day/Months" type choose the months and days of the week by checking the checkboxes under "Date" for the days of the week and months of the year that you want this event to happen.

Event #	Enable	Event	Device	Frequency	Date Type	Date	Time
1	<input checked="" type="checkbox"/>	Pulse	Raise 1	Repeat	Days/Months	M-T-W-Th-F Jan-Feb-Mar-Apr-May-Jun-Jul-Aug-Sep-Oct-Nov-Dec	Hr Min Sec 8 20 0

**Time:** Selecting the time of day an event occurs is accomplished using the "Time" column. Hours are referenced as Military Time and include 0-23 as well as "All Hours". When "All Hours" is selected the event will be scheduled for all hours on the day it is schedule to execute, otherwise it is only scheduled for the specific hour. Events can also be configured to execute at a specific minute and second, though no "All Hours" options exist for minutes and seconds.

**WEBSITE:**  
 Visit our web site for product updates and additional information.

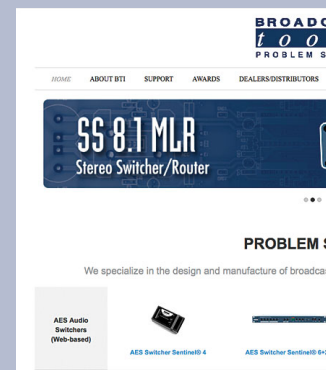

**INSTALLATION**

## Web Setup and Operation

### “Email/Network Setup” Web Page

BROADCAST  
tools

SITE Sentinel™ 4

Email / Network Setup

**NAVIGATION**

- About
- Monitor/Control
- User Setup
- I/O Setup
- Email/Network Setup
- Show Alarms
- Help
- Logout

Device Address

Device Netmask

Gateway Address

DNS Server Address

HTTP Port

SMTP Server Address

SMTP Port

SMTP Return Address

SMTP Host ID

SMTP Authentication

SMTP Username

SMTP Password

show password

Logging Email Address

Update Interval (Hours)

Email Alarms

Daily Alarm Email Time (Hour)

Recipient Addresses

1

2

3

4

SNMP Manager IP Address

SNMP Manager Trap Port

SNMP Read Community

SNMP Write Community

SNMP Enable Traps

NTP Server Address

NTP Port

NTP Update Interval (Minutes)

NTP Enabled

Site ID

Monitor Refresh Time  Seconds

Time Zone Offset from UTC

Enable Event Logging

Login

Email

Reboot

Alarms Cleared

**WEBSITE:**  
*Visit our web site for product updates and additional information.*

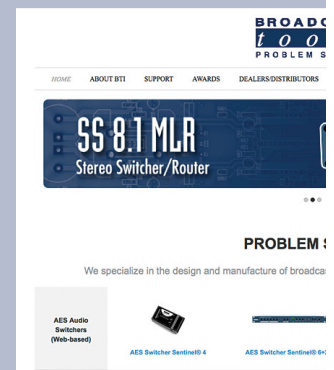

## WEB SETUP



## Web Setup and Operation

### “Email/Network Setup” Web Page

Device Address: Enter a static IP address here. Default: 192.168.1.55

Device Netmask: Enter the Netmask here: Default: 255.255.255.0

Gateway Address: Enter the Gateway IP here: Default: 192.168.1.1

DNS Server IP Address: Enter your DNS address here. Default: 192.168.1.1

HTTP Port: Normally Port 80 Default: 80

SMTP Server Address: The user can enter either an IP address in the xxx.xxx.xxx.xxx format or a URI in the form: smtp.comcast.net. In order to resolve the URI, a working DNS server must be present or its IP address entered into the system.

SMTP Port: Normally Port 25 Default: 25

SMTP Return Address: Enter your return email here. If an email cannot be delivered, a message stating why will be sent to this address.

**NOTE: The user must enter the following items before an email can be successfully sent: SMTP Server Address, SMTP Port, SMTP Return Address, SMTP Host ID, SMTP username and SMTP password must be supplied if authentication is turned on and Recipient Address 1. The test email is sent to email recipient address 1.**

The user should press the “Save Settings” button after entering the SMTP information before attempting an email test. If authentication fails, the email is not sent, please ensure that the username and password is correct.

SMTP Host ID: Enter something here to identify the device.

SMTP Authentication: When checked, Base64 SMTP authentication is supported by clicking on the checkbox.

SMTP Username: Enter user name here.

SMTP Password: Enter password here.

Logging Email Address: IP address for the “Logging” email recipient (may be different from the four “Alarm” Recipient Addresses. Logging emails and Daily emails are sent to this address. Update Interval (Hours): This determines how often an update email is sent. Only devices enabled for logging will be included in this email. If set to 0 (zero), no logging email will be sent. Default: 0

## “Email/Network Setup” Web Page

“Alarm” Recipient Address: Email Recipient 1, Email Recipient 2, Email Recipient 3, Email Recipient 4

SNMP Manager IP Address: This is the IP address of the SNMP manager. The system only accepts SNMP requests from this IP address, and will send traps to this IP address only.

SNMP Manager Trap Port: This is the port number that SNMP trap messages will be sent.

SNMP Read Community: This is the community name for Read-Only access.

SNMP Write Community: This is the community name for Read-Write access.

SNMP Enable Traps: When checked, trap messages will be sent. When Unchecked, no trap messages will be sent.

**NOTE: A cold-start trap will be sent when the unit boots up if the SNMP Enable Traps is checked, otherwise trap messages are sent based on the device and enabled alarms.**

NTP (Time) Server Address: Enter the NTP address here. Default: pool.ntp.org

NTP Port: Normally 123. Default: 123

NTP Update Interval (Min): Time between timing updates. Default: 30

NTP Enabled: Must be enabled for correct timing. Default: Enabled

Site ID: This is the Site Identifier that will be sent in each email.

Monitor Refresh Time (Sec): How many seconds the Monitor page refreshes. Shorter times may increase network traffic.

Time Zone Offset from UTC: Must be set for correct timing. Default: -8

Enable Event Logging: Enabling these checkboxes will generate an alarm, but will not send an email. If the system is configured for Daily Alarm emails, then that Daily Alarm email will contain the Event Logging items as well.

Login: Whenever someone logs into the system, the username and date/time will be logged.

Email: Whenever an email is sent, the type of email and date/time will be logged.

## WEBSITE:

Visit our web site for product updates and additional information.

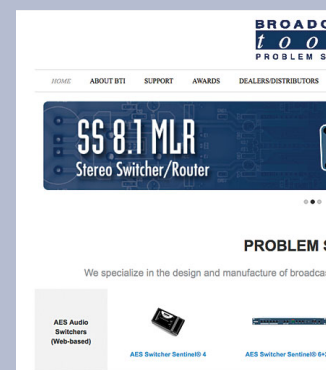

## WEB SETUP

## “Email/Network Setup” Web Page

- Reboot:** Whenever the device boots, the date/time will be logged.
- Alarms Cleared:** Whenever the Daily Logs or Normal Alarms are cleared, the type of log cleared and date/time will be stored. When Daily Logs are sent, the Daily Logs are also cleared; this will cause an event log as well.
- Save Settings:** After pressing the “Save Settings” button, the device will reboot (If you changed the IP address, you must navigate your web browser to the new IP address (if the HTTP port was changed from port 80, be sure to add the new port number after the IP: xxx.xxx.xxx.xxx:port #). If you didn’t change the IP address, then the web page will return to the login screen after the device reboots.
- Reboot Device:** When you press the “Reboot Device” button, the device resets, you must navigate your web browser to the new IP address.
- Send Test Email:** Press this button to send a test email. When the email has completed an alert box will pop-up indicating the status of the email and an error condition if the email was not sent correctly. If an email was not sent correctly please review your SMTP settings and correct as necessary.

**NOTE: After you are done making changes to the Email/Network Setup page, you MUST press the “Save Settings” button to save your changes.**

- Reload Defaults:** When you press the “Reload Defaults” button, the device resets, you must navigate your web browser to the new IP address (if the HTTP port was changed from port 80, be sure to add the new port number after the IP: xxx.xxx.xxx.xxx:port #).
- Clear Daily Logs:** When you press the “Clear Daily Logs” button, the daily logs stored in memory will be cleared. Keep in mind that if the Alarms Cleared Event is enabled, this event will post after the logs are cleared.
- Send Daily Logs:** When you press the “Send Daily Logs” button, the system will send the daily logs email and then clear those logs as if the correct time has expired.

## “Show Log” Web Page

This page displays current alarms.

Device	Enter/Exit	Date	Time
No Currently Saved Alarms			
Last Updated 11/11/2009 14:20:06			

Device : Displays which device and/or devices triggered the alarm.

Enter/Exit: Displays if the alarm is entering or exiting an alarm condition.

Date: Displays what date the alarm was logged.

Time: Displays what time the alarm was logged.

**NOTE: With the “admin” access level, the user may control all functions.**

With the “Monitor/Control” or “Monitor” only access level, the user may view the “Show Log”, enable/disable PC speaker sound and silence alarms.

**NOTE: Shock Wave “Flash” must be installed and operating properly on your PC for the “Alarm Sound” to work when enabled.**

## “About” Web Page

The “About” Web Page displays the product name, firmware version numbers, and Broadcast Tools® Web site link.

**BROADCAST tools** SITE Sentinel™ 4 About

**NAVIGATION**  
About  
Monitor/Control  
User Setup  
I/O Setup  
Email/Network Setup  
Show Alarms  
Help  
Logout

**Broadcast Tools, Inc.**

<b>Device Name</b>	Site Sentinel 4
<b>Firmware Version</b>	SS4X_V1.22
<b>PIC Firmware Version</b>	SS4P_V1.03
<b>Web page Version</b>	SS4W_V1.23
<b>Home page</b>	<a href="http://www.BroadcastTools.com">www.BroadcastTools.com</a>

## WEBSITE:

*Visit our web site for product updates and additional information.*

**BROADCAST tools** PROBLEMS

HOME ABOUT BTI SUPPORT AWARDS DEALERS/DISTRIBUTORS

**SS 8.1 MLR**  
Stereo Switcher/Router

**PROBLEM ?**  
We specialize in the design and manufacture of broadcast

AES Audio Switchers (Web-based)  
AES Switcher Sentinel® 4  
AES Switcher Sentinel® 8x

## Specifications

Ethernet Interface:	RJ-45, 10Base-T or 100Base-TX, auto sensing with Link & activity indicator - Full/half duplex.
Control Logic:	Micro with non-volatile memory and web server.
Temperature Sensor:	Probe (optional) with 25-foot cable and 3.5mm T/R/S plug. -67°F to +257°F (-55°C TO +125°C).
Silence Sensor:	Stereo unbalanced 22K ohm inputs. Input level: -10dBu to +24dBu. Note: Summed to monaural.
Control Relays:	Four SPST normally open dry contacts, 30 VDC @1 Amp.
Power Controller Relay:	SPDT dry contacts. 30 VDC @ 1 amp. <b>CAUTION! For safety, never connect 120 Vac circuits to these relays!</b>
Metering (analog) inputs:	Four - Buffered single ended (ground referenced) 0 to 10 VDC input range. 45 K ohm input Z. 10-bit resolution.
Status/Logic inputs:	Four - Optically Isolated. Internal jumpers for (WET), floating) external 5 to 24 VDC or internal 5 VDC source (DRY). Open collector, contact closures to ground or external logic source.
Power Failure input:	Optically-isolated, 5 to 12 VDC @ 15 ma, center positive. 2.1mm x 5.5mm coax type.
Connectors:	Metering (analog), status, relays and silence sensor audio input: Removable euroblock screw terminals, 2 x 2.1mm x 5.5mm coax type power jacks and 1/8" T/R/S mini-jack temp probe.
EMI / FCC Compliance:	See the Declaration of Conformity page. Operation is subject to the following two conditions: 1) This device may not cause harmful interference, and 2) this device must accept any interference received, including that which may cause undesired operation.
Protocols:	TCP/IP, UDP/IP, ARP, ICMP, SNMP, TFTP, Telnet, DHCP, BOOTP, HTTP, and AutoIP.
Required power supply:	7.5 VDC only @ 1 amp. 2.1mm ID x 5.5mm OD coaxial connector, center positive. Surge protected. Domestic PS supplied.
Size:	5.65" x 6.00" x 1.55", painted aluminum chassis w/ 4 - 6-32 mounting holes.
Weight:	2.0 lb.
Options:	* CE certified 240 VAC power supply. * RA-1, 1-RU rack shelf. Accommodates 3 units. * LR-5, 5-pole mechanical latching relay.

## WEBSITE:

*Visit our web site for product updates and additional information.*

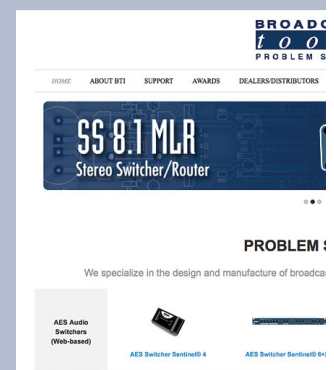

## SPECIFICATIONS

## LIMITED WARRANTY

The term “Buyer” as used in this document refers to and includes both (but only) (a) any person or entity who acquires such an item for the purpose of resale to others (i.e., a dealer or distributor of an item), and (b) the first person or entity who acquires such an item for such person’s or entity’s own use.

Broadcast Tools warrants to each Buyer of any item manufactured by Broadcast Tools that the item will be free from defects in materials and workmanship at the time it is shipped by Broadcast Tools if the item is properly installed, used and maintained.

## EXCLUSIVE REMEDIES

If Broadcast Tools is notified, in writing, of a failure of any item manufactured by Broadcast Tools to conform to the foregoing Limited Warranty within one (1) year following the date of the Buyer’s acquisition of the item, and if the item is returned to Broadcast Tools in accordance with Broadcast Tools’ instructions for confirmation by inspection of the defect (which at Broadcast Tools’ election may include, without limitation, a requirement that the Buyer first obtain a Return Authorization number from Broadcast Tools, that the Buyer furnish proof of purchase in the form of an invoice and/or receipt, and that the Buyer prepay all freight charges associated with any return of the item to Broadcast Tools using such freight service as Broadcast Tools reasonably may specify), Broadcast Tools will repair or replace the defective item, or will refund the purchase price paid by the Buyer for the item. Broadcast Tools shall have the exclusive right to choose between these alternative remedies.

## NO OTHER WARRANTIES OR REMEDIES

TO THE MAXIMUM EXTENT PERMITTED BY APPLICABLE LAW, BROADCAST TOOLS AND ITS SUPPLIERS DISCLAIM ALL OTHER WARRANTIES, EITHER EXPRESS OR IMPLIED, INCLUDING BUT NOT LIMITED TO IMPLIED WARRANTIES OF MERCHANTABILITY OR FITNESS FOR A PARTICULAR PURPOSE; AND THE FOREGOING ALTERNATIVE REMEDIES SHALL BE EXCLUSIVE OF ALL OTHER REMEDIES. THIS LIMITED WARRANTY GIVES YOU SPECIFIC LEGAL RIGHTS. YOU MAY HAVE OTHER RIGHTS, WHICH VARY FROM STATE/JURISDICTION TO STATE/JURISDICTION.

## NO LIABILITY FOR CONSEQUENTIAL DAMAGES

TO THE MAXIMUM EXTENT PERMITTED BY APPLICABLE LAW, NEITHER BROADCAST TOOLS NOR ANY OF ITS SUPPLIERS SHALL HAVE ANY LIABILITY FOR ANY SPECIAL, INCIDENTAL, INDIRECT, CONSEQUENTIAL OR PUNITIVE DAMAGES WHATSOEVER (INCLUDING, WITHOUT LIMITATION, ANY DAMAGES FOR LOST PROFITS, BUSINESS INTERRUPTION, LOSS OF DATA OR INFORMATION, COST OF CAPITAL, CLAIMS OF CUSTOMERS, OR ANY OTHER PECUNIARY LOSS) ARISING OUT OF THE USE OF OR THE INABILITY TO USE ANY ITEM SUPPLIED BY BROADCAST TOOLS, EVEN IF BROADCAST TOOLS HAS BEEN ADVISED OF THE POSSIBILITY OF SUCH DAMAGES HAVE ANY LIABILITY FOR ANY SPECIAL, INCIDENTAL, CONSEQUENTIAL, EXEMPLARY OR PUNITIVE DAMAGES. THIS LIMITATION OF LIABILITY APPLIES WHETHER A CLAIM IS ONE ALLEGING BREACH OF A CONTRACT OR WARRANTY, NEGLIGENCE OR OTHER TORT, FOR THE VIOLATION OF ANY STATUTORY DUTY, THE FAILURE OF ANY LIMITED OR EXCLUSIVE REMEDY TO ACHIEVE ITS ESSENTIAL PURPOSE, OR ANY OTHER CLAIM OF ANY NATURE. BECAUSE SOME STATES AND JURISDICTIONS DO NOT ALLOW THE EXCLUSION OR LIMITATION OF LIABILITY FOR INCIDENTAL OR CONSEQUENTIAL DAMAGES, THIS LIMITATION MAY NOT APPLY TO YOU.

### **Broadcast Tools, Inc.**

131 State Street

Sedro-Woolley, WA 98284 • USA

360.854.9559 **voice** • 866.783.1742 **fax**

support@broadcasttools.com **e-mail**

www.broadcasttools.com **website**

## Declaration of Conformity

The XPORT Device contained in the Site Sentinel™ 4 conforms to the following standards: (according to ISO/IEC Guide 22 and EN 45014)

### **Manufacturer's Name & Address:**

Site Sentinel™ 4:  
Broadcast Tools, Inc.  
131 State Street.  
Sedro Woolley, WA 98284-1503 USA

### **XPORT:**

Lantronix 15353 Barranca Parkway, Irvine, CA 92618 USA  
Declares that the following product:

Product Name Model: XPORT™ Device Server

Conforms to the following standards or other normative documents:

### **Electromagnetic Emissions:**

EN55022: 1998 (IEC/CSP1R22: 1993) Radiated RF emissions, 30MHz-1000MHz  
Conducted RF Emissions – Telecom Lines – 150KHz - 30MHz  
FCC Part 15, Subpart B, Class B  
IEC 1000-3-2/A14: 2000  
IEC 1000-3-3: 1994

### **Electromagnetic Immunity:**

EN55024: 1998 Information Technology Equipment-Immunity Characteristics  
Direct ESD, Contact Discharge  
Indirect ESD  
Radiated RF Electromagnetic Field Test  
Electrical Fast Transient/Burst Immunity  
RF Common Mode Conducted Susceptibility  
Power Frequency Magnetic Field Test

### **Manufacturer's Contact:**

Site Sentinel™ 4  
Broadcast Tools, Inc.  
131 State Street  
Sedro Woolley, WA 98284-1503 USA  
Tel: 360.854.0608 Fax: 866.783.1742

### **XPORT**

#### **Lantronix:**

Director of Quality Assurance  
15353 Barranca Parkway, Irvine, CA 92618 USA  
Tel: 949.453.3990 Fax: 949.453.3995

### **WEBSITE:**

*Visit our web site for product updates and additional information.*

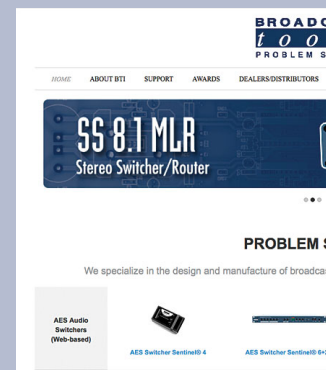

## DECLARATION



### Fractional Schematic

Temp Probe Input (Temperature Probe Optional)

PCJP  
PCNC  
PCNO

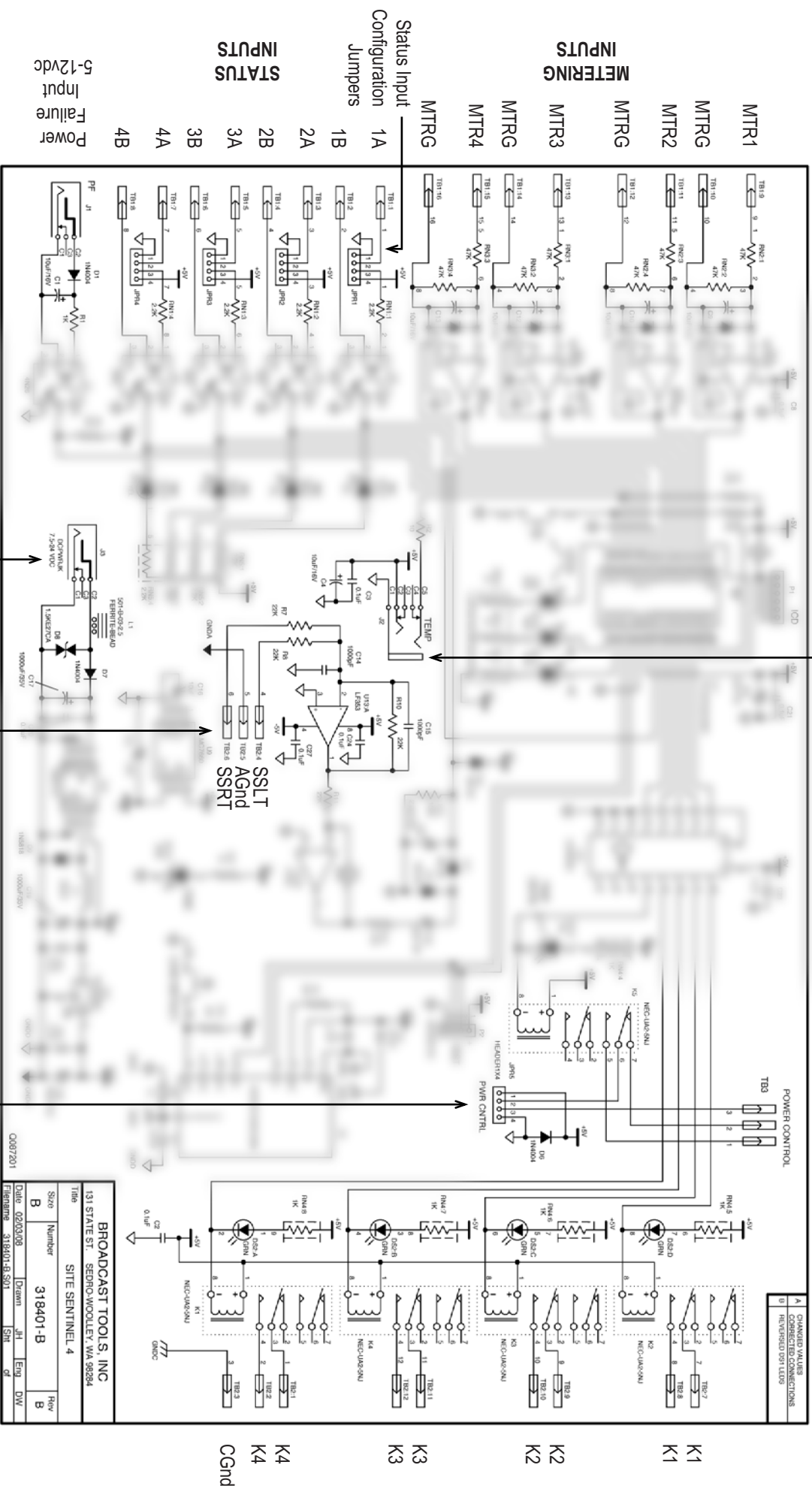

A	CHANGED VALUES
B	CORRECTED CONNECTIONS
	REVERSED 091T LEADS

BROADCAST TOOLS, INC	
131 STATE ST. SEDRO-WOLLEY, WA 98284	
Title	SITE SENTINEL 4
Size	Number
B	318401-B
Date	02/03/08
Filename	318401-B-S01
Drawn	JH
Eng	DW
Shr	d

Power 7.5VDC  
Unbalanced Stereo Silence  
Sensor Input (-10dbu - +24dbu)  
Power Controller  
Configuration Jumper

# Site Sentinel® 4

## Jumper Layout

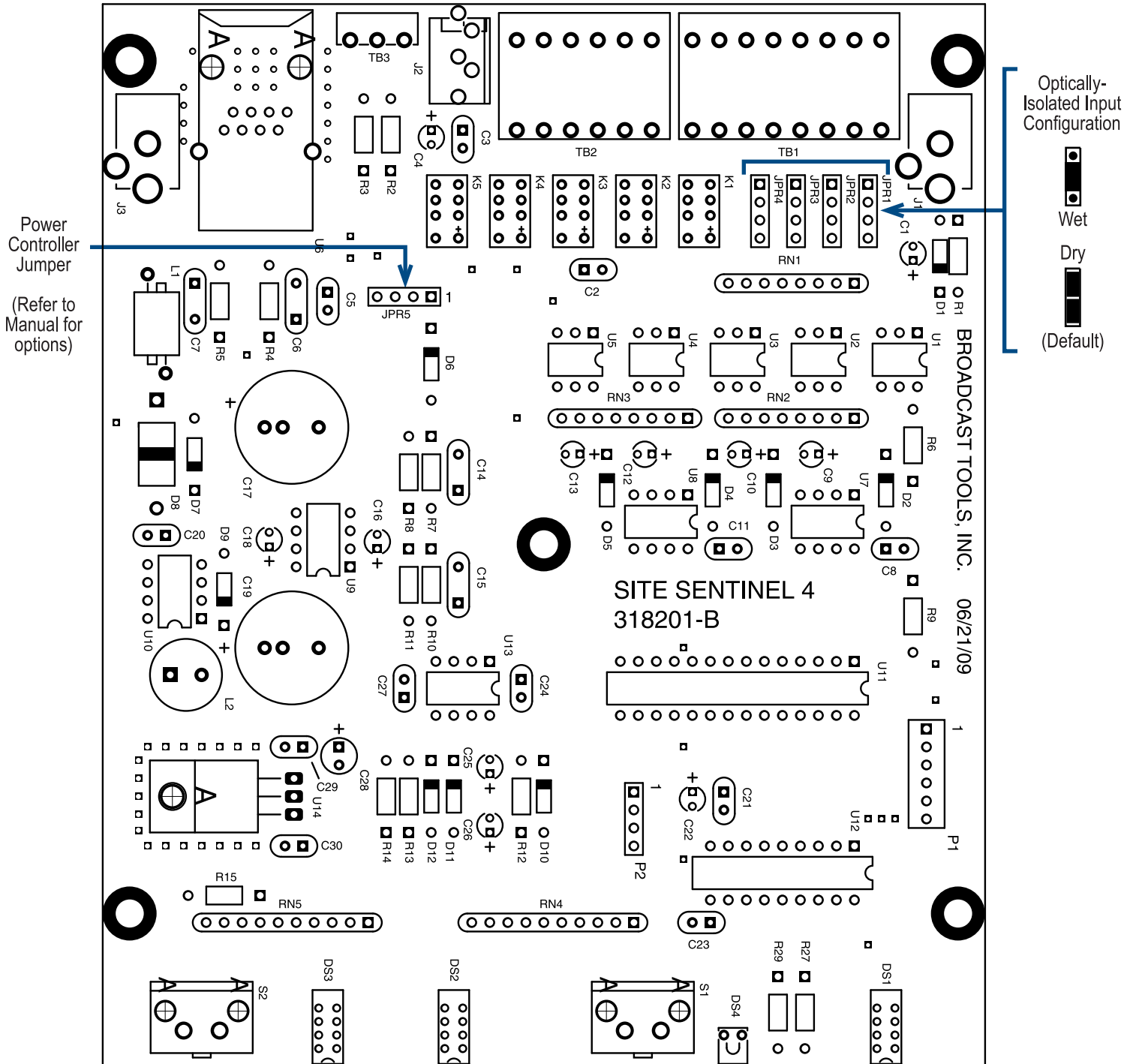

Front and Rear Chassis

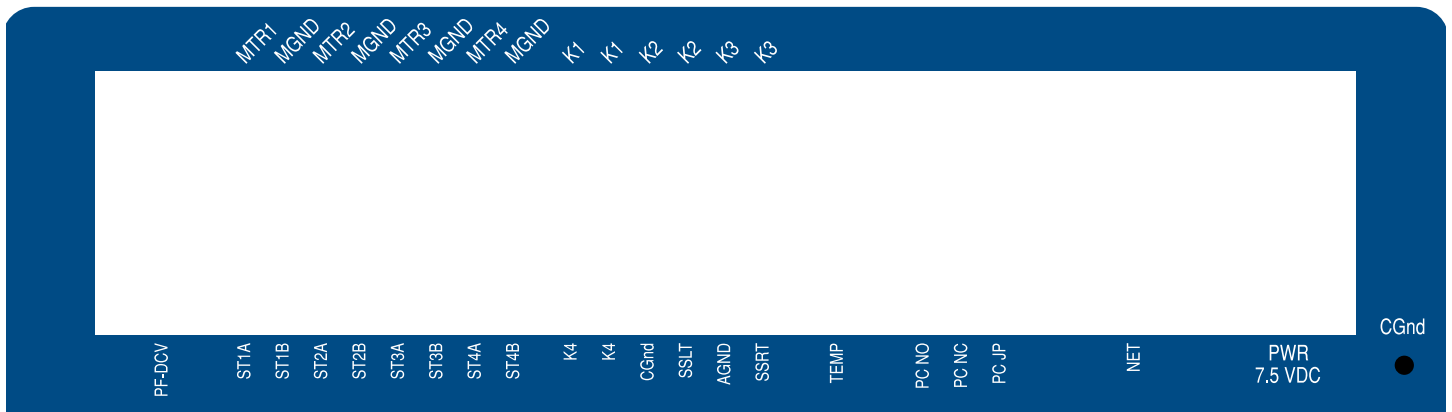
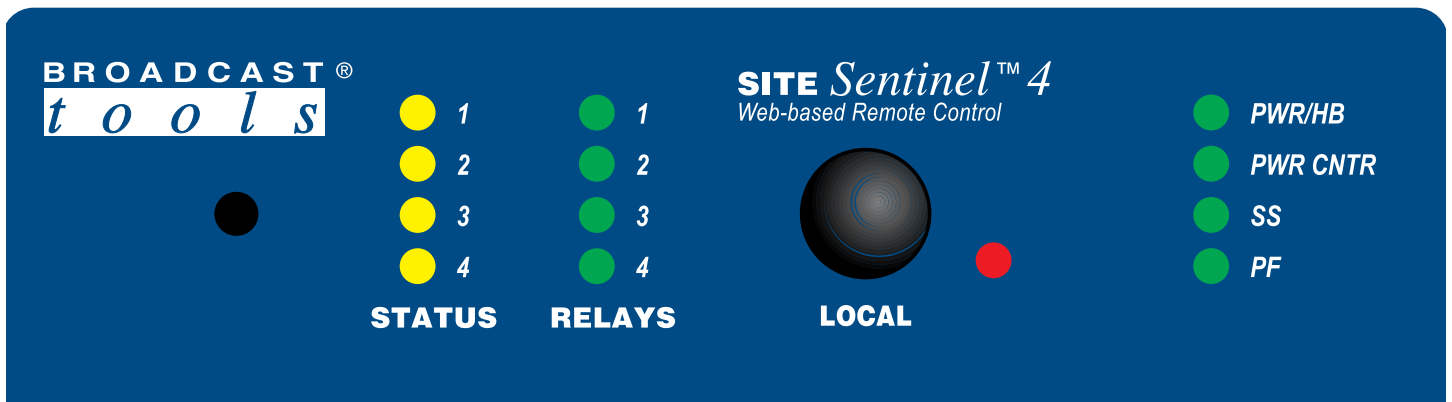

### Functional Diagram

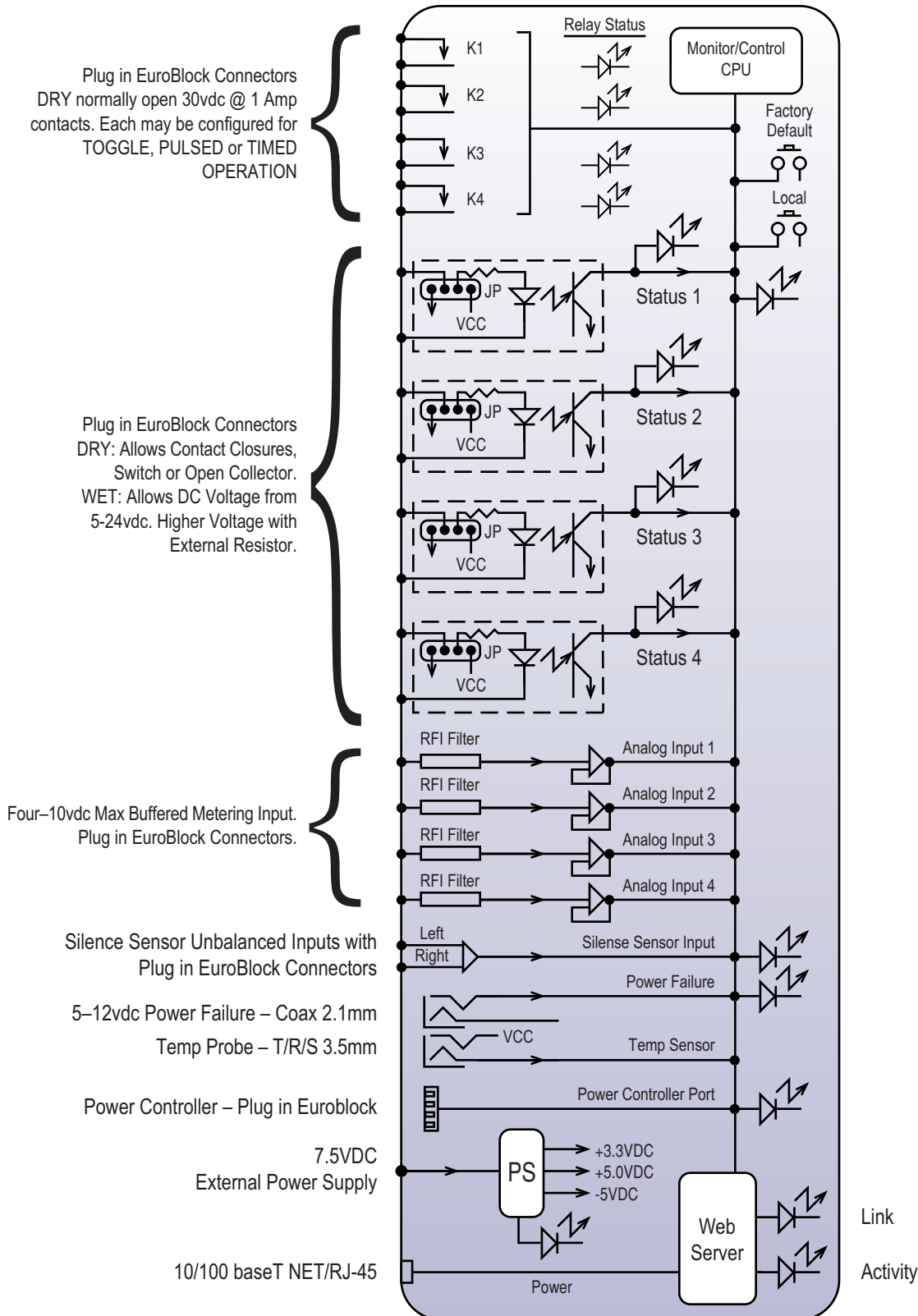

# Typical Sentinel® Product I/O

## STATUS INPUT "DRY"

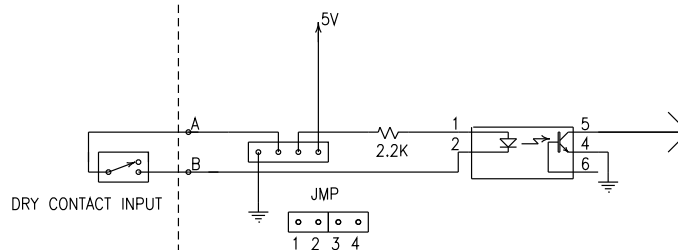

## STATUS INPUT "DRY"

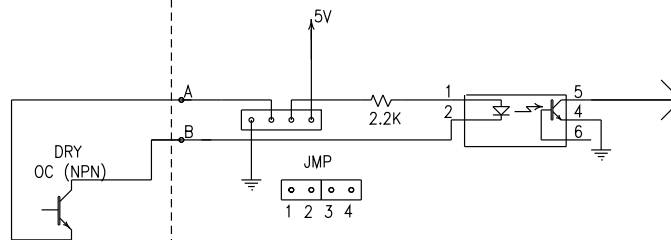

## STATUS INPUT "WET"

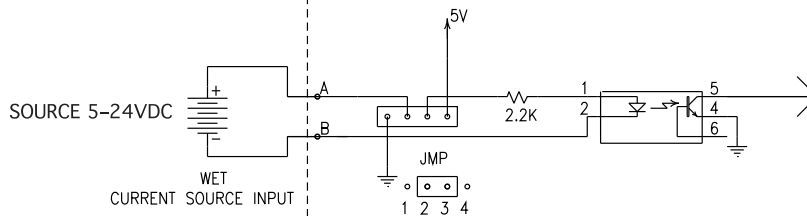

## ANALOG INPUT

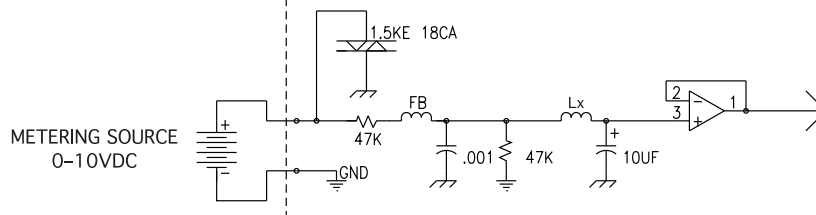

## RELAY OUTPUTS

