

# MS-702 Two-Channel Main Station

Analog Partyline Solutions

Linking  
People  
Together



MS-702

## Key Features

- Supports up to 55 beltpacks or 10 speaker stations on two channels
- Separate short-circuit protection for each channel
- Dual-action electronic momentary/latching Talk buttons
- Program feed to both channels, with selectable Program Interrupt (IFB)
- Call signal buttons for each channel
- Remote Mic Kill
- Announce output with relay
- Microphone limiting
- Volume controls for each channel
- Visual and audible Tone Alert signaling
- Channels A & B Link switch
- Built-in speaker
- External switchable line termination on each channel
- Universal voltage power supply

Clear-Com Encore® is a 2-wire analog partyline system with intuitive plug-and-play design and superior “Clear-Com Sound.”

## Description

The MS-702 is a 1RU two-channel main station with programmable front panel buttons, individual channel short-circuit protection, individual channel volume control, and a regulated fail-safe power supply. The MS-702 supports up to 55 beltpacks or 10 speaker stations.

## Monitoring System

The MS-702 can monitor intercom activity on one or both channels with individual listen-level controls. Monitoring intercom activity is possible through a headset or the internal loudspeaker.

## Talk Selection

The MS-702 has mic pre-amps with limiters and speech-shaping circuits. An individual electronic momentary/latching Talk button is available for each channel. Illuminated dual-action Talk buttons light an LED dimly when latched: blue-color while in standby, amber-color when latched. The latching feature can be disabled. The channels can be accessed separately or simultaneously without tying them together. A selector switch toggles between the headset or microphone. The Talk buttons can also be controlled with a footswitch.

## Announce Output

For paging, the MS-702 provides a balanced, line-level output signal to a 1/4-inch TRS connector on the rear panel. The front panel Announce button activates the output and the Announce relay. The relay circuit, on a separate 1/4-inch TRS connector, is typically used to mute monitors.

## Call Signaling

The MS-702 has individual Call buttons with visual call signaling for each channel on the partyline. The visual signal will flash brightly and will emit an audible signal if the remote station operator holds the Call button for more than 2 seconds. The call signaling feature can be programmed to the Talk buttons.

## Remote Mic Kill (RMK)

The MS-702 has a global Remote Mic Kill button. It will turn on the microphone talk circuits of all beltpacks on the system, eliminating extraneous noise from the open headset microphones.

# MS-702 Two-Channel Main Station

Analog Partyline Solutions

## Program Input and Interrupt (IFB)

The MS-702 accepts a line-level external program input for monitoring in the headset and speaker, and/or mixing with intercom audio on either or both channels. When Interrupt is selected, the program signal is interrupted when the Talk button is pressed.

## Power

The MS-702 has a visual indication of power supply conditions. In the event of a short circuit or current overload on a channel, that channel will shut down while the other one continues to operate. As soon as the fault condition is removed, the auto-reset circuitry will restore power to that channel, even under full-load conditions.

## Technical Specifications

dBu is an absolute measurement. 0dBu is referenced to 0.775 volts RMS

### Station Capacity

Up to 55 RS-701 beltpacks or 10 speaker stations or 12 headset stations distributed over both channels

### Panel Microphone Input

**Input Type:** Electret  
**Input Impedance:**  $\geq 2K$   
**Mic Limiter Threshold:** 0dBu  $\pm 3$ dB  
**Mic Limiter Range:**  $\geq 20$ dB

### Headset Microphone Input

**Input Type:** Dynamic  
**Input Impedance:**  $\geq 1K$   
**Mic Limiter Threshold:** 0dBu  $\pm 3$ dB  
**Mic Limiter Range:**  $\geq 15$ dB

### Program Line Input

**Maximum Level before Clipping:**  $\geq 20$ dBu  
**Input Impedance:**  $\geq 5K$

### Headset Output

**Load Impedance:**  $\geq 8$   
**Output Impedance:**  $\leq 25$   
**Output Limiter Threshold:** +5dBu  $\pm 3$ dB  
**Maximum Output Level before Distortion:**  $\geq 17$ dBu

### Speaker Output

**Load Impedance:**  $\geq 4$   
**Max Output Level before 1% Distortion:** 20dBu  $\pm 2$ dBu

### Partyline Output

**O Noise:**  $< -74$ dBu  
**Output Impedance:**  $> 10K$

### Partyline Input

**Crosstalk:**  $< -60$ dB  
**Max level before Clipping:**  $\geq 12$ dBu  
**Sidetone Null Capability:**  $> 25$ dB

### Stage Announce/Balanced Line Out

**Type:** Balanced  
**Output Impedance:**  $\geq 200$   
**Load Impedance:**  $\geq 600$

### IFB/Hot Mic

**Type:** Unbalanced  
**Output Impedance:** 180  
**Load Impedance:**  $\geq 600$

### Frequency Response

**Panel Mic - Partyline:** 600 - 10kHz  $\pm 3$ dB  
**Headset Mic - Partyline:** 200 - 12kHz  $\pm 3$ dB  
**Headset Mic - Line Out:** 200 - 12kHz  $\pm 3$ dB  
**Program Input - Partyline:** 100 - 17kHz  $\pm 3$ dB  
**Program Input - Headset Out:** 200 - 10kHz  $\pm 3$ dB  
**Program Input - Speaker Out:** 300 - 10kHz  $\pm 3$ dB  
**Partyline - Headset Out:** 200 - 10kHz  $\pm 3$ dB  
**Partyline - Speaker Out:** 300 - 10kHz  $\pm 3$ dB

### Max Distortion

**Panel Mic - Partyline:**  $\leq 0.5\%$   
**Headset Mic - Partyline:**  $\leq 0.5\%$   
**Headset Mic - Line Out:**  $\leq 0.5\%$   
**Program Input - Partyline:**  $\leq 0.2\%$   
**Program Input - Headset Out:**  $\leq 0.2\%$   
**Program Input - Speaker Out:**  $\leq 0.5\%$   
**Partyline - Headset Out:**  $\leq 0.2\%$   
**Partyline - Speaker Out:**  $\leq 0.5\%$

### Noise

**Panel Mic - Partyline:**  $< -65$ dBu  
**Headset Mic - Partyline:**  $< -70$ dBu  
**Headset Mic - Line Out:**  $< -55$ dBu  
**Program Input - Partyline:**  $< -85$ dBu  
**Program Input - Headset Out:**  $< -60$ dBu  
**Program Input - Speaker Out:**  $< -60$ dBu  
**Partyline - Headset Out:**  $< -50$ dBu  
**Partyline - Speaker Out:**  $< -50$ dBu

### Max Gain

**Panel Mic - Partyline:**  $\geq 37$ dB  
**Headset Mic - Partyline:** 41dB  $\pm 2$ dB  
**Headset Mic - Hot Mic Out:** 55dB  $\pm 3$ dB  
**Headset Mic - Announce Out:** 55dB  $\pm 3$ dB  
**Program Input - Partyline:**  $\geq -16$ dB  
**Program Input - Headset Out:**  $\geq 18$ dB  
**Program Input - Speaker Out:**  $\geq 24$ dB  
**Partyline - Headset Out:**  $\geq 34$ dB  
**Partyline - Speaker Out:**  $\geq 40$ dB

### Min Gain

**Panel Mic - Partyline:**  $\leq 25$ dB  
**Mains Power**  
**Input Voltage Range:** 100 - 240V AC  
**Input Frequency Range:** 50 - 60Hz  
**Input Power:**  $\leq 60$ V AC  
**Output Voltage:** 30V DC  $\pm 0.5$ V  
**Output Current per Channel (Continuous):** 1.2A  
**Output Current per Channel (Peak):** 2A (Do not exceed the 1.2A rating for more than 2 seconds per 1 minute period)  
**Short Circuit Recovery Time (1st short):**  $\leq 0.5$  sec  
**Short Circuit Recovery Time  $\geq 20$  shorts in 20sec:**  $\leq 20$  sec

### Environmental

32° - 122°F (0° - 50°C)

### Dimensions

1.75 x 1.9 x 6.5in (HxWxD)  
(44 x 483 x 165mm)

### Weight

6.1lbs (2.8kg)

# MS-702 Two-Channel Main Station

Analog Partyline Solutions

## MS-702 Front Panel

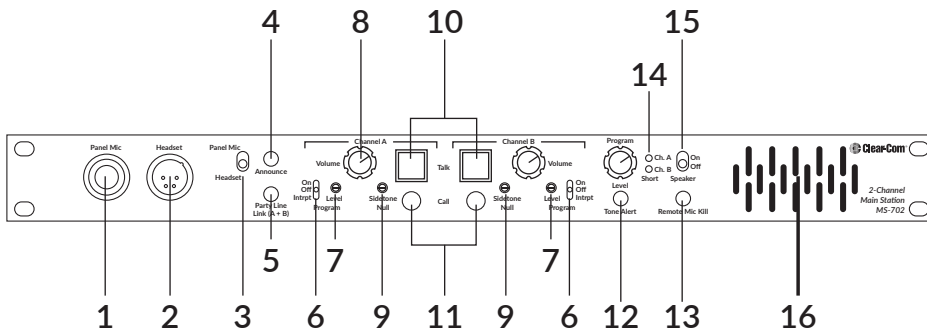

## MS-702 Back Panel

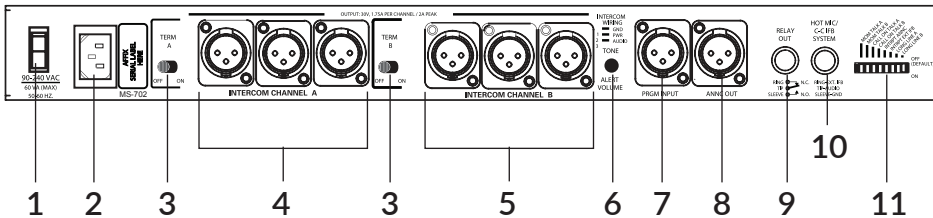

## Legend

### Front Panel

1. Microphone connector
2. XLR-4M Headset connector
3. Mic Select Switch
4. Announce button
5. Partyline Link button
6. Program ON/OFF/INTERRUPT switch
7. Program Level control
8. Volume control
9. Sidetone Null control
10. Talk button
11. Call button
12. Tone Alert button
13. Remote Mic Kill button
14. Short LED
15. Speaker ON/OFF switch
16. Speaker

### Back Panel

1. Power ON/OFF switch
2. Power connector
3. Termination ON/OFF switch
4. Channel A XLR-3M intercom connectors
5. Channel B XLR-3M intercom connectors
6. Tone Alert Volume control
7. Program Input
8. Announce Out
9. Relay Out
10. Hot Mic / IFB Interface
11. Dip switch options

## Order Code

MS-702



[www.clearcom.com/encore-knowledge-center/](http://www.clearcom.com/encore-knowledge-center/)