

tunwallradio.com
330-995-9642

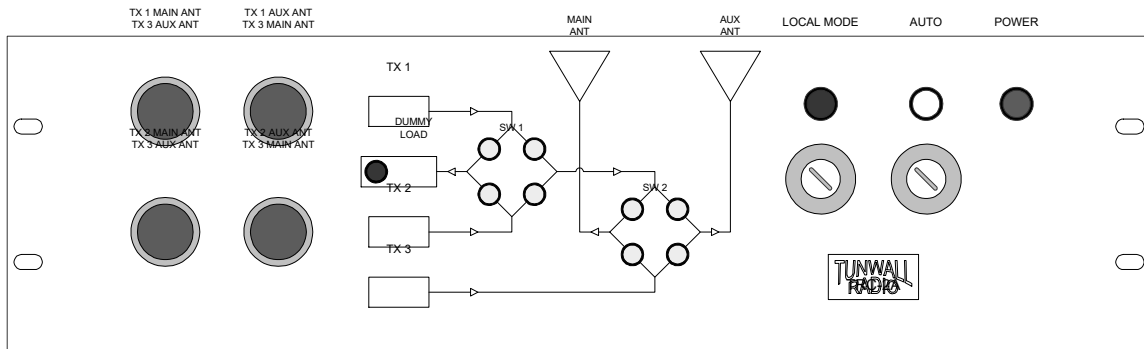

TRC-2A

INSTALLATION AND SERVICE MANUAL

Rev. March 2010



IF THE TX 2 MAIN OR AUX ANT INDICATOR IS FLASHING....

The controller has probably auto-transferred because TX 1 has failed. Turn off the AUTO key switch or select any pushbutton or remote command.

IF THE CONTROLLER WON'T MOVE THE COAXIAL SWITCHES....

It is probably related to the RF OFF terminals. If TB2-1 (common) is not connected to TB2-2 and TB2-3 by external equipment or terminal jumpers, the controller is programmed not to move the switches.

TRC- 2A – general	2
PLC (programmable logic controller)	2
CONNECTIONS	2
Coax switch connections	2
Command polarity	2
Remote control inputs	3
Remote control status outputs	3
Plate on and off connections	3
Transmitter and antenna logic	3
Motor control relays	4
Transmitter interlock connections	4
Dummy load connection	4
Auto transfer connections	5
Transmitter off tally connection	6
OPERATION	6
Transmitter interlocks	7
Plate on and off	7
Transmitter 1 and 2 plate off exceptions	7
Transmitter 3 plate off exceptions	8
Transmitter off tally	8
Front panel position indicators	8
Remote control commands	9
Local key switch	9
Auto transfer	9
Fuses	9
Controller schematic diagram	10
Interconnection chart	11
Coax switch connection chart	12
Logic tables	13
Component and board layout	14
Dielectric 50000 series switch manual	1-7
Dielectric 60000 series switch manual	1-10

TRC-2A DUAL SWITCH CONTROLLER

This is a controller for two coaxial switches, three transmitters, two antennas and a dummy load. It was designed for Dielectric 50000 and 60000 series coax switches but will also work with Delta, Andrew, MCI, and others. Coax switches are connected to 9-pin AMP connectors, with cables or plugs provided. All other connections are made to barrier strip terminals.

PLC (PROGRAMMABLE LOGIC CONTROLLER)

This is a PLC-based controller. All functions are controlled by a NAIS FP0 programmable logic controller and expansion modules. Programmable logic controllers are not well known to broadcast engineers but have been widely used in the manufacturing industry for decades. The FP0 is a microprocessor controller, built into a convenient package that includes the power supply, input isocouplers, output relays, status indicators, terminals and connectors, and a programming interface. PLC's are designed and constructed to survive and perform in the environments found in industrial facilities, which typically present several challenges to electronic equipment; heat, dust, vibration, magnetic fields, and power line transients. The FP0 is very reliable in general, and will hold its memory indefinitely with power removed.

No knowledge of PLC programming is needed to install and use the controller.

The PLC and expansion modules in this controller have opto-isolated electronic logic inputs, and relay contact outputs. The controller will work with any relay command inputs. Open collector equipment may be used if compatible with positive common wiring.

CONNECTIONS

COAX SWITCH CONNECTIONS

Coax switches connect to the 9-pin AMP connectors SW1 and SW2. Note that 120 VAC is available for the coax switch motors on pins 8 (hot) & 9 (neutral), for switches that are powered by the controller. The pins for the 9-pin AMP connectors are the same as in the larger AMP connectors on Dielectric 60000 coax switches. Many ratcheting crimpers used for audio console installation will work. The pins for the controller side were installed with a Paladin 1645, Newark part #97B3917. A coax switch connection terminal page is provided.

An overall wiring chart is provided for convenience of installation. There is also a coax switch connection terminal page.

COMMAND POLARITY

The header plug labeled "polarity" on the interconnect board is to reverse DC polarity for Andrew coax switches. Reversed polarity is only required for Andrew switches.

REMOTE CONTROL INPUTS

Controller terminals 1-6 to 1-10 are the remote position select connections. Floating relay contacts are best, such as the Burk IP-8, but open collector equipment may be compatible depending on its polarity.

REMOTE CONTROL STATUS OUTPUTS

Controller terminals 1-1 to 1-5 are remote position status outputs. These outputs are connected through diodes to the front panel pushbutton indicators. The PLC used in the controller was selected because of its low cost, and it has a limited number of outputs, so the indicators and the remote status outputs share PLC outputs. This status output circuit is compatible with all known remote control systems, Burk as an example. The Burk ARC-16 documentation states that its status inputs can be connected to circuits up to 28 VDC. The only requirement is that one state of the circuit be ground, or near enough to pull the DC close to ground potential. The PLC output relays cause the status output terminals to go near ground when a remote status indication is desired. The series diodes keep the controller's front panel indicators from lighting through the remote control's pull-up resistors

PLATE ON AND OFF CONNECTIONS

Plate on and off closures are available on TB3 and TB4, as shown on the interconnections page. These connections are optional, and their use is discussed further in the OPERATION section. The transmitters and coax switches will operate safely if only the transmitter interlock terminals are connected. You may want to connect only some of the plate on and off functions. Some solid state transmitters do not have a true interlock circuit; they will not come back on when the interlock closure is restored. The appropriate plate on closure may be able to correct this.

"Plate" is a traditional term; RF on and off may apply to solid state transmitters. For most tube transmitters, plate on will start the filament delay sequence and eventually turn the transmitter on. If desired, the plate off closures could be connected to the filament off inputs of some tube transmitters; if the filament time-out circuitry is working correctly, the plate will go off immediately, and the filament will go off later after the tube has had time to cool.

TRANSMITTER AND ANTENNA LOGIC

The controller needs to know which position the coax switches are in, to make the transmitter interlocks work correctly. Depending on the layout of the transmission lines, position 1 of either switch might be the reverse of the RF path shown on the controller front panel. The controller can easily reverse the indication and command logic of the coax switches with terminal jumpers on TB2.

If both switches are in position 1 when the controller is "normal" (TX1 on main antenna), neither jumper is needed. If TX1 is connected to the main antenna when switch 1 is in position 2, reverse switch 1 with a jumper from TB2-8 to TB2-9. If TX1 is connected to the main antenna when switch 2 is in position 2, reverse switch 2

with a jumper from TB2-8 to TB2-10. Both switches can be reversed with a 3-spade jumper connecting all 3 terminals.

MOTOR CONTROL RELAYS

The controller is compatible with coax switches that have 120 VAC, 12 or 24 VDC motor control relays. The 12V – 24V jumper plug on the controller's internal board selects these voltages. The DC – 120V jumper plug changes the command output wiring for DC or AC (see diagram). Only the 24VDC setting can be used with Andrew coax switches, and the polarity plug must be changed.

Solenoid-type switches may be compatible with the controller but they are generally considered inferior to motorized types, so no consideration for solenoid switches was given to the controller design.

The schematic diagram indicates the Dielectric 50000 switch terminal letters. Connections for other switches are on the coax switch connections page.

TRANSMITTER INTERLOCK CONNECTIONS

The controller's interlock terminals are to be connected to the interlock or mute terminals of the transmitter(s). Older transmitters may not have terminals designated for this purpose, but may have connections for remote plate off. If this circuit operates with a continuous closure that holds the plate on, the controller's interlock terminals may be wired in series with this circuit. The PLC's transmitter interlock outputs are floating relay contacts.

The controller's internal board includes jumper plugs to select transmitter 1 and 2 interlock logic. With the jumpers set to NO (normally open), the interlock terminals will work correctly for transmitters that require a closure to run. Most FM transmitters have close-to-run interlock circuits. With either jumper (TX 1 or TX 2) set to NC, the interlock terminals will work correctly for transmitters that require a closure to mute. Most AM and some newer FM transmitters have close-to-kill external interlock circuits. Interlock logic for transmitter 3 can be reversed by a jumper between TB2-6 and TB2-7.

The PLC relay contacts are rated for 250 VAC, 2A. It is up to the engineer's judgment whether to bring high voltage control circuits out of older transmitters. Since the barrier strip terminals on the controller are somewhat exposed, it might be best to install low voltage relays in transmitters with high voltage controls.

DUMMY LOAD CONNECTION

The tally terminals of your dummy load should be connected to controller terminals TB2-4 and TB2-5. The PLC has been programmed to operate correctly with a dummy load contact closure when the blower or water is "on". This allows an off-air transmitter to be energized, for testing on the load. When the load is off, the transmitter switched to it will be muted. Its filament and blowers should be able to operate.

If the station's load is a convection type, a switch for the load interlock terminals should be installed in the rack and labeled "LOAD INTERLOCK". This way the off-air transmitter will normally not be allowed to run when no one is at the transmitter site, but it is easy to use the switch to allow load testing.

A "load interlock" switch might also be desirable with Altronic loads, due to the nature of their tally contact operation – whenever power is applied, their tally contacts close. This could allow operator error to turn on an off-air transmitter, and while the load would theoretically not be damaged, the heat from the extra transmitter and the load could cause problems in many transmitter buildings, given some time. Or, you might decide to leave an Altronic load disconnected from power when no one is there.

The controller is able to switch positions when the load interlock is active, but the coax switch is still protected from "hot" switching – the transmitters will be muted.

AUTO TRANSFER CONNECTIONS

This is an optional function, selected by a front panel key switch, to transfer to TX 2 if TX 1 fails.

If you are going to use AUTO mode, you may not want to connect the controller to a UPS (not that this is required in any case). Auto mode will not do anything for 5 minutes after power-on, to avoid unwanted transfers due to power interruptions (the auto mode indicator is powered by the key switch, so it comes on immediately). A UPS would keep the 5 minute delay from resetting during power interruptions.

The controller's PLC "boots up" almost instantly when power comes on, and the controller will not output any commands during power on-off cycles.

Connections for auto transfer are made to TB3. In auto mode, to tell the controller that TX 1 is working, a TX 1 "on" signal must be provided:

A continuous closure from floating contacts, maintained when the transmitter is running, or

Continuous 5 volts DC when the transmitter is running. These terminals are not connected to ground in the controller.

The Transmitter 1 ON closure or 5 volt signal can come from the transmitter, an external RF detector, some VSWR monitors, a modulation monitor, or any other device. The controller does not have an RF detector; the sample available at one station could be hundreds of times the voltage at another station. A detector that could operate reliably at any RF voltage but not be damaged by overvoltage would be too complex and expensive to include as an option that will not be used by all stations.

The 5 volt option energizes a small single pole relay, whose NO contacts are connected in parallel with the controller's transmitter fail closure input. The current draw of the 5 volt relay is 72ma. The 5 volt relay coil has a "protection" diode, so

polarity matters, and is indicated on the schematic drawing and interconnection chart. If the transmitter 1 on closure opens, or if the 5 volt signal drops for more than 5 seconds, the controller will switch to transmitter 2, without changing antennas. If the closure or 5 volt signal drops for less than 5 seconds and resumes, the 5 second timer resets.

TRANSMITTER OFF TALLY CONNECTION

If desired, the controller can be connected to external circuits to prevent coax switches from moving unless RF is confirmed off. The controller's delay between a switching command (interlocks mute the transmitters) and the time the coax switches start to move is usually more than enough to prevent hot switching, so this is optional. If a transmitter outputs RF after it has been muted, its plate bleeder resistors may be open, and should be replaced.

Most transmitters do not have output circuits for this purpose, so transmitter modification or external equipment is usually needed. Closures to indicate RF off will be connected from TB2-1 (common) to TB2-2&3. If only one RF off signal is to be used, connect it to TB2-2 or TB-3, and connect a jumper to the other.

OPERATION

From a single command, the controller operates the transmitter interlocks and switch motors in a timed sequence such that the switches are never moved with RF power applied. The transmitters are "interlocked" or muted, before the switch motors are energized. The PLC in this controller has been programmed to wait 1 second after the interlock terminals open before the coax switches will begin to move.

The 4 large front panel pushbuttons are the local controls for:

TX 1 MAIN ANT/TX 3 AUX ANT
TX 1 AUX ANT/TX 3 MAIN ANT
TX 2 MAIN ANT/TX 3 AUX ANT
TX 2 AUX ANT/TX 3 MAIN ANT

Pushing any button locks out the other 3 for the duration of the switching sequence. The switching sequence is: transmitter interlock connections open, 1 second delay; coax switch operation (as long as it takes up to 30 seconds); at completion of switch movement, 0.2 second interlock delay, and transmitter interlock(s) on.

The controller has terminals for remote position change commands. These work exactly as the front panel pushbuttons unless the controller is in local. In local, only the front panel pushbuttons are active.

After a switch sequence has been started, if the coax switch "hangs", the transmitter interlock will not be completed. This is the primary purpose of the controller, of course; preventing the coax switches from being moved under power, or having power applied when they are not in position. If a switch hangs during a transfer and

is then manually moved to either position, the controller will enable the interlock(s) for the correct transmitter(s) for that combination of switch positions. The controller is programmed to reset itself after 30 seconds, if a coax switch hangs. After the 30 second time-out, you can try the position change again, or return to the previous position. If the front panel pushbutton for the position a coaxial switch is already in is pushed, nothing will happen.

If a coaxial switch is moved manually, the related transmitter interlocks will open. This doesn't make it safe or a good idea to move a switch manually under power. If a switch is moved manually, when it "makes" either position, there will be a 0.2 second delay before the transmitter interlocks are restored.

TRANSMITTER 1 AND 2 INTERLOCKS

Transmitter 1 or 2, whichever is on-air or if the other is running into the load, will be muted by interlock when any switch command is selected, for the duration of the switching sequence.

TRANSMITTER 3 INTERLOCK EXCEPTION

Switching between TX 1 and TX 2 without changing antennas will not cause the TX 3 interlock or its plate off closure to operate.

PLATE ON AND OFF

The term "plate" may become obsolete eventually, but most engineers will understand that it is equivalent to RF or power, or whatever terms newer transmitters may use.

No plate on or off connections are necessary. The coax switches will be fully protected if the interlock circuits are the only power controls connected.

The optional on/off connections are available on TB3 and TB4, as indicated on the interconnections page. Plate off closures are momentarily energized for 0.5 second at the start of any transmitter switch cycle, at the instant when interlocks open. Plate on closures are momentarily energized for 0.5 second at the end of a transfer sequence, at the same instant when interlocks are restored.

The plate on closures can help with some newer FM transmitters that will not come back on after their interlock circuits have been used to mute RF. This type of "interlock" function seems to be more of an "off" function than an interlock, but some transmitters work this way.

TRANSMITTER 1 AND 2 PLATE OFF EXCEPTIONS

Plate off commands for transmitters 1 and 2 every time any switch command is issued would not be convenient – if the same transmitter will be on at the end of the sequence, such as when changing from TX1 MAIN ANT to TX1 AUX ANT, a plate off

closure would turn the entire transmitter off, and cause the station to be off-air longer than needed. Since the transmitters will be muted by the interlock terminals for any switch command, the controller is programmed to omit the plate off closure for transmitters 1 and 2 when the antenna is being switched but not the transmitter.

Similarly, assume transmitter 2 is running on the main antenna (TX2 MAIN ANT). You might want to warm up transmitter 1 before selecting TX1 MAIN ANT. A transmitter 1 plate off closure during this sequence would defeat the purpose of the advance warmup – transmitter 1 would be turned off during the switch, and the warmup would start all over again. The controller is programmed to omit the plate off closure for transmitters 1 and 2, for the transmitter that is going on-air. In the above example, the transmitter 2 plate off closure would operate, since transmitter 2 is going off-air.

TRANSMITTER 3 PLATE OFF EXCEPTIONS

Due to the switch port assignments in a TRC-2A – compatible RF system, transmitter 3 is never going off-air, so a plate off closure is probably not needed. The closure is part of the hardware, since the same PLC and board are used in other controllers. In most cases it is probably best not to connect the transmitter 3 plate off terminals to the transmitter. The transmitter 3 plate off closure has been programmed to operate only when switch 2 moves, in case it can be used for other switching or monitoring purposes.

TRANSMITTER OFF TALLY

The controller will not move the coax switches without continuity between TB2-1 and TB2-2&3. If the jumpers on these terminals have been removed and replaced with transmitter off tally circuits, the controller will not move the coax switches without this confirmation of RF off. If a switching command is given and the transmitter off tally signal(s) are completed later but within the 30 second timeout, the coax switch(es) will move.

FRONT PANEL POSITION INDICATORS

The small indicators in the front panel flow chart graphic show RF connections between transmitters and loads.

The dummy load indicator is on when the load interlock closure is closed, showing that the transmitter connected to the dummy load is ready to run. The 4 pushbuttons for transmitter changes are illuminated. Each of the 4 pushbutton indicators correspond to a third condition in addition to their labels:

TX1 MAIN ANT/TX3 AUX ANT	=	TX2 ON LOAD
TX1 AUX ANT/TX3 MAIN ANT	=	TX2 ON LOAD
TX2 MAIN ANT/TX3 AUX ANT	=	TX1 ON LOAD
TX2 AUX ANT/TX3 MAIN ANT	=	TX1 ON LOAD

The additional conditions are shown by the flow chart graphic.

During a switching sequence, the pushbutton indicator for the selected command will flash. If a coax switch hangs between positions, the controller will reset itself after 30 seconds, and either position can be selected for a second attempt.

All front panel indicators are solid-state.

REMOTE CONTROL COMMANDS

Terminals for 4 remote control command inputs are provided that duplicate the functions of the 4 front panel position pushbutton switches, except when the local key switch is activated

LOCAL KEY SWITCH

The local key switch can be used to lock out remote control commands. The front panel pushbuttons work in local.

The LOCAL and AUTO switches use the same key, which can be removed from either switch in either position.

AUTO TRANSFER

This is a key switch selected option that is only active in TX 1 MAIN ANT or TX 1 AUX ANT. There is a rear panel indicator, TX 1 PLT ON, that can be checked to verify the "ON" signal before turning the AUTO key switch. Auto transfer is not active for 5 minutes after power-on, to help avoid unwanted transfers due to power interruptions (the auto mode indicator is powered by the key switch, so it comes on immediately). Auto mode is also inactive for 1 minute after switching to TX 1 MAIN ANT or TX 1 AUX ANT, to provide time to get it running before another transfer occurs.

Turn the AUTO key switch to the right to engage automatic transfer. The transmitter 1 "on" signal has been connected to the transmitter fail closure terminals, according to the AUTO TRANSFER CONNECTIONS section. If the transmitter 1 "on" signal fails for 5 seconds, the controller will switch to transmitter 2, without switching antennas. The pushbutton/status output that has been switched to will flash after an auto transfer until reset, by turning off the auto key switch or selecting any of the 4 commands, by local pushbutton or remote control. If the pushbutton or remote command that is flashing is used for this reset, the controller will not move either coax switch or interrupt any transmitter by interlock.

FUSES

The 1/2A DC fuse is on the output of the 24V power supply. The 6A AC fuse is in series with the "hot" lead for the entire controller, and the AC power for the coax switches. Most coax switch motors are rated 1A, inrush approximately 3A. Some coax switches are not powered by the controller. Larger or smaller fuses can be used, at your judgment, if you have problems.

TRC-2A

INPUT AND OUTPUT CONNECTIONS MARKED WITH LETTERS ARE TO DIELECTRIC 50000 SWITCH. OTHER SWITCHES MAY BE USED.

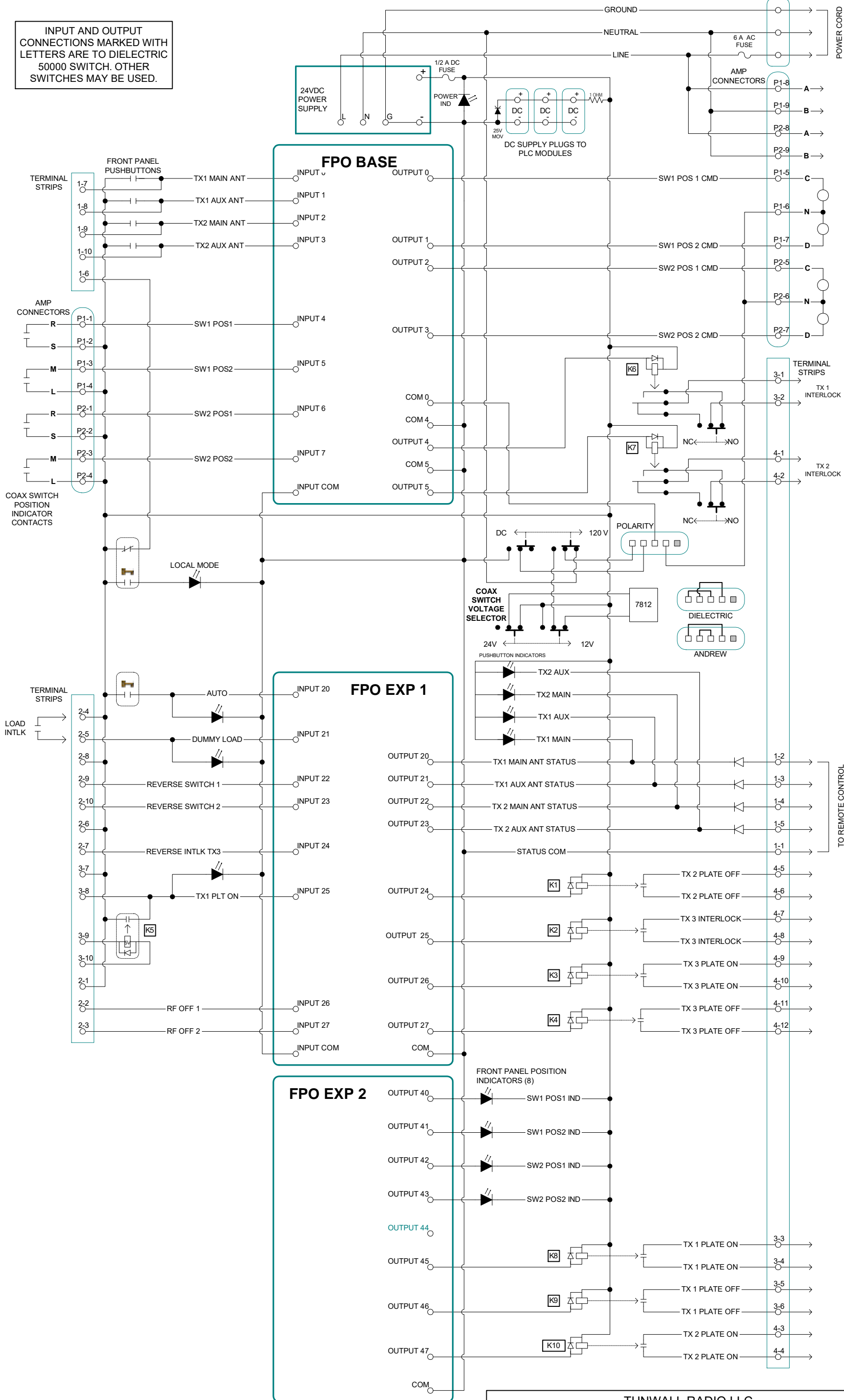

10

TUNWALL RADIO LLC			
DUAL COAXIAL SWITCH CONTROLLER			
	FPO BASE + 2 EXP	MARCH 2010	SHEET 1 OF 2
DRAWN BY		S. TUNWALL	

TRC-2A INTERCONNECTION CHART

**SW 1
SW 2**

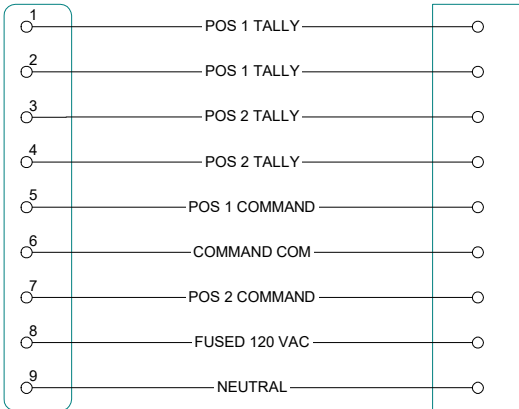

**COAX SWITCH 1
COAX SWITCH 2**

TB 3

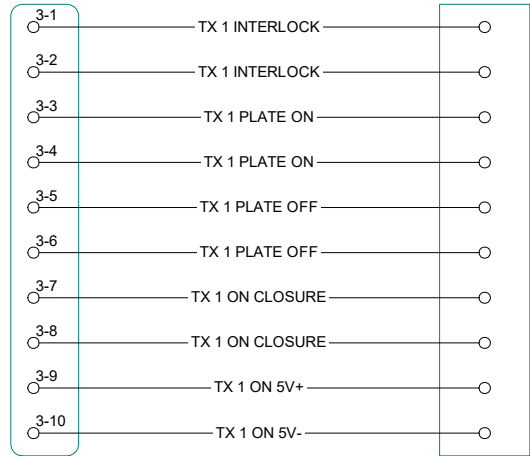

TRANSMITTER 1

TB 1

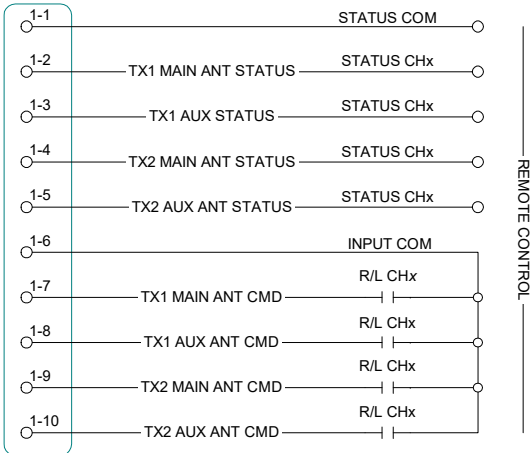

REMOTE CONTROL

TB 4

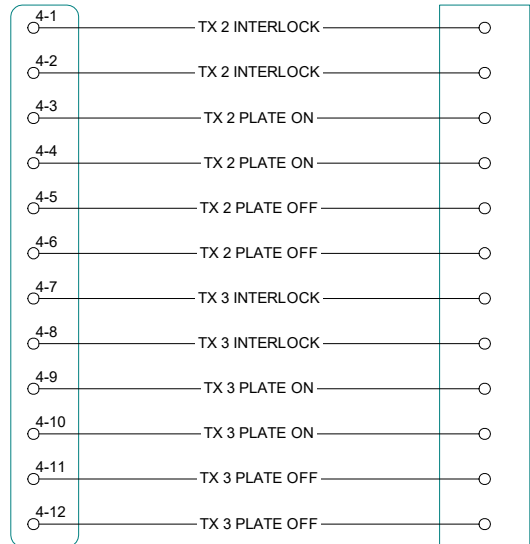

TRANSMITTER 2/3

TB 2

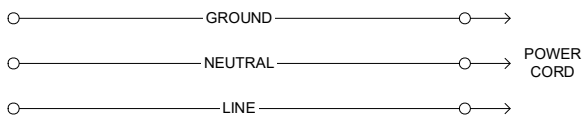
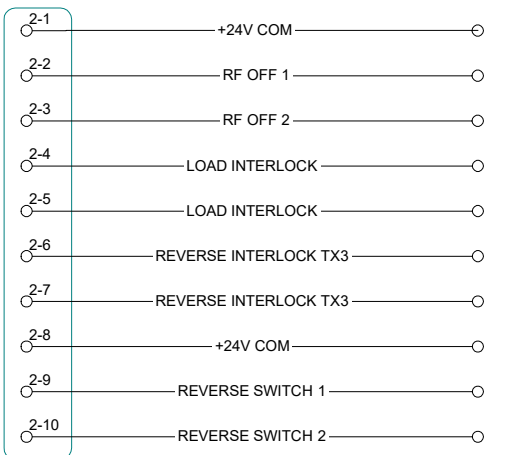

TUNWALL RADIO LLC			
DUAL COAXIAL SWITCH CONTROLLER			
FPO BASE + 2 EXP	MARCH 2010	SHEET 2 OF 2	
DRAWN BY		S. TUNWALL	

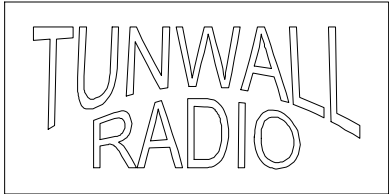

COAX SWITCH CONNECTIONS FOR FM CONTROLLERS

DIELECTRIC 50000 **DIELECTRIC 60000** **DIELECTRIC 50000** **DIELECTRIC 60000**
DC COMMANDS **DC COMMANDS** **AC COMMANDS** **AC COMMANDS**

DELTA

ANDREW

MCI

CONTROLLER Px

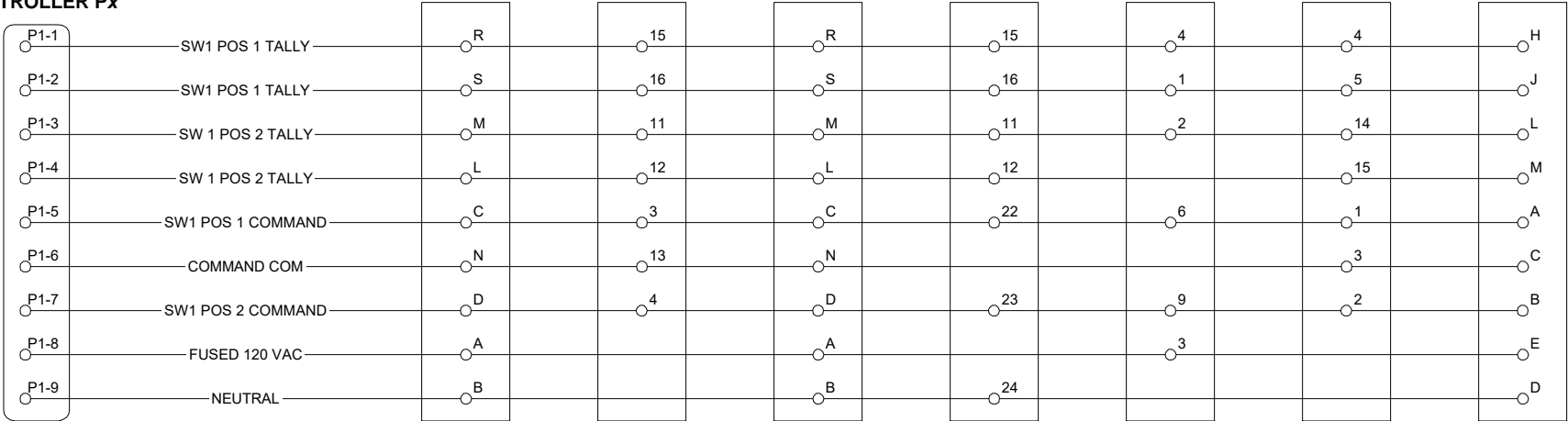

12

ANDREW REQUIRES REVERSE POLARITY HEADER

ANDREW 24VDC ONLY

DELTA 120VAC ONLY

MCI MAY HAVE 5V CONTROL RELAY - CHANGE TO 12V OR 24V

TERMINAL NUMBERS FOR DELTA, ANDREW, MCI MAY NOT BE CORRECT FOR EVERY MODEL

LOGIC TABLES TRC-2A

TRANSMITTER INTERLOCK LOGIC TABLES FOR ALL COMBINATIONS
OF COAX SWITCH REVERSE JUMPERS ON TB2

CAN ALSO BE USED AS COMMAND LOGIC TABLES

RUN = INTERLOCK TERMINALS
CLOSED, TRANSMITTER
ENABLED

MUTE L = MUTE, BUT
TRANSMITTER ENABLED WHEN
LOAD IS ON

SYSTEM COMMANDS	SWITCHES		TX 1	TX 2	TX 3
TX 1 MAIN ANT TX 3 AUX ANT	SW1 POS1	SW2 POS1	RUN	MUTE L	RUN
TX 1 AUX ANT TX 3 MAIN ANT	SW1 POS1	SW2 POS2	RUN	MUTE L	RUN
TX 2 MAIN ANT TX 3 AUX ANT	SW1 POS2	SW2 POS1	MUTE L	RUN	RUN
TX 2 AUX ANT TX 3 MAIN ANT	SW1 POS2	SW2 POS2	MUTE L	RUN	RUN

REVERSE SW 1

SYSTEM COMMANDS	SWITCHES		TX 1	TX 2	TX 3
TX 1 MAIN ANT TX 3 AUX ANT	SW1 POS2	SW2 POS1	RUN	MUTE L	RUN
TX 1 AUX ANT TX 3 MAIN ANT	SW1 POS2	SW2 POS2	RUN	MUTE L	RUN
TX 2 MAIN ANT TX 3 AUX ANT	SW1 POS1	SW2 POS1	MUTE L	RUN	RUN
TX 2 AUX ANT TX 3 MAIN ANT	SW1 POS1	SW2 POS2	MUTE L	RUN	RUN

REVERSE SW 2

SYSTEM COMMANDS	SWITCHES		TX 1	TX 2	TX 3
TX 1 MAIN ANT TX 3 AUX ANT	SW1 POS1	SW2 POS2	RUN	MUTE L	RUN
TX 1 AUX ANT TX 3 MAIN ANT	SW1 POS1	SW2 POS1	RUN	MUTE L	RUN
TX 2 MAIN ANT TX 3 AUX ANT	SW1 POS2	SW2 POS2	MUTE L	RUN	RUN
TX 2 AUX ANT TX 3 MAIN ANT	SW1 POS2	SW2 POS1	MUTE L	RUN	RUN

REVERSE SW 1
REVERSE SW 2

SYSTEM COMMANDS	SWITCHES		TX 1	TX 2	TX 3
TX 1 MAIN ANT TX 3 AUX ANT	SW1 POS2	SW2 POS2	RUN	MUTE L	RUN
TX 1 AUX ANT TX 3 MAIN ANT	SW1 POS2	SW2 POS1	RUN	MUTE L	RUN
TX 2 MAIN ANT TX 3 AUX ANT	SW1 POS1	SW2 POS2	MUTE L	RUN	RUN
TX 2 AUX ANT TX 3 MAIN ANT	SW1 POS1	SW2 POS1	MUTE L	RUN	RUN

TUNWALL RADIO LLC

DUAL FM SWITCH CONTROLLER

TRC-2A LOGIC TABLES

MARCH 2010

SHEET 1 OF 1

DRAWN BY

S. TUNWALL

TRC-2A COMPONENT LAYOUT

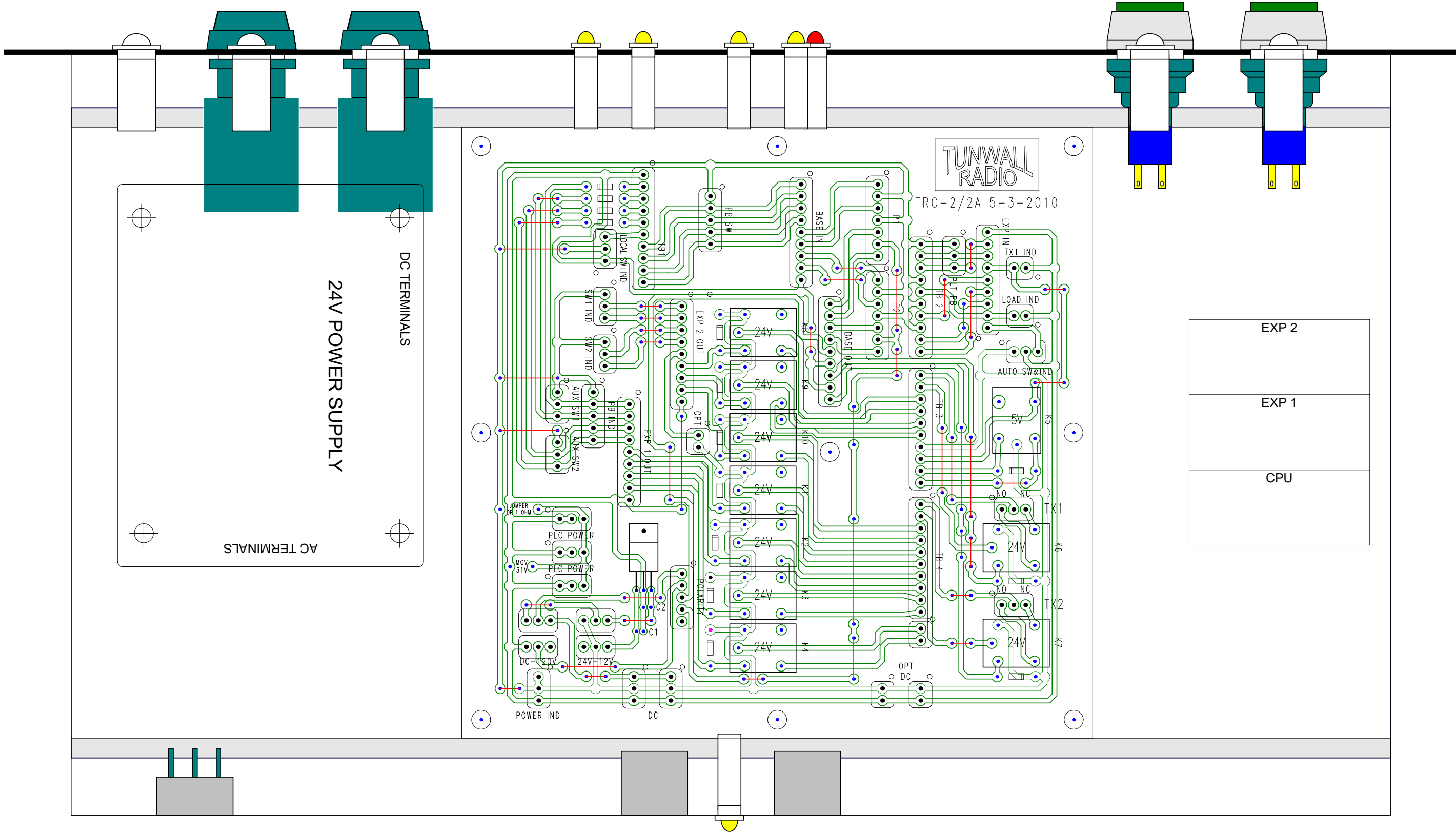

Instruction Manual

IB 016

DIELECTRIC

MODEL 50000

MOTORIZED

COAXIAL SWITCHES

1 $\frac{5}{8}$ & 3 $\frac{1}{8}$

DIELECTRIC COMMUNICATIONS

RAYMOND, MAINE, 04071 ■ TEL 207-655-4555 ■ TWX 710-229-6890

TABLE OF CONTENTS

Section	Title	Page
1.	General Description	2
2.	Specifications	2
3.	Theory of Operation	3
4.	Installation	3
5.	Operation	5
6.	Maintenance and Repair	5
7.	Replacement Parts	6
8.	Ancillary Equipment	6

LIST OF ILLUSTRATIONS

Figure No.	Title	Page
1.	Model 50000 3-1/8 4 Port Transfer Switch .. Inside front cover	
2.	Outline Drawing, Model 50000 1-5/8 and 3-1/8 Coaxial Switch	4
3.	Schematic Diagram, Model 50000 Coaxial Switch	7

Model 50000
Motorized Coaxial Switch

1. GENERAL DESCRIPTION.

The Model 50000 Coaxial Switch provides reliable and fast switching of coaxial transmission line systems. It is a motor driven, rotary type, and can be controlled locally and/or remotely.

The switch is equipped with a manual over-ride, a mechanical position indicator, and is fully protected with auxiliary read-out and inter-lock circuits.

Operable in any position and having a minimum of moving parts, 100,000 cycles are normal without failure.

EIA male flanges are standard with adapters available to mate with unflanged or semiflex transmission lines.

2. SPECIFICATIONS.

Size	1 5/8	3 1/8
Frequency Range	DC - 900 MHz	DC - 900 MHz
Characteristic Impedance	50 ohm	50 ohm
VSWR Maximum	1:05.1	1.05:1
Insertion Loss	0.1 db	0.1 db
Power Rating Peak Average @ 30 MHz @ 300 MHz @ 900 MHz	150 kw 25 kw 6 kw 4 kw	500 kw 90 kw 30 kw 15 kw
Switching Time, nominal	2 seconds	2 seconds
Isolation	60 db	60 db
R.F. Connectors	EIA Male	EIA Male
Drive Motor Current 1ø - 50/60 Hz @ 115V AC @ 230V AC	3.5 Amp., start; 0.5 Amp., run 1.5 Amp., start; 0.3 Amp., run	
Control Relay Power D.C. Coils A.C. Coils	1.2 Watts 2.7 Volt Amps.	
Auxiliary Switch Ratings @ 125V DC @ 250V AC	0.3 Amp. 10.0 Amps	
Net Weight	42 lb. - 19 kg.	54 lb. - 24.5 kg.
Gross Packed Weight	48 lb. - 21.7 kg.	65 lb. - 29.5 kg.
Gross Packed Cube	3.58 ft. ³ - .10 m ³	3.58 ft. ³ - .10 m ³

3. THEORY OF OPERATION.

The Model 50000 Coaxial Switch is a rotary type switch having an aluminum R.F. cavity common to all ports. The rotor assembly contains two inner conductor blades and a common isolating ground plane which oscillates 90° to accomplish the switching function and provide isolation between transmission line paths.

The rotor is driven by a gear motor and slip clutch mechanism. When the motor is activated by connection through the control relay, it will rotate 90° until the mechanism reaches a positive stop. Simultaneously an auxiliary switch is activated to interrupt the motor circuit. Any inertia of the drive is absorbed by slippage of the clutch mechanism.

Auxiliary switches are positioned at each end of travel and are adjusted so that in the closing mode they do not activate until the R.F. contacts are ready to accept power. Conversely, in the opening mode, the auxiliary contacts open prior to the R.F. contact to prevent the breaking of the switch under R.F. power.

4. INSTALLATION.

The switch may be mounted in any convenient position using the four (4) mounting holes shown in Figure 2. Orient the R.F. ports to meet the required transmission line layout.

The manual operate handle should be in an accessible location for emergency switching in the event of control power failure.

Provide twelve (12) inches clearance above the top of the motor drive cover to allow for removal for maintenance.

After the switch is properly mounted in position, remove hardware and protective covers from the R.F. connectors. Attach adapters or EIA female flanged lines to the switch ports and re-install hardware. CAUTION -- Tighten bolts evenly and do not exceed torque ratings of eleven (11) foot pounds on the 1-5/8 and twenty (20) foot pounds on the 3-1/8.

NOTE: The R.F. contacts of the switch flanges protrude above the flange surface, and when properly connected there will be a space between the flanges at the bolt circle. Tightening beyond rated torque will destroy both the switch flange and the mating transmission line flange.

Activate the R.F. switch manually to both positions to be sure rotor moves freely and reaches the positive stops.

Attach electrical supply wiring and control wiring to the removable MS3108B jack supplied with each switch. Refer to Figure 3 for proper connections.

Attach jack to plug and check readout and interlock circuits with continuity tester or ohm meter for proper operation.

Apply correct supply voltage.

Place R.F. switch rotor mechanism in approximately mid-position using manual operate knob.

Momentarily apply correct voltage to pins C and N (observe polarity) and check that position indicator starts to move toward position one. If rotation is incorrect check wiring; if correct, apply control voltage continuously to pins C and N.

Model 50000
 Motorized Coaxial Switch

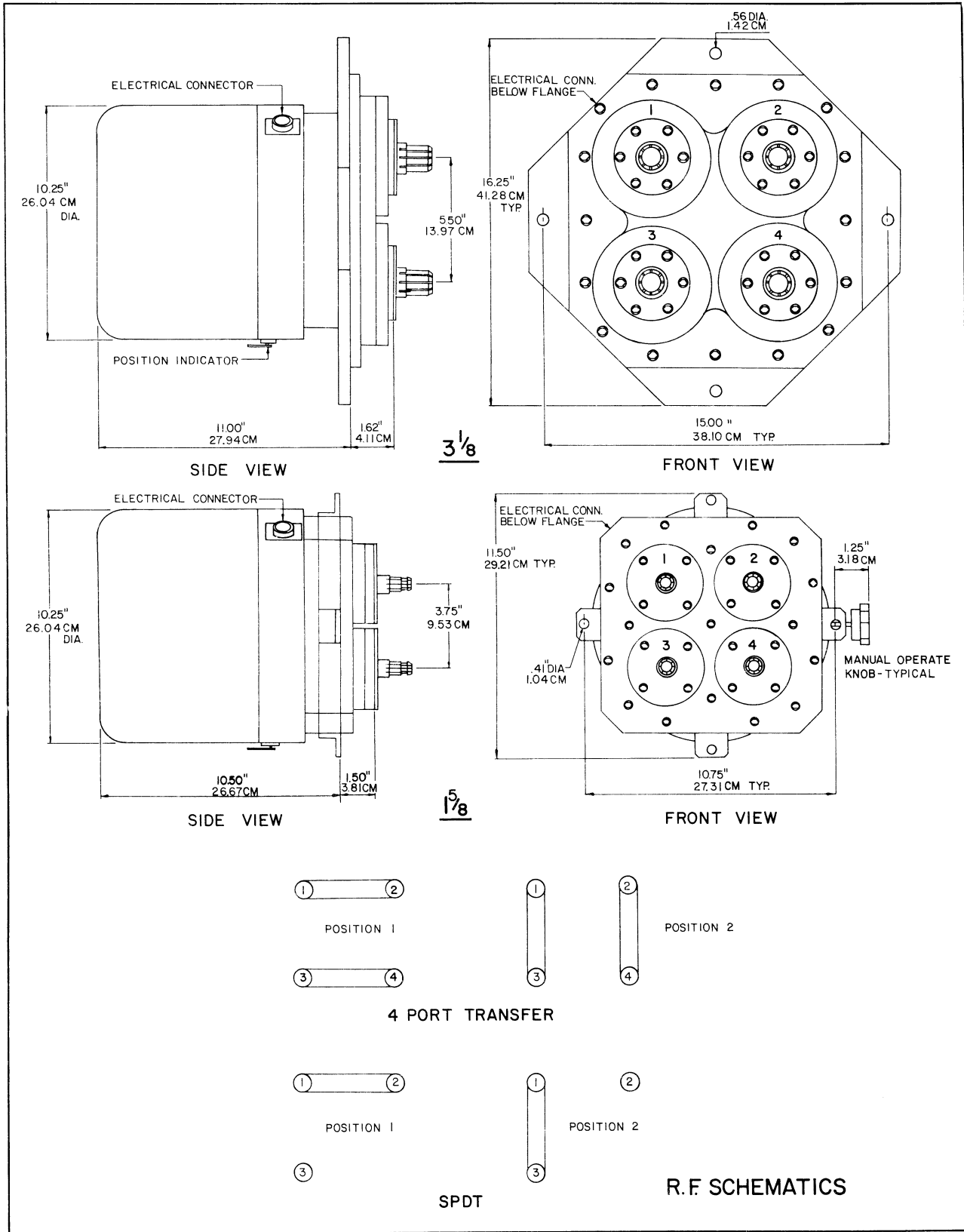
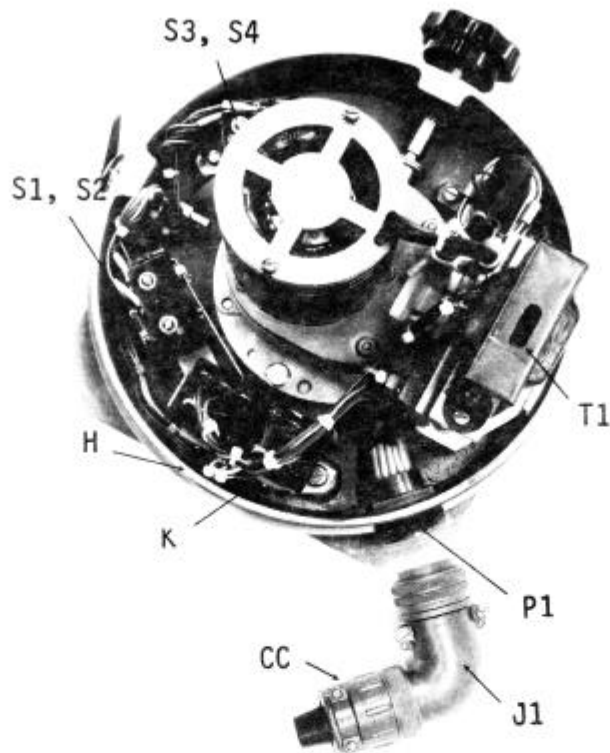

Figure 2. Outline Drawing Model 50000 1-5/8 and 3-1/8 Coaxial Switch

Model 50000
 Motorized Coaxial Switch



7. REPLACEMENT PARTS.

T1	Transformer, 220V-110V	A19636-1
S1, S2, S3, S4	Auxiliary Switch	A44876-1
K	Relay Assembly - 240V AC	B44624-501
	120V AC	B44624-502
	110V DC	B44624-503
	24V DC	B44624-504
	12V DC	B44624-505
P1	Plug	A44867-1
J1	Jack	A23561-1
CC	Cable Clamp	A19720-1
H	Harness Assembly (includes S1, S2, S3, S4, P1 and Relay sockets)	A44586-501

8. ANCILLARY EQUIPMENT.*

Adapter	3-1/8 EIA-F to 3-1/8 No Flange, 6" long	B44900-502
Adapter	3-1/8 EIA-F to 3-1/8 EIA-F, 6" long	C7999-501
Transition	3-1/8 EIA-F to 1-5/8 EIA-F, 6" long	B25623-501
Transition	3-1/8 EIA-M to Type N-F	C14397-503
Adapter	1-5/8 EIA-F to 1-5/8 No Flange, 6" long	B44920-502
Adapter	1-5/8 EIA-F to 1-5/8 EIA-F, 6" long	D30997-1
Transition	1-5/8 EIA-M to Type N-F	C21109-503

* All components listed are copper; similar items having aluminum outer conductors are available. Contact Dielectric Communications for a complete line of coaxial and waveguide transmission lines and components.

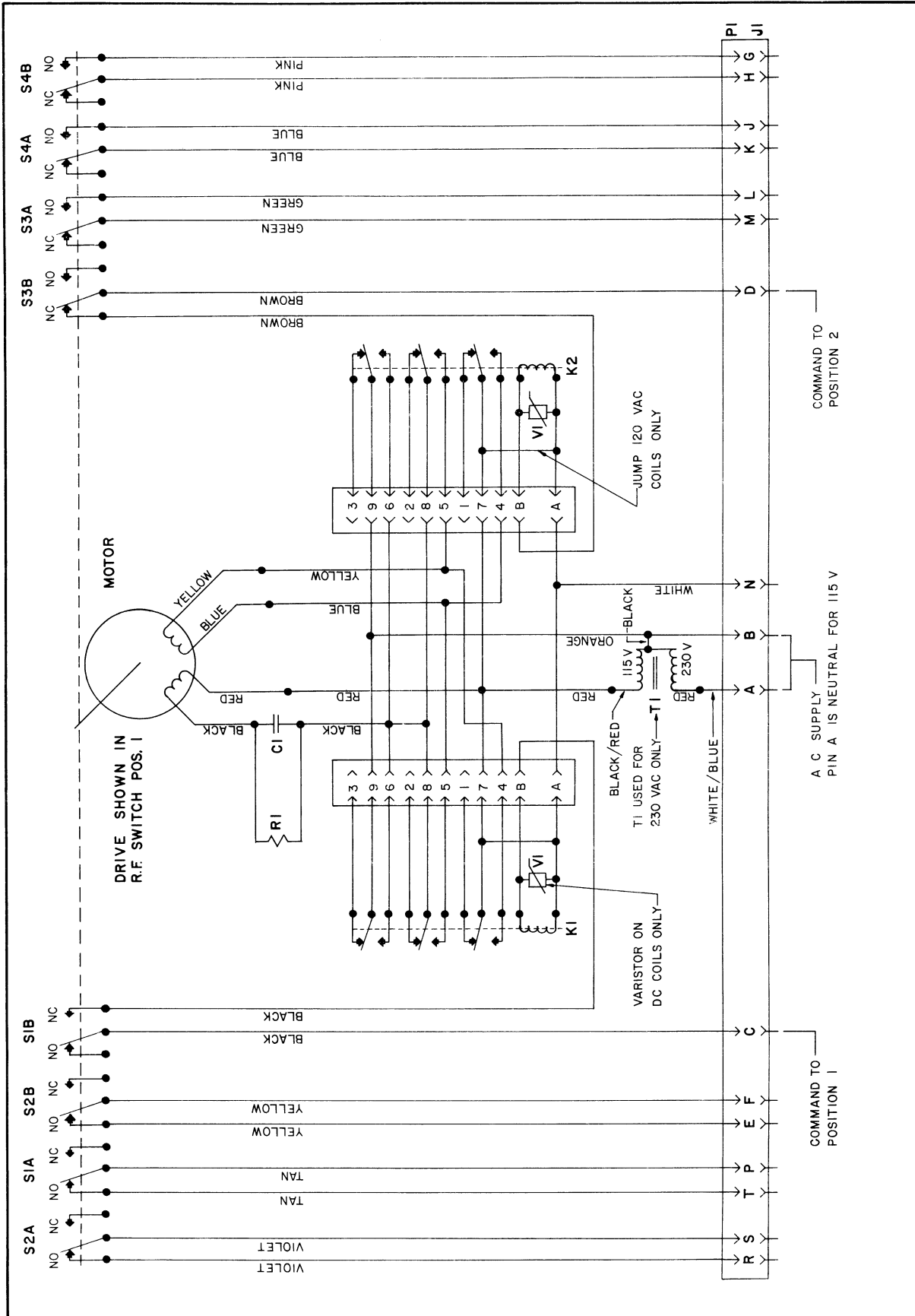

Figure 3. Schematic Diagram Model 50000 Coaxial Switch



IB-426-Rev D
P/N 85171

Model 60000
Motorized Coaxial Switches
1 5/8", 3 1/8", 4 1/16" and 6 1/8"

Instruction Manual

2/10/03

Table of Contents

1.0	General Description	2
2.0	Specifications	3
3.0	Theory of Operation	3
4.0	Installation	3
5.0	Operation	3-4
6.0	Maintenance and Repairs	4
7.0	Ancillary Equipment	5
Fig. 1	Outline Drawing	6
Fig.2	Wiring Diagram	7
	Wiring Table	8
	Wiring Details	9

Note: All specifications are for reference only. Consult factory for details.

WARNING

All Electrical and RF work must be done in accordance with local and national codes and safety requirements.

1.0 General Description

The Model 60000 Coaxial Switch provides reliable and fast switching of coaxial transmission line systems. It is a motor driven rotary type and can be controlled locally or remotely.

Operable in any position and having a minimum of moving parts, the switch will routinely operate through 1,000,000 cycles without failure.

The switch is equipped with a manual over-ride, mechanical position indicators and with auxiliary read-out circuits.

EIA male flanges are standard with adaptors available to mate with unflanged or semiflex transmission lines.

2.0 Specifications

	1 5/8"	3 1/8"	4 1/16"	6 1/8" 50 Ohm	6 1-8" 75 Ohm
Frequency Range	DC-900 MHz	DC-900 MHz	DC-800 MHz	DC-800 MHz	DC-800 MHz
Characteristic Impedance	50 Ohm	50 Ohm	50 Ohm	50 Ohm	75 Ohm
VSWR Max.	1.05:1				
Insertion Loss	0.1 dB max.				
Power Rating	150 kw	500 kw	1000 kw	2000 kw	1500 kw
Peak	25 kw	90 kw	150 kw	300 kw	225 kw
Average at 30 MHz	6 kw	30 kw	50 kw	100 kw	75 kw
Average at 300 MHz	4 kw	15 kw	25 kw	45 kw	38 kw
Average at 900 MHz					
Switching Time (nominal)	3 seconds	3 seconds	3 seconds	4 seconds	4 seconds
Isolation	60 dB				
RF Connectors	EIA Male				
Drive Motor Current 1Ø -50/60 Hz at 115 V AC at 230 V AC	Run Current 115 Nom. .6 AMP 230 Nom. .5 AMP			Start 115 Nom. 1.25 AMP 230 Nom. .9 AMP	
Auxiliary Switch Ratings	120 VAC 3A				
	28 VDC 3A				
Net Weight	36 lbs 16 kg	47 lbs 21.5 kg	60 lbs 27 kg	130 lbs 59 kg	120 lbs 54 kg
Gross Packed Weight	48 lbs 21.7 kg	65 lbs 29.5 kg	85 lbs 38 kg	185 lbs 84 kg	170 lbs 77 kg
Gross Packed Cube	3.58 ft ³ .10 m ³	3.58 ft ³ .10 m ³	9 ft ³ .26 m ³	12.6 ft ³ .35 m ³	12.6 ft ³ .35 m ³

3.0 Theory of Operation

The Model 60000 Coaxial Switch is a rotary type switch having an aluminum RF cavity common to all ports. The rotor assembly contains two inner conductor blades and a common isolating ground plane which oscillates 90° to accomplish the switching function and provide isolation between transmission line paths.

The rotor is driven by a gear motor. When the motor is activated by connection through the control, it will rotate 90°.

Six normally open microswitches are provided for position confirmation. The rotor activates these microswitches; and they must not be used for transmitter interlocking. **One must ensure that RF power is off before a position command is activated. Dielectric cannot be responsible for failure or burnout of switches switched under power.**

3.1 Inside the Drive

The drive used on the 60000 switches is an AC power segregated AC/DC command actuator. The drive is operated by 115 VAC, OR 230 vac and controlled by 12-24 VDC or 115/230 VAC. The different voltages can be selected without removing the cover. See the schematic for pin out for the configuration required. Do not apply AC and DC commands to the drive at the same time.

There is no need to open the switch unless local push button operation is required.

4.0 Installation

1. The switch may be mounted in any convenient position using the four mounting holes shown in Figure 1. Orient the RF ports to meet the required transmission line layout.

2. The manual operate handle stub should be in an accessible location for manual switching in the event of control power failure. Provide a minimum of eight inches of clearance above the top of the motor drive cover to allow for removal.

3. After the switch is properly mounted in position, remove hardware and protective covers from the RF connectors.

4. Attach adaptors or EIA female flanged lines to the switch ports and re-install hardware.

5. Note: The RF contact of the switch flanges protrudes above the flange surface and when properly connected there will be a space between the flanges at the bolt circle. Tightening beyond rated torque will destroy both the switch flange and the mating transmission line flange.

CAUTION

Tighten bolts evenly and do not exceed torque rating of eleven (11) foot pounds on the 1 5/8" switch or twenty (20) foot pounds on the 3 1/8", 4 1/16" and 6 1/8" switches.

5.0 Operation

The 1 5/8", 3 1/8", 4 1/16" AND 6-1/8" Model 60000 switches will change positions in approximately three seconds upon command.

The interlock circuits should be employed to prevent RF power being applied unless a legitimate RF transmission line path has been completed through the switch to an antenna or dummy load. Ensure that RF is off before the switch is commanded for position change.

Warning! User must remove all RF power before switching!

The 60000 series can be operated in four ways.

1. Locally with the cover removed.
2. Locally with the S60 Pendant. This device does not include any provisions for interlocks.
3. Remotely with connection through the Amp connector.
4. Manually with a 3/8" wrench or optional hand wheel.

To operate the switch locally with cover removed:

- A. Remove AC power and remove the cover.
- B. Set the "Man Run" switch to "Man". Plug in AC power
- C. Press either the "CW or CCW" button to desired position and hold until the motor stops.
- D. Reset "Man Run" switch to "Run" and replace cover when done.

To operate with the S60 Pendant:

- A. Connect Amp connector and AC power.
- B. The active side pilot light will illuminate.
- C. Select the desired position. Indicator lights will change status as switch moves.

To operate through Amp connector:

- A. Connect Amp connector and apply AC power.
- B. Connect control end cable and operate through control.

To operate manually:

- A. Assure AC power and Amp connectors are unplugged.
- B. Using wrench or hand wheel press down and turn until pointer on cover lines up with desired position.

6.0 Maintenance and Repairs

The Model 60000 Switch requires no periodic maintenance. However, after the initial installation is complete, the cover should be removed and the switch inspected for loose electrical connections and/or auxiliary switch hardware.

WARNING

Removal of the cover may expose live electrical terminals (240V AC maximum).

Some sub-assemblies of the units are sealed at the factory after test; breaking these seals voids any warranty and field repair of these assemblies is not recommended.

7.0 Ancillary Equipment*

	Description	Part Number
Adaptors		
1 5/8" EIA-F	to 1 5/8" no flange, 6" large	B-44920-502
	to 1 5/8" EIA-F, 6" large	D-30997-001
3 1/8" EIA-F	to 3 1/8" no flange, 6" large	B-44900-502
	to 3 1/8" EIA-F, 6" large	C-7999-501
4 1/16" EIA-F		
Transitions		
1 5/8" EIA-M	to Type N-F	C-21109-503
3 1/8" EIA-F	to 1 5/8" EIA-F, 6" large	B-25623-501
3 1/8" EIA-M	to Type N-F	C-14397-503
4 1/16" EIA-F		
Cable		
	Dual Switch Controller to 60000 Switch-25'	0101873-025
	Dual Switch Controller to 60000 Switch-50'	0101873-050
	To adapt 60000 switch CPC 24 pin to 16 pin AMP CPC ("Type C")	85156
	To adapt 60000 switch to 50000 amphenol connector	85144
S60 Pendant Control	10' AMP connector cable, AC power cable, and switch box.	85145
Extension Cable	25' Eight conductor cable assembly for longer S60 pendant applications.	85157

*All components are copper; similar items having aluminum outer conductors are available. Contact Dielectric Communications for a complete line of coaxial and waveguide transmission lines and components.

NOTE: PORT LOCATIONS
TYPICAL ALL SWITCHES

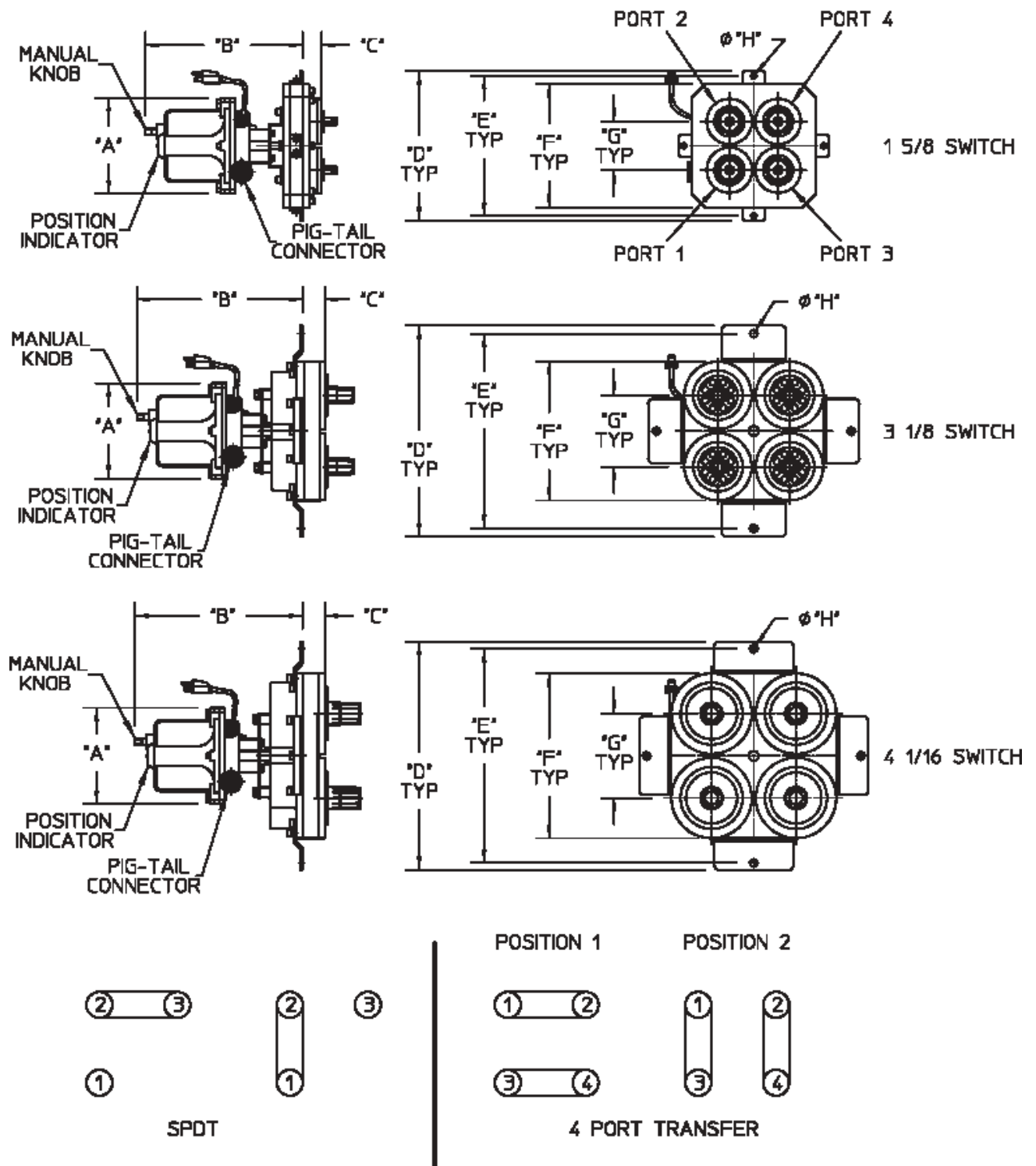

SWITCH	'A'	'B'	'C'	'D'	'E'	'F'	'G'	'H'
1-5/8	7.38	12.13	1.50	11.50	10.75	9.50	3.75	.41
3-1/8	7.38	12.75	1.74	16.25	15.00	10.69	5.50	.56
4-1/16	7.38	12.88	1.72	17.56	16.50	12.69	6.50	.56

Figure 1

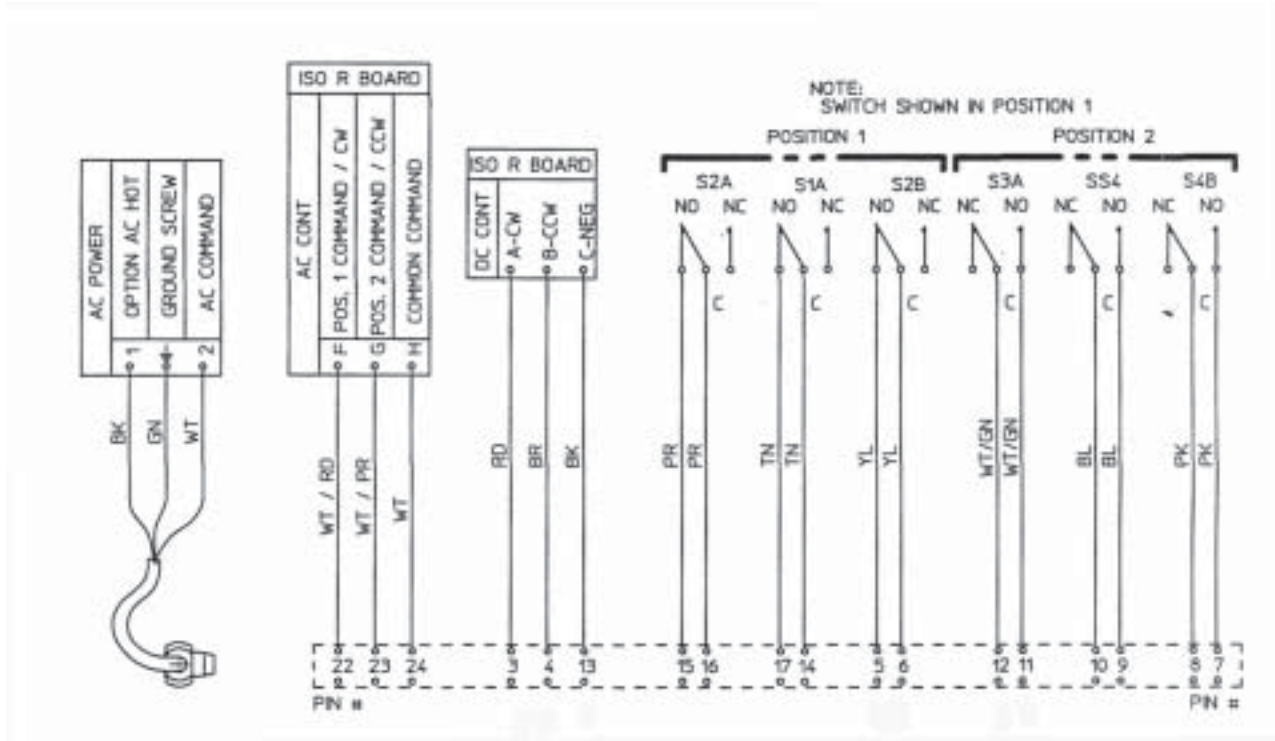

Figure 2

Note:

1. The actuator only requires a 1/2 second command pulse to latch the control in. A maintained command will not harm the unit.
2. Do not apply AC and DC commands at the same time.
3. For AC command between 110 VAC and 230 VAC, hook the common AC conductor to Pin 13 and position 1 and 2 commands to pins 22 and 23.
4. For DC command between 12 and 24 VDC, hook the negative conductor to pin 13 and the position 1 and position 2 to pins 3 and 4.

The actuator has been tested to operate at 10% less than the rated input voltage and is dual rated for 50/60 Hz operation.

WIRING TABLE

50000 PIN #	50000 SWITCH	50000 COLOR	DUAL SWITCH CONTROLLER	WAVEGUIDE SW	UNIVERSAL CONTROL PANEL	60000 PIN #	60000 SWITCH	60000 COLOR
	COMMENT		66982	DC Com AC Mot PIN #	48112-501		COMMENT	
					TB-4 Terminal #			
R	POS # 1 CONTACT S2A NO	VIO	15	J	15	15	POS # 1 CONTACT S2A NO	PR
S	POS # 1 CONTACT S2A COM	VIO	16	S	16	16	POS # 1 CONTACT S2A COM	PR
T	POS # 1 CONTACT S1A NO	TAN	17	F	17	17	POS # 1 CONTACT S1A NO	TN
P	POS # 1 CONTACT S1A COM	TAN	14	G	14	14	POS # 1 CONTACT S1A COM	TN
E	POS # 1 CONTACT S2B NO	YEL	5	Q	5	5	POS # 1 CONTACT S2B NO	YL
F	POS # 1 CONTACT S2B COM	YEL	6	P	6	6	POS # 1 CONTACT S2B COM	YL
C	COMMAND FOR POS #1	W/BLK	3	U	3	3	DC COMMAND FOR POS #1 (+)	RD
A	AC POWER	W/BLK	1	N/A	Used on 50, not on 60	N/A	N/A	N/A
B	AC POWER	WHT	2	N/A	Used on 50, not on 60	N/A	N/A	N/A
N	COMMAND COMMON	ORG	13	R	13	13	DC COMMAND COMMON (-)	BK
D	COMMAND FOR POS # 2	BRN	4	V	4	4	DC COMMAND FOR POS # 2 (+)	BR
M	POS # 2 CONTACT S3A COM	W/GRN	12	B	12	12	POS # 2 CONTACT S3A COM	WT/GRN
L	POS # 2 CONTACT S3A NO	W/GRN	11	A	11	11	POS # 2 CONTACT S3A NO	WT/GRN
K	POS # 2 CONTACT S4A COM	BLU	10	L	10	10	POS # 2 CONTACT S4A COM	BL
J	POS # 2 CONTACT S4A NO	BLU	9	M	9	9	POS # 2 CONTACT S4A NO	BL
H	POS # 2 CONTACT S4B COM	PNK	8	D	8	8	POS # 2 CONTACT S4B COM	PK
G	POS # 2 CONTACT S4B NO	PNK	7	E	7	7	POS # 2 CONTACT S4B NO	PK
						1	RESERVED FOR HEATER	
						2	RESERVED FOR HEATER	
						18	N/A	N/A
						19	N/A	N/A
						20	N/A	N/A
						21	N/A	N/A
						22	AC COMMAND POS # 1	WT/RD
						23	AC COMMAND POS # 2	WT/PR
						24	AC COMMAND COMMON	WT

Wiring Details

