

F-10A

FIELD Production Monitor

Operation manual_V2.0

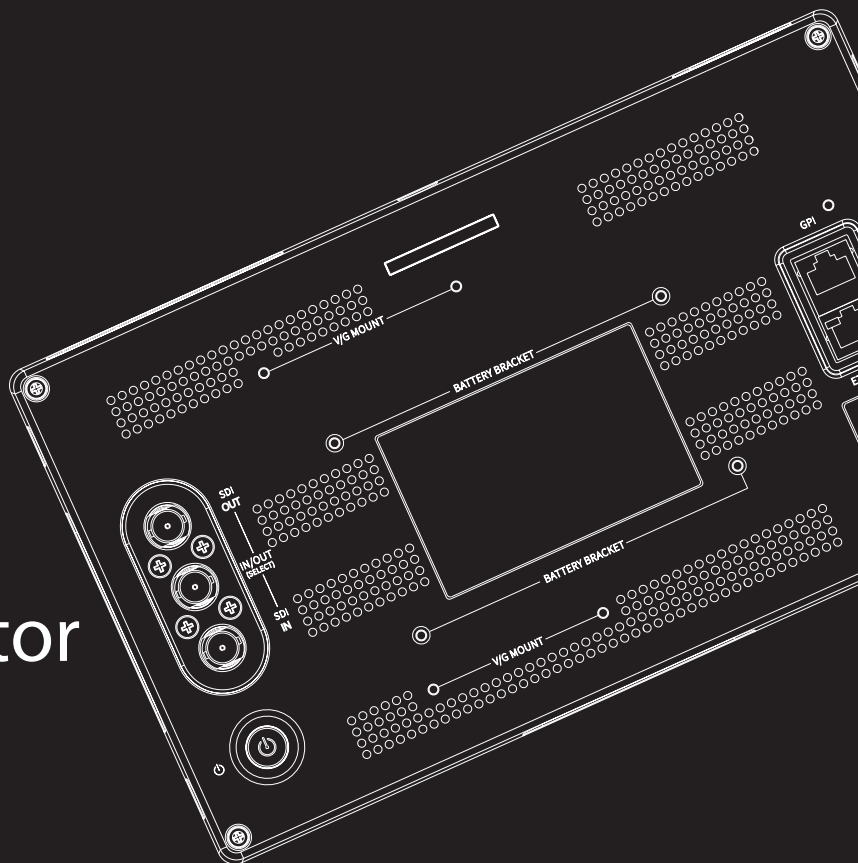



FCC (Federal Communications Commission)

This equipment has been tested and found to comply with the limits for class A digital device, pursuant to part 15 of the FCC Rules. These limits are designed to provide reasonable protection against harmful interference when the equipment is operated in a commercial environment.

This equipment generates, uses and can radiate radio frequency energy and if not installed and used in accordance with the instruction manual, may cause harmful interference to radio communications. Operation of this equipment in a residential to correct the interference at his own expense

CAUTION: Change or modifications not expressly approved by the manufacturer responsible for compliance could void the user's authority to operate the equipment.

Disposal of Old Electrical & Electronic Equipment

(Applicable in the European Union and other European countries with separate collection systems)

This symbol on the product or on its packing indicates that this product shall not be treated as household waste.

Instead it shall be handed over to the applicable collection point for the recycling of electrical and electronic equipment.

By ensuring this product is disposed of correctly, you will help prevent potential negative consequence for the environment and human health, which could otherwise be caused by inappropriate waste handling of this product. The recycling of materials will help to conserve natural resources.

CONTENTS

01	CAUTION	04p
02	MAIN FEATURES	06p
03	CONTROLS & FUNCTIONS	07p
04	MENU TREE & ADJUSTMENT	10p
05	MENU OPERATIONS	11p
	[1] PICTURE	11p
	[2] COLOR	12p
	[3] MARKER	15p
	[4] VIDEO	16p
	[5] WAVEFORM	18p
	[6] AUDIO	20p
	[7] SYSTEM	21p
06	BUTTON FUNCTIONS	23p
07	OTHER FUNCTIONS	24p
08	AVAILABLE SIGNAL FORMATS	34p
09	VIDEO SUPPORT RESOLUTION	35p
10	OUTPUT SIGNAL FORMATS	36p
11	PRODUCT SPECIFICATIONS	38p
12	OPTIONAL ACCESSORIES	39p

01 CAUTION

- Always use set voltage. (DC 6~34V)
- When using a DC Adapter other than the one supplied by the manufacturer, please be advised that the adapter with DC 12V/3A ~ 6A can be compatible with the monitor.
- All operating instructions must be read and understood before the product is operated.
- These safety and operating instructions must be kept in safe place for future reference.
- All warnings on the product and in the instructions must be observed closely.
- All operating instructions must be followed.
- Do not use attachments not recommended by the manufacturer. Use of inadequate attachments can result in accidents.
- This product must be operated on a power source specified on the specification label.
- If you are not sure of the type of power supply used in your home, consult your dealer or local power company. For units designed to operate on batteries or another power source, refer to the operating instructions.
- The power cords must be routed properly to prevent people from stepping on them or objects from resting on them. Check the cords at the plugs and product.
- In case of using other 12V DC adapters instead of the standard adapter provided by the manufacturer, please check the proper load capacity (or current capacity) and use an adapter with stable voltage.
- Do not overload DC outlets or extension cords. Overloading can cause or electric shock.
- Never insert an object into the product through vents or openings. High voltage in the product, and inserting an object can cause electric shock and/or short internal parts. For the same reason, do not spill water or liquid on the product.
- Do not attempt to service the product yourself. Removing covers can expose you to high voltage and other dangerous conditions. Request a qualified service person to perform servicing.
- If any of the following conditions occurs, unplug the power cord from the DC outlet, and request a qualified service person to perform repairs.
 - a. When the power cord or plug is damaged.
 - b. When a liquid was spilled on the product or when objects have fallen into the product.
 - c. When the product has been exposed to rain or water.
 - d. When the product does not operate properly as described in the operating instructions. Do not touch the controls other than those described in the operating instructions. Improper adjustment of controls not described in the instructions can cause damage, which often requires extensive adjustment work by a qualified technician.
 - e. When the product has been dropped or damaged.
 - f. When the product displays an abnormal condition.Any noticeable abnormality in the product indicates that the product needs servicing.
- In case the product needs replacement parts, make sure that the service person uses replacement parts specified by the manufacturer, or those with the same characteristics and performance as the original parts. Use of unauthorized parts can result in fire, electric shock and/or other danger.
- Upon completion of service or repair work, request the service technician to perform safety checks to ensure that the product is in proper operating condition.
- When mounting the product on a wall or ceiling, be sure to install the product according to the method recommended by the manufacturer.
- Unplug the power cord from the DC outlet before cleaning the product. Use a damp cloth to clean the product. Do not use liquid cleaners or aerosol cleaners.
- Unplug the power cord from the AC outlet if you do not use the product for considerably long time.

01 CAUTION

- Do not use the product near water, such as bathtub, washbasin, kitchen sink and laundry tub, swimming pool and in a wet basement.
- Keep the product away from direct rays of the Sun-light.
- Do not place the product on an unstable cart, stand, tripod or table. Placing the product on an unstable base can cause the product to fall, resulting in serious personal injuries as well as damage to the product. Use only a cart, stand, tripod, bracket or table recommended by the manufacturer or sold with the product. When mounting the product on a wall, be sure to follow the manufacturer's instruction. Use only the mounting hardware recommended by the manufacturer.
- When relocating the product placed on a cart, it must be moved with the utmost care.
- The power cord plug shall be connected to a MAINS socket outlet with a protective earthing connection.
- Infrared devices can cause noise or malfunction under condition as below.
 - Parts of the body come into contact with the infrared transmitter or acoustic device.
 - Obstacles can cause electrical changes if there is a partition in the middle or in the wall.
 - Exposure to radio interference from medical equipment, microwave ovens, wireless LAN devices, etc. with the same frequency band.
- Unplug the power cord from the AC outlet when happening any problem in the product.
- Sudden stops, excessive force and uneven floor surface can cause the product to fall from the cart.
- The vents and other openings in the cabinet are designed for ventilation. Do not cover or block these vents and openings since insufficient ventilation can cause overheating and/or shorten the life of the product. Do not place the product on a bed, sofa, rug or other similar surface, since they can block ventilation openings. This product is not designed for built-in installation; do not place the product in an enclosed place such as a bookcase or rack, unless proper ventilation is provided or the manufacturer's instructions are followed.
- In case of installation the product on the rack, the inside of the product would be overheated due to heat from other devices near by and the decrease of air circulation, which could damage to the monitor. To prevent the damage, please have enough space for the monitors and use fan to avoid heat and maintain the operating temperature. (Refer to the specification of the product).
- The LCD panel used in this product is made of glass. Therefore, it can break when the product is dropped or applied with impact. Be careful not to be injured by broken glass pieces in case the LCD panel breaks.
- Keep the product away from heat sources such as radiators, heaters, stoves and other heat generating products (including amplifiers).

WARNING



<Main Switch>

- | means Power on when pressing
- means Power off when pressing



<Beside critical components in circuit diagram>

To identify any terminal which is intended for connection to an external conductor for protection against electric shock in case of a fault, or the terminal of a protective earth (ground) electrode.



<Near the main terminal block>

This mark indicates the possibility of injury or damage to property.

02 MAIN FEATURES

Monitor contains the following features :

- **Compatible with various SDI signals formats (SD/HD/3G)**
 - This product is compatible with various SDI signals - 480i, 576i, 720p, 1080i, 1080p, 1080psf
- **HDMI(with HDCP) Signal**
 - This product is compatible with various HDMI signals.
- **HDMI To SDI / SDI To HDMI Conversion Output**
 - This product features an HDMI To SDI conversion output so that video source from HDMI In terminal can be output through SDI Out terminal.
 - The SDI To HDMI conversion output is also supported. The video source from SDI In terminal can be output through HDMI Out terminal.
- **All-in-one type system**
 - Slim and all-in-one type monitor that requires no additional accessories, for optimized space utilization.
- **Waveform/Vectorscope/Audio Level Meter Function**
 - Waveform & Vector Scope
 - Embedded Audio Level Meter
- **Audio Out**
 - Stereo Audio Out through phone Jack.
- **Knob Control**
 - Easy to adjust user configuration using the control knob on the top of the monitor.
- **BLUE ONLY / MONO / Focus Assist/ H/V Delay Function**
- **Range Error/Luma(Y') Zone Check(Color/Zebra Type) Function**
- **Internal Pattern Generator (0~100% Gray/ ColorBar+Pluge)**
- **Various Markers & Safety Areas**
 - Center Marker, Safety Area Marker, Marker Mat, Marker Size, Fit Marker, Thickness Adjustment function
- **1:1 Scan/Zoom Function**
 - Used to display the original image resolution without scaling to match a certain resolution or an aspect ratio.
 - Select 'Pixel to pixel' to display unscaled images, and select 'Zoom' to enlarge the original image.
 - Zoom Scroll Function (Left/Right, Top/Bottom)
- **Power**
 - Basically, the product is powered by a normal DC source.
 - The product can be battery-powered.
 - * DC 6~34V (Typical)
- **Additional features**
 - Camera Mounting Hole x 8, Screen Tally Function, VESA Mounting Standard, 450cd/m² Brightness, 1,000 : 1 Contrast, OSD user interface.

03 CONTROLS & FUNCTIONS

ALL PART

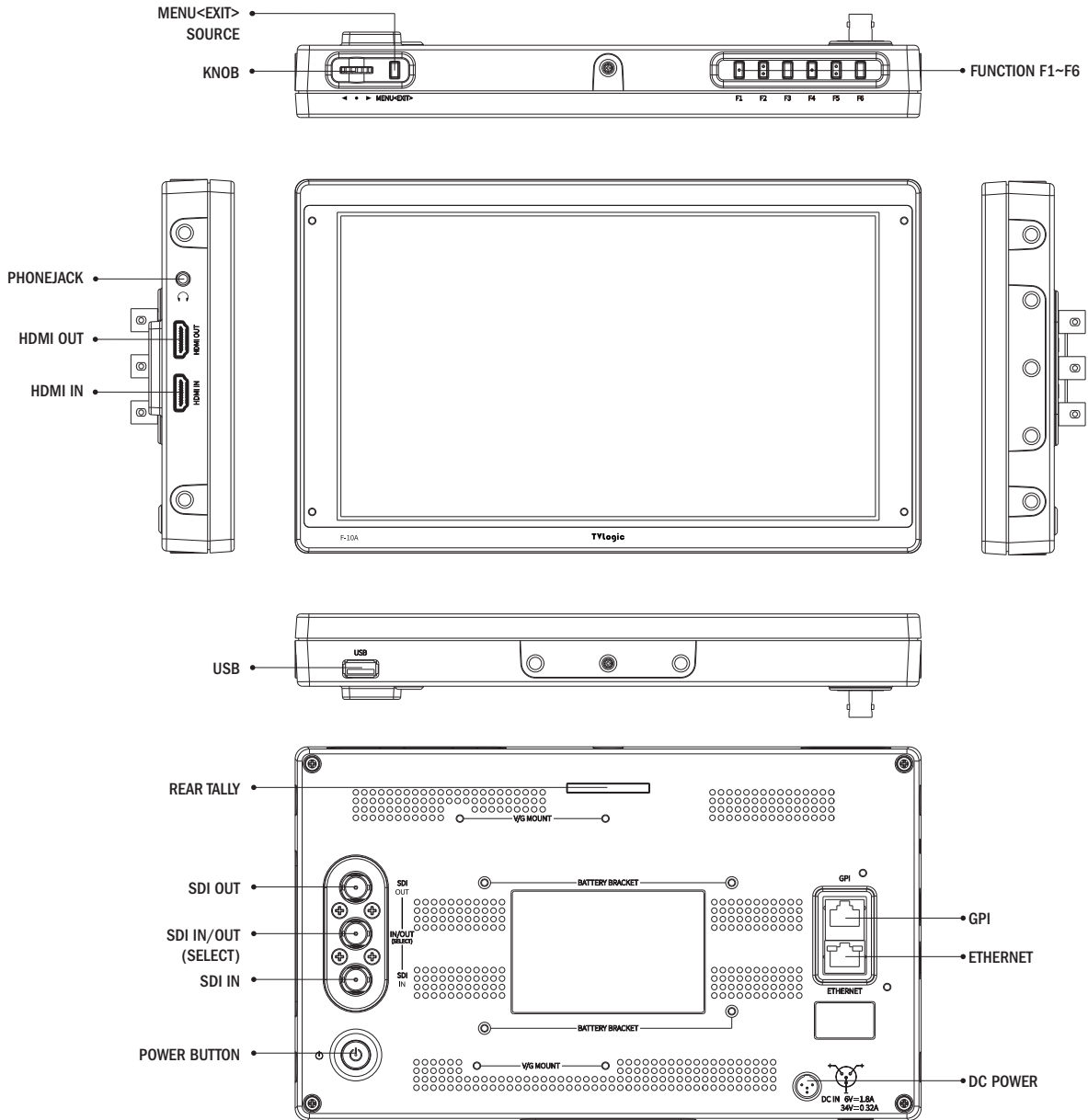

03 CONTROLS & FUNCTIONS

TOP & BOTTOM

- **[MENU/EXIT/SOURCE] Button**

- Used to activate the OSD menu.
- When the OSD menu is activated, press this button to exit from the menu.
- Press the button for more than 2 seconds to activate Input Select menu. (SDI, HDMI)
- Use the [ENCODER] Knob to change the Input Signal.

- **[UP/DOWN/ENTER] Knob**

- Used to move within the menu when OSD menu is activated, and is also used to decrease or increase the value of the selected feature.
- Press the knob to select the main menu and the sub menus.
- Press the button for more than 2 seconds to activate the HOT Key menu. (VOLUME / BRIGHT / CONTRAST / CHROMA / SHARPNESS / PEAKING BOOST)
- Press the button for less than 2 seconds to activate the PRESET function.

- **[F1]~[F3] Button**

- Press the button for less than 2 seconds to activate the function.
- Press the button for more than 2 seconds to activate Function Select menu. (Scan, Aspect, H/V delay, etc.)
- Press the button for more than 2 seconds to indicate previously selected function.
- Use the Knob to change the function.

- **[USB]**

- This terminal is used to upgrade the firmware or color calibration made by TVLogic.

03 CONTROLS & FUNCTIONS

SIDE & REAR

- **[HDMI IN]**
- Signal input terminal for HDMI signal.
- **[HDMI OUT]**
- Signal output terminal for HDMI signal.
- Video source from SDI input terminal can be converted to HDMI format.
- **[HEADPHONE] (Phonejack)**
- Used for Stereo Audio Output through Phone Jack. (video signals with embedded audio only)

- **[REAR TALLY]**
- Activates same as [SCREEN TALLY].
- **[DC POWER / TALLY] (XLR 4P)**
* Rated Power Input : DC 6V (1.8A) / 34V (0.32A)
* When using a DC Adapter other than the one supplied by the manufacturer, please be advised that the adapter with DC 12V/3A ~ 6A can be compatible with the monitor.

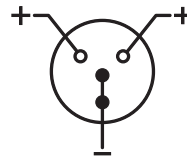

- **[SDI IN] (BNC)**
- Signal input terminal for HD/SD/3G SDI signal.
- **[SDI IN/OUT] (BNC)**
- Can be used as SDI IN or SDI OUT depending on the menu setting.
- **[SDI OUT] (BNC)**
- Signal output terminal for HD/SD/3G SDI signal.
- Video source from HDMI input terminal can be converted to SDI format.
- **[POWER] Switch**
- Used to turn the power on and off.

<Warning!!>

When using the product make sure to ground, whenever possible, before connecting the input signal cable in order to prevent any possible damage to the product or connected devices. The damage may include signal noise, malfunction of main board or display panel. And the connected devices such as camera or video source player may also be influenced through signal cable. Please check if the AC power source and the power extender or power distributor is grounded.

04 MENU TREE & ADJUSTMENT

MENU TREE & MENU CONTROL & MENU CONTROL SEQUENCE

[1] MENU TREE

- OSD(On-Screen Display) Menu helps to use various different functions.
- This Picture is the menu structure for F-10A

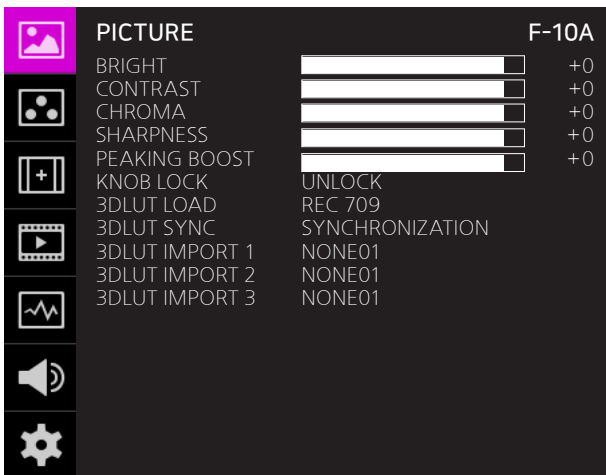

[2] MENU CONTROL

- User may control various functions using the MENU button and the Knob on the top of the monitor.

[3] MENU CONTROL SEQUENCE

- Menu control sequence follows the order below.
 1. Press MENU button to activate the OSD menu.
 2. Move to a desired menu using the Knob.
 3. Press the Knob to select a menu and move to select a sub-menu by scrolling the Knob.
 4. Press the Knob to select the desired sub menu. (The selected sub-menu will be highlighted)
 5. Press the ENTER button or the MENU button to save the new value after adjusting the value by scrolling the Knob.
 6. Press MENU button to return to previous menu and if there is no previous menu, the OSD menu will be removed from the screen.

05 MENU OPERATIONS

[1] PICTURE

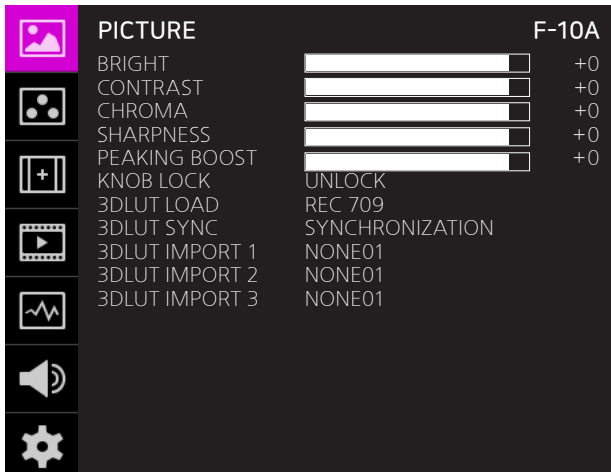

- BRIGHT**
 - Used to set the brightness(=offset) level from -100 to 100.
 - * Brightness can be adjusted by using the Knob on the top of the monitor.
- CONTRAST**
 - Used to set the contrast(gain) level from -100 to 100.
 - * Contrast can be adjusted by using the Knob on the top of the monitor.
- CHROMA**
 - Used to set the saturation level from -50 to 50.
 - * Chroma can be adjusted by using the Knob on the top of the monitor.
- SHARPNESS**
 - Used to set the Sharpness level from 0 to 24.
 - * Sharpness can be adjusted by using the Knob on the top of the monitor.
- PEAKING BOOST**
 - Used to set the Peaking Boost level from 0 to 24.
 - * Peaking Boost can be adjusted by using the Knob on the top of the monitor.
- KNOB LOCK**
 - Locks the Knob control.
- 3DLUT LOAD**
 - Used to apply the internally stored 3DLUT.
 - Maximum 3 x 3DLUT files can be stored.
 - The file name can be set up to 20 characters including the extension.
- 3DLUT SYNC**
 - Used to load a list of available 3DLUT files currently stored in the FLASH MEMORY.
 - Available 3DLUT formats are Cube, GV Lut, Quantel, Davinci and Assimilate Scratch.
 - Available sizes of the 3DLUT are 17 or 33.
- 3DLUT IMPORT 1/2/3**
 - Used to save the 3DLUT stored in the external memory to the internal memory 1/2/3 area.
 - Once saved, the 3DLUT can be maintained even when the power is turned ON/OFF.
 - The file name can be set up to 20 characters including the extension.

05 MENU OPERATIONS

[2] COLOR

COLOR		F-10A
STANDARD	UHD	
VIDEO RANGE	LIMITED 109	
PEAK LUMINANCE	100	
BLACK LEVEL	0.001	
COLOR GAMUT	BT.2020	
COLOR TEMP	6500K	
EOTF	2.4	
LOCAL DIMMING	OFF	
EETF	OFF	
HLG SG	OFF	
SG		
THROUGHOUT	OFF	
CAM LUT	OFF	
CAM LUT THR	OFF	

PAGE (1/2)

- **STANDARD**

 - Used to select the color and dynamic range of the screen.
 - Available options are HD, UHD, DCI-P3, PQ, HLG, SLog3 and User1/2/3.
 - * Activates only in the User1/2/3 mode.
- **VIDEO RANGE**

 - Used to select the range of digital video signal.
 - * FULL : Input signal 0~255 (8bit), 0~1023 (10bit) (When connecting the PC)
 - * LIMITED109 : Input signal Y': 16~235, CbCr: 16~240 (8bit)/ Y': 64~940, CbCr: 64-960 (10bit)
- **PEAK LUMINANCE**

 - Used to select the Peak Luminance of the monitor.
 - Available options are 100, 200, 300, 400, 500, 600, 700, 800, 900, 1000, 2000, 4000 and 10000.
 - Activates only in the User1/2/3 mode.
- **BLACK LEVEL**

 - The minimum black level of the video signal can be set differently depending on the performance of the monitor or the lighting environment. For example, the lowest luminance that the F-7H mk2 can display is 0.002, but it is necessary to adjust the offset level to about 0.2nit when using under bright light.
 - At this time, when the black level is set to 0.2, dark gradations below 0.2 nit are expressed without crushing.
 - Activates only in the User1/2/3 mode.
- **COLOR GAMUT**

 - Used to select the standard color gamut.
 - Available options are BT.709, DCI-P3, BT.2020 and Native.
 - * The submenus may be activated in the User1/2/3 mode only.
- **COLOR TEMP (Color Temperature)**

 - Controls the color temperature.
 - Available options are 6500K, 9300K and User.
 - * The submenus may be activated in the User1/2/3 mode only.
- **EOTF (Electro-Optical Transfer Function)**

 - Electrophotonic conversion Functions(ex: Gamma or HDR curve).
 - Available modes are 2.2, 2.4, 2.6, PQ, HLG and SLOG3.
 - * The submenus may be activated in the User1/2/3 mode only.
- **LOCAL DIMMING**

 - Used to set the Local Dimming Backlight mode.
 - This mode is supported by the local dimming backlight model (LUM-310R) and does not support F-10A.

05 MENU OPERATIONS

[2] COLOR

COLOR		F-10A
STANDARD	UHD	
VIDEO RANGE	LIMITED 109	
PEAK LUMINANCE	100	
BLACK LEVEL	0.001	
COLOR GAMUT	BT.2020	
COLOR TEMP	6500K	
EOTF	2.4	
LOCAL DIMMING	OFF	
EETF	OFF	
HLG SG	OFF	
SG		
THROUGHOUT	OFF	
CAM LUT	OFF	
CAM LUT THR	OFF	

PAGE (1/2)

• SG (System Gamma)

- The System Gamma of HLG is automatically calculated and displayed according to the set peak luminance.
- Activates only when the EOTF is set to HLG and the HLG SG is Auto.

• CAM LUT (Camera LUT)

- Used to change the Camera LUT.
- Available LUTs are OFF, LOG-C, C-LOG, S-LOG 1,2,3 and REDGamma 3,4.

• CAM LUT THROUGH (Camera LUT Throughout)

- Apply the currently applied LUT to Throughout.

• EETF (Electrical-Electrical Transfer Function)

- Used to display the HDR image(without clipping) within the actual luminance range (black level and peak luminance) that the monitor can express. In the Auto mode, the HDR image is converted within the range of set peak luminance and black level. In the OFF mode, the video signal outside of the set range is clipped.
- Available modes are OFF and AUTO.
- Available only when the EOTF is set to PQ or SLOG3.

* The submenus may be activated in the User1/2/3 mode only.

• HLG SG (HLG System Gamma)

- Used to set the System Gamma of HLG mode.
- In the Auto mode, the value of the System Gamma changes automatically according to the previously set peak luminance. When it is OFF, the value is set to default value of 1.2.
- Activates only when the EOTF is set to HLG.

* The submenus may be activated in the User1/2/3 mode only.

05 MENU OPERATIONS

[2] COLOR

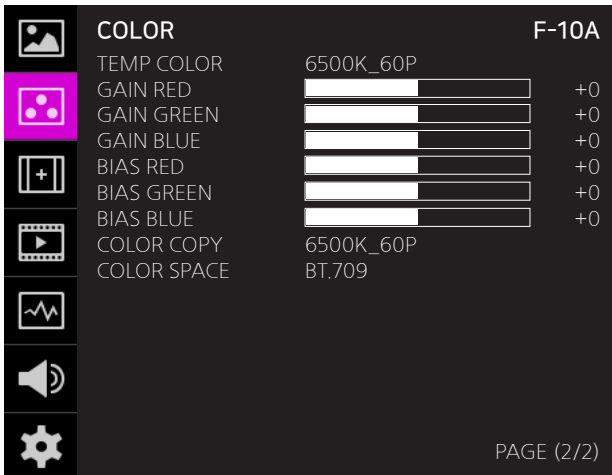

• COLOR SPACE

- Used to select the standard color space.
- Available options are BT.709, DCI-P3, BT.2020 and Native.

• TEMP COLOR (Color Temperature)

- Controls the color temperature and allows instant access to preset the color temperature settings.
- Available color temperatures are 6500K, 9300K and User1/2/3.
- * In User 1/2/3 modes, user can define custom RGB GAIN, BIAS (=Offset) and Color Copy values.

• GAIN RED / GREEN / BLUE

- Used to set Red/Green/Blue Gain(or Picture, Contrast) level from -256 to 255.
- * Only available in User 1/2/3 mode.

• BIAS RED / GREEN / BLUE

- Used to set Red/Green/Blue Bias(or Offset, mainly affects on Black level) from -100 to 100.
- * Only available in User 1/2/3 mode.

• COLOR COPY

- Used to copy the R/G/B Gain value of pre-stored color temperature settings.
- In User mode, find and select the color temperature and press the Knob to copy and apply the Gain value to GAIN RED, GAIN GREEN, GAIN BLUE.
- * Only available in User 1/2/3 mode.

05 MENU OPERATIONS

[3] MARKER

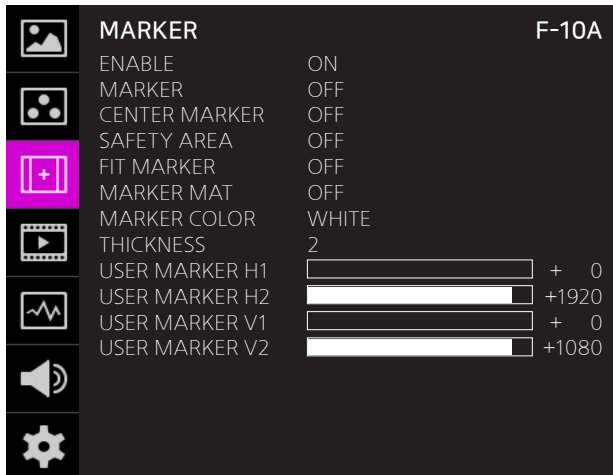

- **ENABLE**
 - Used to activate the Marker function.
- **MARKER**
 - Available Marker types are OFF, 16:9, 4:3, 4:3 ON AIR, 15:9, 14:9, 13:9, 1.85:1, 2.35:1, 1.85:1& 4:3 and USER.
- **CENTER MARKER**
 - Displays the Center Marker on the screen.
- **SAFETY AREA**
 - Used to select to display and controls the size and availability of the Safety Area.
 - Available sizes are 80%, 85%, 88%, 90%, 93%, 100%, EBU ACTION 16:9, EBU GRAPHIC 16:9, EBU ACTION 14:9, EBU GRAPHIC 14:9, EBU ACTION 4:3 and EBU GRAPHIC 4:3.
- **FIT MARKER**
 - Used to activate or inactivate the Fit Marker function.
 - When the Marker type is selected in the Marker menu, a border line of the Safety Area will be displayed inside the Marker. Images below show the difference between Fit Marker ON and OFF.

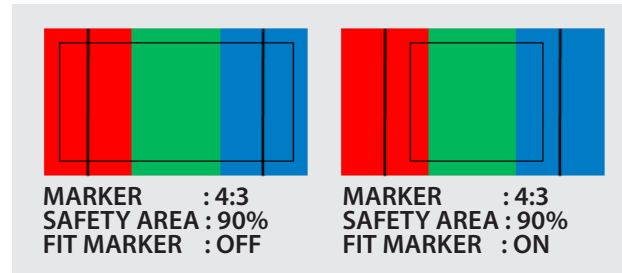

- **MARKER MAT**
 - Used to set the darkness level outside of the MARKER area from OFF(transparent) to 7(Black).
 - The bigger the value, the darker the color.
- **MARKER COLOR**
 - Used to set the color of the MARKER lines.
 - Available colors are white, gray, black, red, green and blue.
- **THICKNESS**
 - Used to set the thickness of the MARKER lines.
 - Thickness level is from 1 to 7 by the pixel unit.
- **USER MARKER H1**
 - Used to set the position of the first horizontal marker line.
 - Displayed when the MARKER menu is set to USER.
- **USER MARKER H2**
 - Used to set the position of the second horizontal marker line.
 - Displayed when the MARKER menu is set to USER.
- **USER MARKER V1**
 - Used to set the position of the first vertical marker line.
 - Displayed when the MARKER menu is set to USER.
- **USER MARKER V2**
 - Used to set the position of the second vertical marker line.
 - Displayed when the MARKER menu is set to USER.

05 MENU OPERATIONS

[4] VIDEO

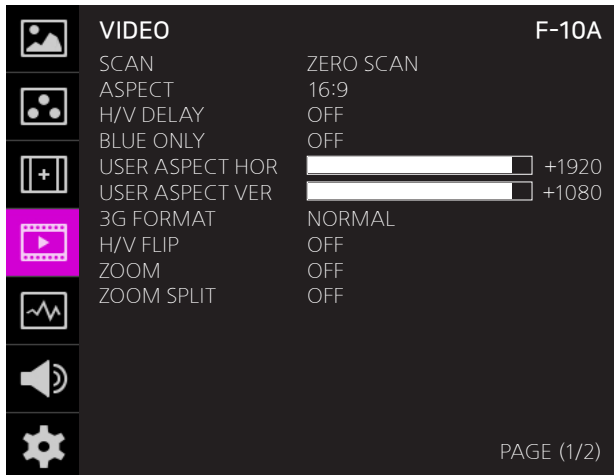

- **SCAN**

 - Used to change the Scan mode. Scroll up and down using the Knob and the mode will change as the following sequence. [Zero Scan] -> [Over Scan] -> [Pixel-To-Pixel] -> [User Aspect]
 - * [USER ASPECT]: User can control the aspect ratio by adjusting width and height of the display.
 - * See section "7. Other Functions [1] User Aspect" for more information.
- **ASPECT**

 - Used to change the Aspect Ratio.
 - Regardless of the original Aspect ratio of the input signal, the Aspect Modes are changed as follow sequence. : [16:9][4:3][2.35:1][1.85:1][15:9][16:10][Anamorphic1.3x][Anamorphic1.5x][Anamorphic2.0x][Auto]
 - * [Auto] mode enables the Aspect Ratio of the output signal to be synchronized to the original Aspect Ratio of the input signal.
- **H/V DELAY**

 - Used to monitor the Blanking area of H sync and V sync.
- **BLUE ONLY**

 - Used to switch in the order of [Off]-[Blue Only]-[Mono]-[Off].
 - Press the button to remove red and green components from the input signal and display blue component only.
 - Press the button again to switch to mono-chrome mode which has no chroma signal.
- **USER ASPECT HORIZONTAL/USER ASPECT VERTICAL**

 - Activated only when the [SCAN] mode is set to [User Aspect] .
 - User can adjust the Horizontal and Vertical size of the screen.
 - See section "7. Other Functions [1] User Aspect" for more information.
- **3G FORMAT**

 - Used to select 3G-SDI A/B input format among NORMAL MODE(AUTO - A 422 10BIT_YCbCr 50/60P), A 444 10/12BIT_YCbCr, A 444 10/12BIT_RGB, A 422 12BIT_YCbCr, B 444 10/12BIT_YCbCr, B 444 10/12BIT_RGB, B 422 12BIT_YCbCr, B 422 10BIT_YCbCr 50/60P.
 - In NORMAL MODE, automatically detected when Payload signal is contained.
- **H/V FLIP**

 - Allows the displayed image to be flipped horizontally or vertically.
 - This feature provides flexible mounting options for camera operators.
 - In the [AUTO] mode, the vertical FLIP operates automatically according to the position of the unit.
 - Activates in the order : [H Flip]-[V Flip]-[H/V Flip]-[AUTO]
- **ZOOM**

 - Used to magnify the image up to 90% on a pixel basis and display on full screen.
 - * (e.g., 10% Zoom : If the input signal's resolution is 1920 x 1080, only 90% (1728(H) x 972(V)) of the image would be shown on full screen without the remaining 10% (192(H) x 108(V)) of the image.)
 - * See section "7. Other Functions -> [4] Zoom" for more information.
- **ZOOM SPLIT**

 - Used to magnify the image.
 - Used to zoom the specified area sequentially.
 - Designable areas are Left-Top, Right-Top, Left-Bottom, Right-Bottom and Center.

05 MENU OPERATIONS

[4] VIDEO

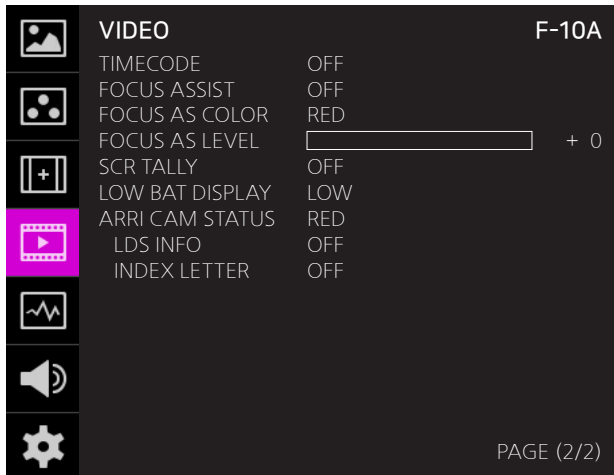

- **TIMECODE**
 - Used to set the Time Code.
 - Available modes are [Off], [VITC], and [LTC].
- **FOCUS ASSIST**
 - Focus Assist helps the shooters to easily find out the exact area in the picture with good focus, simply by adding colors on the shape or boundaries of the object in the picture.
 - Activates in order of [Mono On]-[Color On]- [Off]
 - * [Color On] : Only the boundary of the area with good focus is displayed with the designated color.
 - * [Mono On] : The boundary of the area with good focus is colored with the designated color, while the rest of the areas(pixels) have only Y'(Luma) signals to be black & white image.
 - * See section "7. Other Functions [6] Focus Assist" for more information.
- **FOCUS AS COLOR (Focus Assist Color)**
 - Used to select a color for Focus Assist among red, green and blue.
 - This feature is available only when the Focus Assist mode is activated.
- **FOCUS AS LEVEL (Focus Assist Level)**
 - Used to set the edge difference value between the edges in an image.
 - Available values are from 0 to 100. Larger the value the more sophisticated the detail detection.
 - Designated color is displayed when the difference of the edges exceeds the previously set value.
 - This feature is available only when the FOCUS ASSIST mode is activated.
- **SCR TALLY (Screen Tally)**
 - Used to set Tally operation according to the input level of TALLY IN terminal which is among the terminals of XLR 4P connector in the rear.
- **LOW BAT DIS (Low Battery Display)**
 - Used to set Low Battery Display function.
 - When the battery becomes weak, [Low Battery] sign is indicated on the OSD.
- **ARRI CAM STATUS**
 - Used to display the camera status information provided by ARRI ALEXA camera on the OSD.
 - When the Arri Cam Status is activated, the screen will be squeezed (1742 x 980).
- **LDS INFO (Lens Data System Information)**
 - Used to set the information display of the Lens Data System information.
 - The information is displayed in the order : [Lens name] - [Focal length] - [Iris] - [DOF Min] - [Focus distance] - [DOF Max].
- **INDEX LETTER**
 - Used to set the monitor index letter on the upper right.

05 MENU OPERATIONS

[5] WAVEFORM

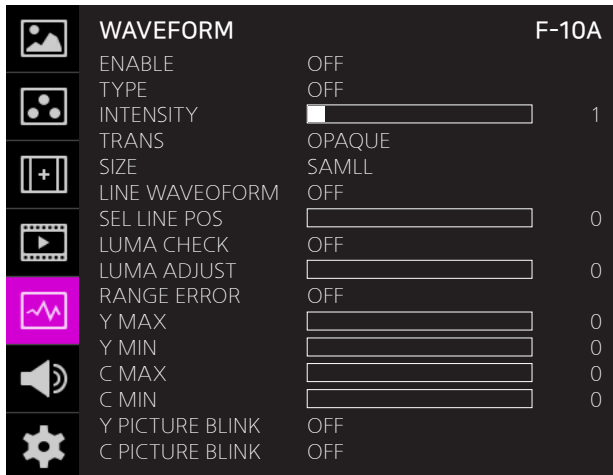

- **ENABLE**

 - Used to activate/ deactivate the Waveform which is selected in the Waveform/Vectorscope Type menu.
- **TYPE**

 - This function sets the Waveform and Vectorscope.
 - Available options are different according to the Input signal.
 - Activates in the order: YCbCr: Off - Waveform
 - Vectorscope - Waveform Wide - Waveform YCbCr - RGB(Conv.)-Wave_Vector - Vector_YCbCr
 - Full Waveform(Y) - Full Vectorscope.
- **INTENSITY**

 - Used to set the brightness level of the Waveform/ Vectorscope display from 1 to 63.
 - The higher the number the brighter the waveform will be.
- **TRANS (Transparency)**

 - Used to select the transparency option of the Waveform/ Vectorscope between Opaque and Blend.
 - Even if the option is set to [Opaque], it will automatically turn to [Blend] when the main OSD overlaps the waveform/vectorscope. And turns back to [Opaque] when the main OSD disappears.
- **SIZE**

 - Adjust the size of the Waveform or Vectorscope.
 - Can select among [NORMAL] and [LARGE].
- **LINE WAVEFORM**

 - This item is utilized to display the entire data or one line data on the Waveform.
- **SEL LIN POS (Select Line Position)**

 - Used to select specific Vertical Line for Waveform/ Vectorscope.
 - This is available when LINE Waveform is activated.
 - Use the Knob to select a desired vertical line.
 - Control range varies according to the resolution of the input SDI signal.
 - * PAL : Min. 1, Max. 625
 - * NTSC : Min. 1, Max. 525
 - * 720p : Min. 1, Max. 750
 - * 1080i : Min. 1, Max. 1125
 - * 1080p : Min. 1, Max. 1125
- **LUMA CHECK**

 - Displays the Luma(Y') level of the input image in colors.
 - Can select between [Color Pattern] or [Zebra Pattern].
 - Each pixel's Y' analyzed and changed to a certain color or zebra pattern according to the Index on the right side of the screen.
 - When a pixel's Y' level is under 0%(16), the color / diagonal line will be colored Green.
 - When the pixel's Y' level is over 100%(235), the color / diagonal line will be colored Red.
 - When the Y' level of a pixel is between 0~100%, the pixel is displayed with Gray, except for selected Luma Zone.
 - In the [Color Pattern] mode, a 5% zone of the selected Y' level will be colored Pink(5%) and $\pm 10\%$ will be colored Yellow(-10% from Pink) and Cyan(+10% from Pink).
 - In the [Zebra Pattern] mode, $\pm 5\%$ of the selected Y' Level will be displayed with diagonal lines.

05 MENU OPERATIONS

[5] WAVEFORM

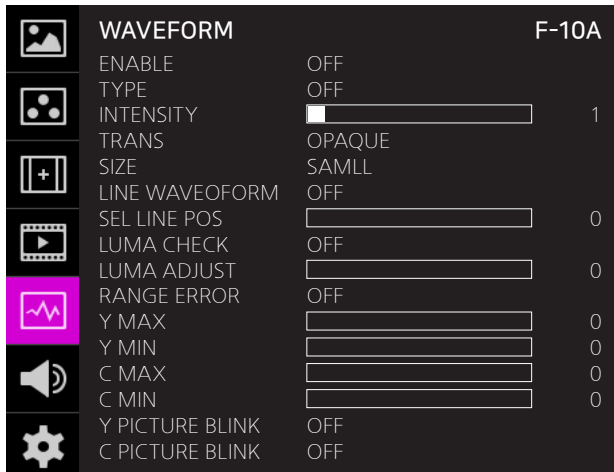

• LUMA ADJUST

- Used to set the Y' level to be colored Yellow, Pink and Cyan in [Color Pattern] mode, or to set Y' level zone to be displayed with diagonal lines in [Zebra Pattern] mode simply by scrolling the Knob.
- Available values are 0w ~ 100%.
- * See section "7. Other Function [5] Luma(Y') Zone Check" for more information.

• RANGE ERROR

- Used to set whether or not to activate Y MAX, Y MIN, C MAX, C MIN, Y PICTURE BLINK and C PICTURE BLINK functions.
- The values of Y MAX, Y MIN, C MAX, C MIN are indicated in Waveform/Vectorscope.
- If [Y PICTURE BLINK] or [C PICTURE BLINK] is enabled, the section of image that exceeds the selected values of Y MAX, Y MIN, C MAX and C MIN shall blink.
- * In the case of RGB input, Range Error is not supported.
- * See section "7. Other Function [7] Range Error" for more information.

• Y MAX

- Used to set the maximum Luma(Y') level from 0 to 255.
- Pixels with values exceeding the max Y' level will blink on the screen, and be displayed in red on the Waveform.

• Y MIN

- Used to set the minimum Luma(Y') level from 0 to 255.
- Pixels with values exceeding the max Y' level will blink on the screen, and be displayed in red on the Waveform.

• C MAX

- Used to set the maximum chroma(C') level from 0 to 255.
- Pixels with values exceeding the max Y' level will blink on the screen, and be displayed in red on the Waveform.

• C MIN

- Used to set the minimum chroma(C') level from 0 to 255.
- Pixels with values exceeding the max Y' level will blink on the screen, and be displayed in red on the Waveform.

• Y PICTURE BLINK

- Used to set whether or not to blink pixels with values exceeding Y MAX and Y MIN.

• C PICTURE BLINK

- Used to set whether or not to blink pixels with values exceeding C MAX and C MIN.

05 MENU OPERATIONS

[6] AUDIO

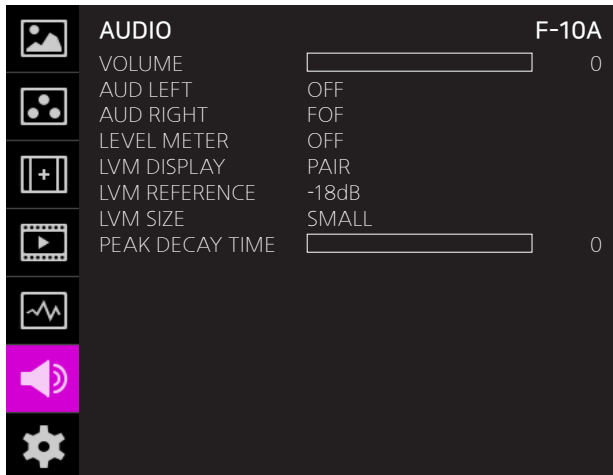

- **VOLUME**

 - Used to control the output volume for the [AUDIO OUT] on the back of the monitor.
 - Control range is from 0 to 30.
- **AUD LEFT (Audio Left)**

 - Used to set embedded audio channel for left audio out of [AUDIO OUT] terminal on the back of the monitor.
 - Available values are between CH1~CH16 and Ext..
 - * In the HDMI mode, Left is set to CH1.
- **AUD RIGHT(Audio Right)**

 - Used to set embedded audio channel for right audio out of [AUDIO OUT] terminal on the back of the monitor.
 - Available values are between CH1~CH16 and Ext..
 - * In the HDMI mode, Right is set to CH2.
- **LEVEL METER**

 - Used to set the Level Meter for the embedded audio.
 - Available options are :
SDI Input : [Off]-[16CH(Hor.)]-[16CH(Ver.)]
HDMI Input: [Off]-[2CH(Hor.)]-[2CH(Ver.)]
 - * 16 CH(HOR.) : Displays 8 channels on top left and 8 channels on top right of the screen horizontally.
 - * 16 CH(VER.) : Displays 8 channels on center left and 8 channels on top right of the screen vertically.
- **LVM DISPLAY (Level Meter Display)**

 - Used to set the display method for audio level meter.
 - Available modes are Group and Pair.
 - * In the HDMI mode, the mode is set to Pair.
- **LVM REFERENCE (Level Meter Reference)**















 - Display the default audio level meter value,
 - Available options are -18dB and -20dB.
 - Audio level meter within selected value turns to green and exceeded audio level is displayed in yellow.
 - Audio level exceeding -4dB is displayed in red.
- **LVM SIZE (Level Meter Size)**

 - Used to control the size of the audio level meters.
 - Available options are NORMAL and LAGRE.
- **PEAK DECAY TIME**

 - Sets the reduction time for max value indication of audio signals.
 - Control range is from MIN 0 to MAX 100. Bigger number means a longer display time for max value.

05 MENU OPERATIONS

[7] SYSTEM

SYSTEM		F-10A
	DEFAULT	OFF
	LUMINANCE	<input type="range" value="100"/> 100
	INTERNAL PAT	OFF
	DISPLAY ENABLE	OFF
	ECO SAVING	OFF
	SW UPGRADE	OFF
	DHCP	STATIC
	IP ADDRESS	192.168.1.80
	SUBNET MASK	255.255.255.0
	GATEWAY	192.168.1.1
	PORT	10262
	APPLY	OFF
	MAC ADDRESS	FF:FF:FF
	VERSION	SW 00 FPGA 00 BOARD 00
	SERIAL NUM	12345678 PAGE (1/2)

- **DEFAULT**
 - Used to initialize OSD values to factory default.
 - Available modes are DEFALUT and FACTORY.
 - In the DEFALUT mode, except for the stored 3D LUT, all values are initialized.
 - In the FACTORY mode, all values are initialized to factory default.
- **LUMINANCE**
 - Used to indicate the current Luminance value .
 - In the case of System Default, the value returns to factory default(after color calibration).
 - Available values are from 0 to 50.
- **INTERNAL PAT (INTERNAL PATTERN)**
 - Generates ColorBar, Pludge and Grayscale Pattern internally.
 - Selectable range for Gray Pattern is from 0% to 100% with 5% increment.
 - * See section "7. Other Function -> [12] Internal Pattern" for more information.
- **DISPLAY ENABLE**
 - Used to set the LUMINANCE to the minimum value when the time set in the still image output is exceeded.
 - When video is output or the MENU button is pressed, the LUMINANCE is reset to the original value.
 - Settable options are ON, 5MIN, 10MIN, 20MIN and 30MIN.
 - In the Function Key, the screen can be turned ON/OFF immediately by user's choice.
- **ECO SAVING**
 - Used to save power consumption automatically when there is no monitor signal.
 - When the signal is supplied, the brightness of the monitor will be changed to the set value.
- **S/W UPGRADE**
 - Used to upgrade the firmware using USB (Thumb drive).
 - * See section "7. Other Functions -> [13] Firmware Upgrade" for more information.
- **DHCP**
 - Used to activate/deactivate the DHCP function.
- **IP ADDRESS / SUBNET MASK / GATEWAY**
 - Used to set the IP Address connected to a Monitor.
- **PORT**
 - Used to set the port number of the monitor.
 - Default is set to 10262.
- **APPLY**
 - Use to apply changed value of IP Address, Subnet mask, Gateway and Port no.
- **MAC ADDRESS**
 - Displays the MAC Address.
- **VERSION**
 - Displays current firmware version.
- **SERIAL NUM (Serial Number)**
 - Displays the serial number of the monitor.

05 MENU OPERATIONS

[7] SYSTEM

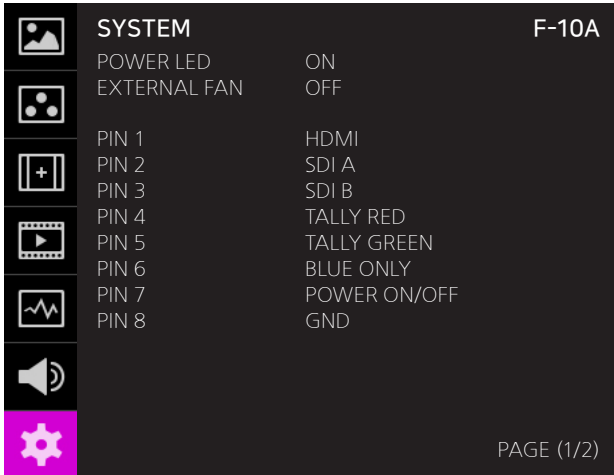

• POWER LED

- Used to set the POWER LED ON/OFF.
- When is set to ON, the LED is always on and when it is OFF, the LED is off after booting.

• EXTERNAL FAN

- Connect the FAN to the USB port of the monitor and set the 'EXTERNAL FAN' mode to 'FAN ON'. (Can also be set in Function Key).
- Press the button of the FAN to adjust the wind speed.
- OFF : The LED indicator light up in red and the FAN turns off. When powering on the FAN for the first time, it is set to OFF mode.
- FAST : The LED indicator light up in green and the FAN operates at high speed.
- SLOW : The LED indicator light up in orange and the FAN operates at slow speed.
- * When using 'Calibration' or 'USB Upgrade' via the USB port, set

• This item activates/ inactivates the REMOTE function.

- The user may designate a function for each pin and each pin's default setting is as follows.
- The default settings are as follows:
 PIN 1 : HDMI CHANNEL
 PIN 2 : SDI-A CHANNEL
 PIN 3 : SDI-B CHANNEL
 PIN 4 : TALLY RED
 PIN 5 : TALLY GREEN
 PIN 6 : BLUE ONLY
 PIN 7 is POWER ON/OFF use only, PIN 8 is GND

REMOTE (RJ-45)

- 1: Pin1
- 2: Pin2
- 3: Pin3
- 4: Pin4
- 5: Pin5
- 6: Pin6
- 7: Pin7
- 8: GND

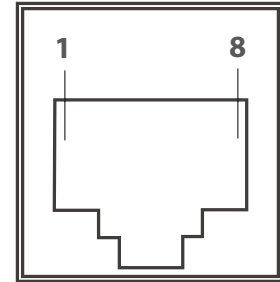

06 BUTTON FUNCTIONS

INPUT BUTTON & FUNCTION KEY SET BUTTON

[1] INPUT BUTTON

SDI A
SDI B
HDMI
NO VIDEO

- **F-10A unit is capable of processing SDI/HDMI Input signal.**

1. Press the [MENU < EXIT >] button on the front of the monitor for more than 2 seconds and activate the OSD menu as shown on the below.
2. Input resolution displays on the bottom of the OSD screen.
3. Press the [MENU < EXIT >] button again to remove the OSD menu from display.

* If no image displays after selecting the desired input mode, check and make sure that your connection is not lost or disconnected.

[2] FUNCTION KEY SET BUTTON

F1 FUNC SEL

SCAN
ASPECT
MARKER
H/V DELAY
BLUE ONLY
ZOOM
ZOOM SPLIT
FREEZE
AUDIO LVM
TIME CODE
FOCUS ASSIST
WAVEFORM
LUMA(Y) ZONE
RANGE ERROR
H/V FLIP
MAX BRIGHTNESS
CAMERA LUT
DISPLAY ENABLE
INPUT SELECT
ARRI METADATA
EXTERNAL FAN

- **Used to make a quick setting of the Function Key.**

1. Press the function button(F1~F6) on the front of the monitor for more than 2 seconds and activate the OSD menu as follows.
2. Move to a desired function with the Knob and press the Knob to select.
3. Once the function is set, press the Function button(F1~F6) to activate the function.

07 OTHER FUNCTIONS

[1] USER ASPECT

- Used to adjust the Width/Height display ratio.

1. Select [Aspect] mode in the OSD menu by pressing the function button on the right top of the monitor to activate the [USER ASPECT] mode.
2. After the activation, press the Knob to begin controlling. Adjust the ratio using the knob.

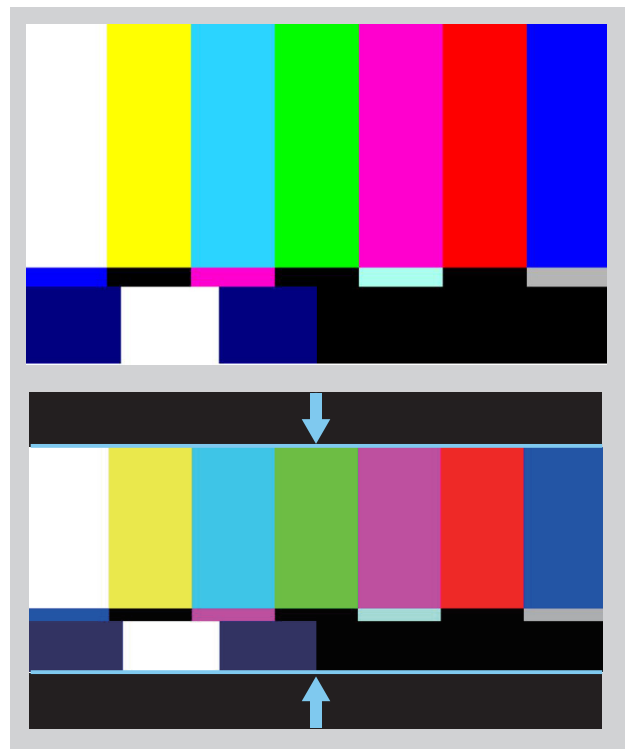
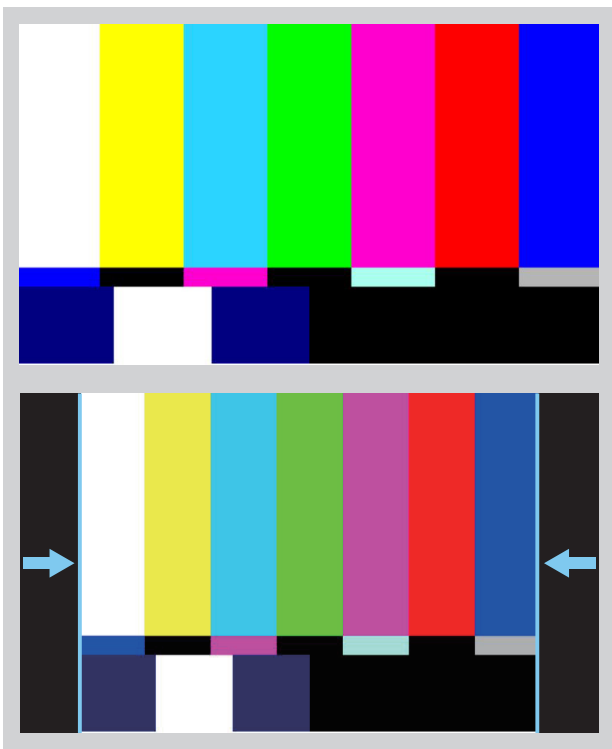
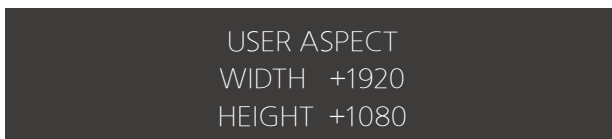

- Adjust the ratio using the Knob.
- Control range for width: 0~1920.
- Control range for height : 0~1080.
- The size-adjusted picture always stays in the center of the screen.
- The size can be adjustable with 2 increment and decrement.

* To adjust the 16:9 aspect ratio of 1920X1080 resolution into 2.35:1 aspect ratio, adjust the width and height as 1280 x 544.

07 OTHER FUNCTIONS

[2] WAVEFORM / VECTORSCOPE

• WAVEFORM Y

- Displays the Luma(Y') component of the input signal into waveform.

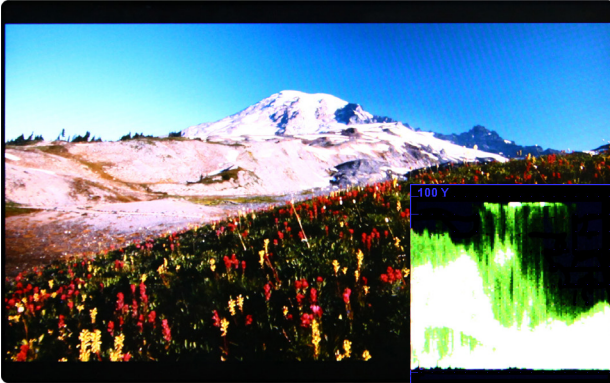

- The Waveform/Vectorscope function can be used only when the input signal is YUV.
- In the case of RGB input, Waveform RGB is supported.
- Available modes in the YUV signal :
 - WAVEFORM Y
 - VECTORSCOPE
 - WAVEFORM Wide
 - WAVEFORM Y Cb Cr
 - WAVE_VECTOR
 - VECTOR_YCbCr
 - FULL WAVEFORM(Y)
 - FULL VECTORSCOPE

• WAVEFORM Cb, Cr

- Displays the Cb, Cr components of the input signal into waveform.

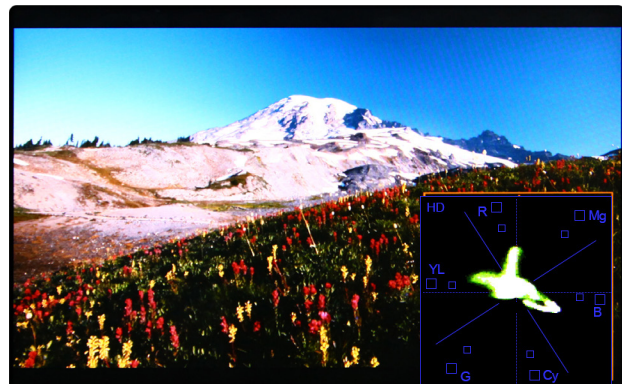
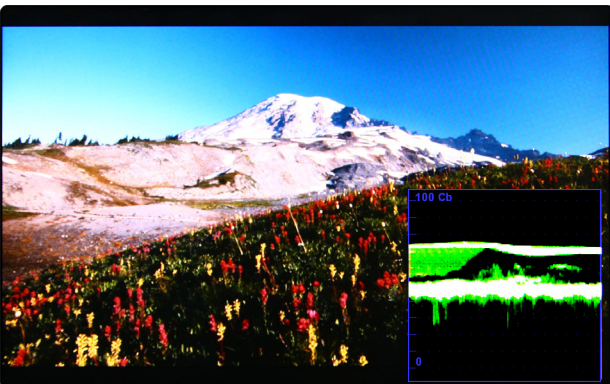

• VECTORSCOPE

- Displays the color components 'B-Y' and 'R-Y' of the input signals onto the X-Y axis.
- Two different types of Vectorscopes are displayed according to SD or HD input signals.
- 100% and 75% scales are indicated on the Vectorscope.rm.

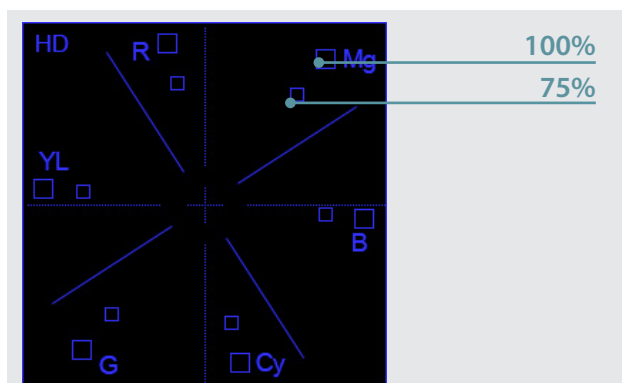
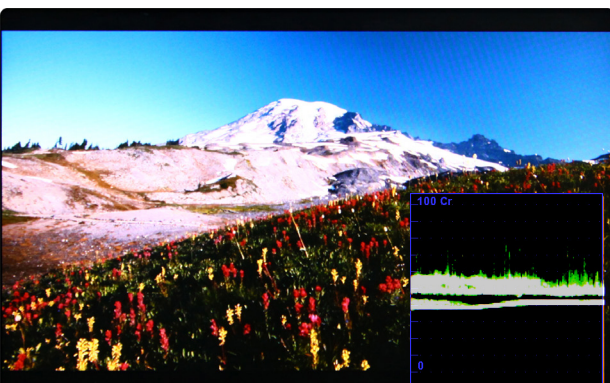

07 OTHER FUNCTIONS

[3] LINE SELECT (WAVEFORM/VECTORSCOPE)

- Used to select specific Vertical Line for WaveForm/VectorScope.

- This is available when LINE WaveForm is activated.
- To activate this feature, go to [Waveform]-[Waveform/Vector]-[Line Waveform]-[Select Line Position] and use the Knob to select a vertical line.
- Selected line is indicated in White on the screen.
- Control range varies according to the resolution of the input SDI signal.
 - * PAL : 0~625
 - * NTSC : 0~525
 - * 720p : 0~750
 - * 1080 i/p : 0~1125
- * Selected line is indicated on the screen.

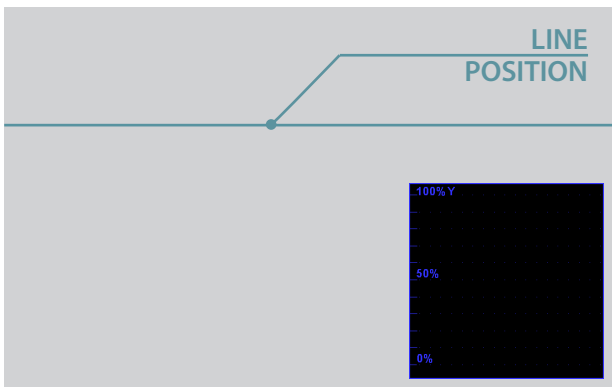

07 OTHER FUNCTIONS

[4] ZOOM

- Used to magnify the input signal from 0% to 90%.
 - Supports Zoom Width Scroll / Zoom Height Scroll function.
 - Zooms IN/OUT focused on the scrolled area.



<ZOOM OFF>



<ZOOM 50%>



<ZOOM 75%>

07 OTHER FUNCTIONS

[5] LUMA (Y') ZONE CHECK

• COLOR PATTERN TYPE

- Displays the Luma(Y') level of the input image in colors.
- $Y' \geq 100\%$: Pixels with higher Y' level than 100 turn to red.
- $Y' \leq 0\%$: Pixels with lower Y' level than 0 turn to green.
- Pixels with Y' levels designated by the user are displayed in following colors - yellow, pink, cyan.
- Factory Default Y' (Border line between pink and yellow) level is 75% and the pink color is assigned to pixels with Y' level from 70% to 75%.
- Yellow color is assigned to pixels with Y' level from 75% to 85%, and Cyan from 60% to 70%.
- This function is designed for a better performance in setting the exposure when shooting with DSLR cameras.

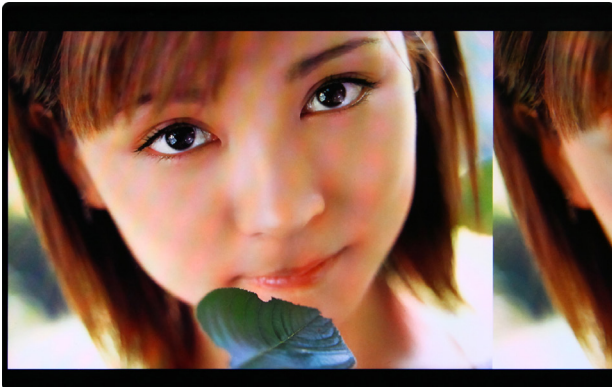

<Luma Zone Check OFF>

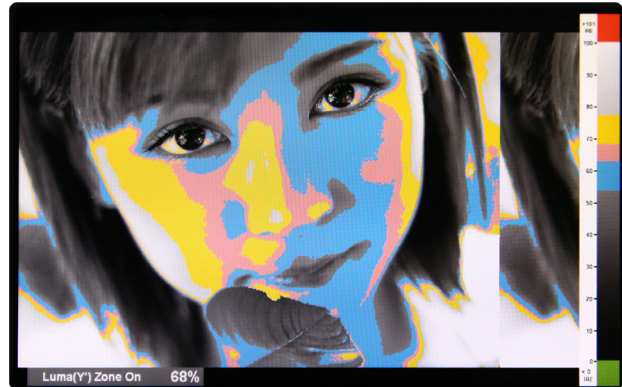

<Luma Zone Check ON_Color Pattern Type>

• ZEBRA PATTERN TYPE

- Displays the pixels with designated Luma(Y') levels with zebra pattern.
- $Y' \geq 100\%$: Pixels with Y' level over 100% turn to red diagonal stripes.
- $Y' \leq 0\%$: Pixels with Y' level under 0% turn to green diagonal stripes.
- User defined Y' levels are displayed as black diagonal stripes.
- Factory Default Y' level is 70% and the pixels with Y' level from 65% to 75% is displayed with zebra pattern.
- Pixels with 10% of Y' level is displayed as black diagonal stripes.
- This function is designed for a better performance in setting the exposure when shooting with DSLR cameras.

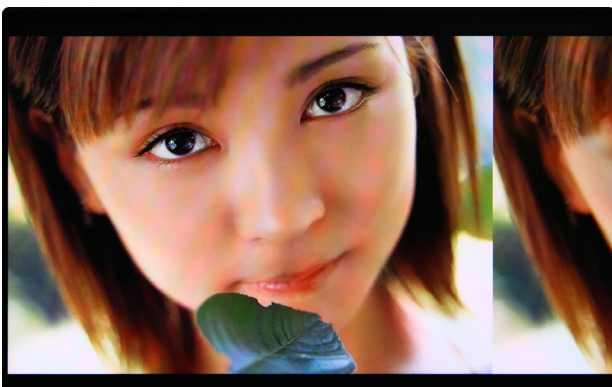

<Luma Zone Check OFF>

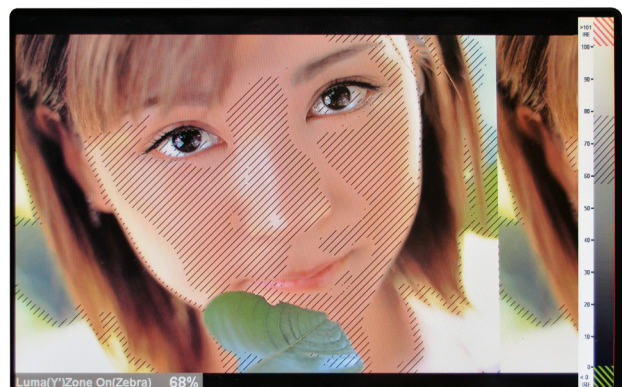

<Luma Zone Check ON_Zebra Pattern Type>

07 OTHER FUNCTIONS

[6] FOCUS ASSIST

- **Focus Assist function assigns a color to the pixels in the shape or the boundary of the image to inform the user to achieve the best focus.**

- With this function, user can easily differentiate the focused area from the out-focused area especially when shooting with a shallow depth of field.
- Available types are [Mono] and [Color] types.
- * [Mono] : Background image is mono type.
- * [Color] : Background image is original color type.



<Focus Assist ON>



<Focus Assist Mono ON>

07 OTHER FUNCTIONS

[7] RANGE ERROR

- Pixels with Y' or C' levels exceeding the designated levels of Y MAX, Y MIN, C MAX and C MIN shall blink.
- Analyzes the input signal's Luma(Y') and chroma information(C') and if the input signal exceeds the designated minimum value and maximum value, the pixel shall blink. This function is to help the user to easily find out any unwanted level of signals and for a better exposure setting.
- * In the case of RGB input, Range Error is not supported.

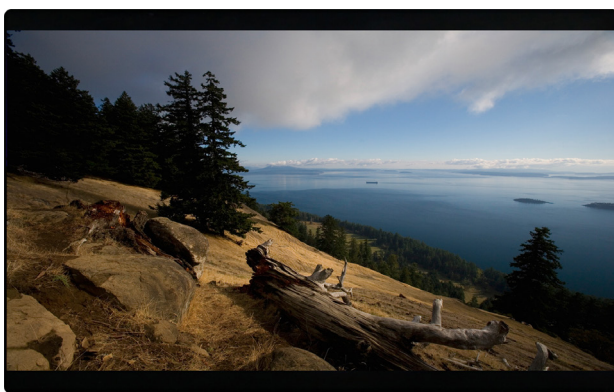

<Range Error OFF>

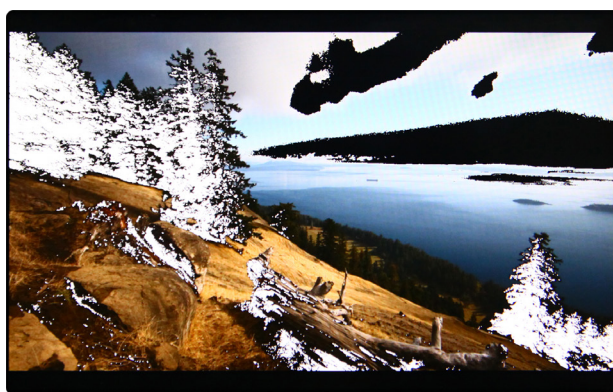

<Range Error ON>

07 OTHER FUNCTIONS

[8] HDMI To SDI SDI To HDMI CONVERSION-OUT / SDI To HDMI CONVERSION-OUT

HDMI TO SDI CONVERSION-OUT

- Video source from 'HDMI input' terminal can be output through 'SDI throughout' terminal.

Input Format	Output Format	
	1080p50	1080p60
480i(NTSC)		•
576i(PAL)	•	
480P		•
576P	•	
720P50	•	
720P59.94		•
720P60		•
1080i50	•	
1080i59.94		•
1080i60		•
1080p24		•
1080p25	•	
1080p30		•
1080psF24		•
1080p50	•	
1080p59.94		•
1080p60		•

SDI TO HDMI CONVERSION-OUT

- 3G/HD/SD SDI signals from 'SDI input' terminal can be output through 'HDMI out' terminal.

Input Format	Output Format	
	1080p50	1080p60
480i(NTSC)		•
576i(PAL)	•	
720P50	•	
720P59.94		•
720P60		•
1080i50	•	
1080i59.94		•
1080i60		•
1080p24		•
1080p25	•	
1080p30		•
1080psF24		•
1080p50	•	
1080p59.94		•
1080p60		•

- ※ Note : HD SLR camera manufacturers usually specify the resolution and frame rate for the recording. The signal format that is output through HDMI terminal of cameras may differ from makers to makers. The signal format for HDMI output and playback function of Canon HD SLRs is 59.94i. And even though 60i or 60p is specified in the specification of the cameras, the actual recording or HDMI output format would be 59.94i or 59.94p.

07 OTHER FUNCTIONS

[9] INTERNAL PATTERN

- **Displays internally generated test patterns.**

- The pattern consists of ColorBar and Pluge+ Grayscale Patterns. Full screen colors of various gray levels (0~100%) are also embedded.

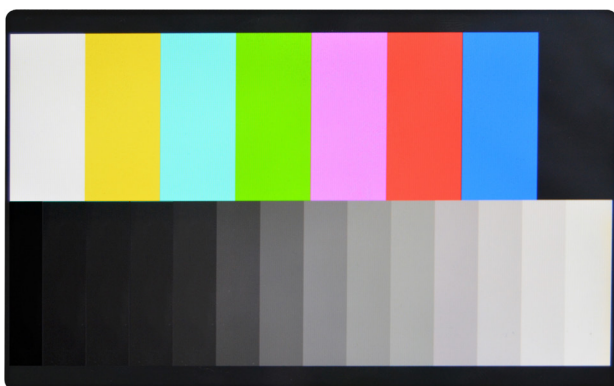

<Color Bar + Pluge Pattern>



<Gray Pattern>

07 OTHER FUNCTIONS

[10] FIRMWARE UPGRADE

- **The USB(Thumb drive) which contains the F/W file is needed for Firmware Upgrade.**
- **Select the SW UPGRADE in the SYSTEM menu.**
 1. Connect the USB to the USB Slot on the bottom of the monitor.
 2. Select what to update among CPU / FPGA / ALL in [S/W UPGRADE].
 3. When the USB connection is completed, the S/W upgrade starts and the progress displays on the bottom left side of the screen.
 4. If the USB doesn't connect properly or there is no file in the specified location, the error message will be displayed on the bottom left side of the screen and the upgrade won't start.
 5. In that case, check the USB or the file location and try again.
- **After USB connection, turn off and then on the monitor.**

07 OTHER FUNCTIONS

[11] Import and Apply 3D LUT Files

- **USB Flash Drive's file system: FAT32**
- **Supported 3D LUT Format: cube**
- **LUT Size: 17 x 17 x 17 and 33 x 33 x 33**
- **Length of 3D LUT file: up to 20 characters including the extension**

1. Create a new folder in the USB Flash drive and name it '3DLUT'
Note: All capital letters, No space. Do not create the folder name like "3D LUT" or "3d lut" or "3D_LUT".
2. Insert the LUT files into the '3DLUT' folder.
Note: The file name must not exceed 20 characters including the extension.
3. Plug in the USB Flash Drive into the monitor.
4. Go to [3D LUT Sync] menu and hit [Sync Active].
5. After the 3D LUT files loading is finished, the file names will appear. Then, assign the desired LUT files to [Import 1], [Import 2], and [Import 3], respectively.
6. Select the desired LUT file to load in [3D LUT Load] menu.

08 AVAILABLE SIGNAL FORMATS

	INPUT SIGNAL	DISPLAY CHARACTER EXAMPLE	SDI	HDMI
VIDEO	480 / 59.94i (NTSC)	720x480 60i	•	•
	480 / 60p	720x480 60p		•
	576 / 50i (PAL)	720x576 50iW	•	•
	576 / 50p	720x576 50p		•
	720 / 23.98p	1280x720 24p	•	
	720 / 24p	1280x720 24p	•	
	720 / 25p	1280x720 25p	•	
	720 / 30p	1280x720 30p	•	
	720 / 50p	1280x720 50p	•	•
	720 / 59.94p	1280x720 60p	•	•
	720 / 60p	1280x720 60p	•	•
	1080 / 23.98PsF	1920x1080 48i	•	
	1080 / 24PsF	1920x1080 48i	•	
	1080 / 25PsF	1920x1080 50i	•	
	1080 / 23.98p	1920x1080 24p	•	•
	1080 / 30PsF	1920x1080 60i	•	
	1080 / 29.97PsF	1920x1080 60i	•	
	1080 / 24p	1920x1080 24p	•	•
	1080 / 25p	1920x1080 25p	•	•
	1080 / 29.97p	1920x1080 30p	•	•
1080 / 30p	1920x1080 30p	•	•	
1080 / 50i	1920x1080 50i	•	•	
1080 / 50p	1920x1080 25p	•	•	
1080 / 59.94i	1920x1080 60i	•	•	
1080 / 60i	1920x1080 60i	•	•	
1080 / 59.94p	1920x1080 60p	•	•	
1080 / 60p	1920x1080 60p	•	•	
PC	640 x 400 (70Hz)	640x400 70p		•
	640 x 480 (60Hz)	640x480 60p		•
	640 x 480 (75Hz)	640x480 75p		•
	800 x 600 (60Hz)	800x600 60p		•
	800 x 600 (75Hz)	800x600 75p		•
	1024 x 768 (60Hz)	1024x768 60p		•
	1024 x 768 (70Hz)	1024x768 70p		•
	1024 x 768 (75Hz)	1024x768 75p		•
	1280 x 768 (60Hz)	1280x768 60p		•
	1280 x 800 (60Hz)	1280x800 60p		•
	1280 x 1024 (60Hz)	1280x1024 60p		•
	1920 x 1080 (60Hz)	1920x1080 60p		•

09 VIDEO SUPPORT RESOLUTION

INPUT SIGNAL INTERFACES	SIGNAL FORMAT (SD SDI)	
SD SDI single link	720x487 (59.94i) 720x576 (50i)	YCbCr 4:2:2 10bit
INPUT SIGNAL INTERFACES	SIGNAL FORMAT (HD SDI)	
HD SDI single link	1280x720 (50/59.94/60P) 1920x1080 (23.98/24/25/29.97/30p) (50/59.94/60i) (24/25/29.97/30psf)	YCbCr 4:2:2 10bit
INPUT SIGNAL INTERFACES	SIGNAL FORMAT (3G SDI)	
3G-SDI (A/B) single link	1920x1080 (60p/59.94p/50p)	YCbCr 4:2:2 10bit
	1920x1080 (30/29.97/25/24/23.98/ 30sF/29.97sF/25sF/24sF/23.98sF) 1920x1080i (60/59.94/50)	YCbCr 4:2:2 12bit RGB 4:4:4 10bit / 12bit YCbCr 4:4:4 10bit / 12bit
	1280x720 (50/59.94/60P)	RGB 4:4:4 10bit YCbCr 4:4:4 10bit
	2048x1080 (60/59.94/50/30/29.97/25/24/23.98 30sF/29.97sF/25sF/24sF/23.98sF)	RGB 4:4:4 8bit / 10bit / 12bit YCbCr 4:4:4 8bit / 10bit / 12bit YCbCr 4:2:2 8bit / 10bit / 12bit
INPUT SIGNAL INTERFACES	SIGNAL FORMAT (HDMI / DP)	
HDMI Single link	1080p (60/59.94/50/30/29.97/25/24/23.98) 1080i (60/59.94/50) 720p (50/59.94/60p) 480i(60) / 576i(50) 480p(60) / 576p(50)	RGB 4:4:4 8bit / 10bit / 12bit YCbCr 4:2:2 8bit / 10bit / 12bit YCbCr 4:2:2 8bit / 10bit / 12bit
	1280x720(50/59.94/60p) 1920x1080(50/59.94/60p) 1920x1080(23.98/24/25/29.97/30p,60i/59.94i/50i)	* HDMI RGB 4:4:4 8bit YCbCr 4:4:4 8bit YCbCr 4:2:2 8bit
	3840x2160 (23.98/24/25/29.97/30p/50/59.94/60p)	RGB 4:4:4 8, 10, 12bit YCbCr 4:4:4 8, 10, 12bit YCbCr 4:2:2 8, 10, 12bit YCbCr 4:2:0 8, 10, 12bit
	4096x2160 (23.98/24/25/29.97/30p/50/59.94/60p)	RGB 4:4:4 8, 10, 12bit YCbCr 4:4:4 8, 10, 12bit YCbCr 4:2:2 8, 10, 12bit YCbCr 4:2:0 8, 10, 12bit

10 AVAILABLE SIGNAL FORMATS

* Active Through : same as input format

F-10A OUTPUT VIDEO FORMAT						
Input Video Format		Frame rate	SDI OUT			HDMI OUT
			SDI-OUT PORT	SDI-IN/OUT (CAM LUT OFF)	SDI-IN/OUT (CAM LUT ON)	HDMI
SDI	720 x 480i	59.94	Passive Through	Active Through	1920 x 1080 60p	1920 x 1080 60p
	720 x 576i	50	Passive Through	Active Through	1920 x 1080 50p	1920 x 1080 50p
	1280 x 720p	60/59.94/50	Passive Through	Active Through	Active Through	Active Through
	1280 x 720p	30/29.97	Passive Through	Active Through	Active Through	Active Through
	1280 x 720p	25/24/23.98	Passive Through	Active Through	1920 x 1080 50p	1920 x 1080 50p
	1920 x 1080i	30/29.97/25/24/23.98	Passive Through	Active Through	Active Through	Active Through
	1920 x 1080p	30sF/29.97sF	Passive Through	Active Through	Active Through	1920 x 1080 60p
	1920 x 1080p	25sF/24sF/23.98sF	Passive Through	Active Through	Active Through	1920 x 1080 50p
	1920 x 1080p	60/59.94/50	Passive Through	Active Through	Active Through	Active Through
	1920 x 1080p	30/29.97/25/24/23.98	Passive Through	Active Through	Active Through	Active Through
	2048 x 1080p	60/59.94/50	Passive Through	Active Through	Active Through	Active Through
	2048 x 1080p	30/29.97/25/24/23.98	Passive Through	Active Through	Active Through	Active Through
	2048 x 1080p	30sF/29.97sF/25sF/24sF/23.98sF	Passive Through	Active Through	Active Through	Active Through

HDMI	720 x 480i	59.94	Passive Through	1920 x 1080 60p	1920 x 1080 60p	Active Through
	720 x 576i	50	Passive Through	1920 x 1080 50p	1920 x 1080 50p	Active Through
	720 x 480p	60	Passive Through	1920 x 1080 60p	1920 x 1080 60p	Active Through
	720 x 576p	50	Passive Through	1920 x 1080 50p	1920 x 1080 50p	Active Through
	1280 x 720p	60/59.94/50	Passive Through	Active Through	Active Through	Active Through
	1920 x 1080p	60/59.94/50/30/29.97/25/24	Passive Through	Active Through	Active Through	Active Through
	1920 x 1080i	60/59.94/50	Passive Through	Active Through	Active Through	Active Through
	3840 x 2160p	60/59.94/30/29.97	Passive Through	1920 x 1080 60p	1920 x 1080 60p	1920 x 1080 60p
	3840 x 2160p	50/25/24/23.98	Passive Through	1920 x 1080 50p	1920 x 1080 50p	1920 x 1080 50p
	4096 x 2160p	50/25/24/23.98	Passive Through	1920 x 1080 50p	1920 x 1080 50p	1920 x 1080 50p
	4096 x 2160p	60/59.94/30	Passive Through	1920 x 1080 60p	1920 x 1080 60p	1920 x 1080 60p

11 PRODUCT SPECIFICATIONS

F-10A		
LCD	Size	10"
	Resolution	1920×1080 (16:9)
	Pixel Pitch	0.11475(H) X 0.11475(W) mm
	Color Depth	16.7M
	Viewing Angle (Typ.)	160°(H)/160°(V)
	Luminance of white	300 cd/m ² (Max.)
	Contrast Ratio	1000 : 1
	Display Area	220.3(H)x123.9(V) mm
Input	1 X HDMI	HDMI 2.0 Input
	2 X BNC	3G-SDI * I/O integrated Chip
Output	1 X HDMI	HDMI 1.4 Output 1Ch
	1 X BNC	3G/HD/SD SDI Output 1Ch
Input Signal	3G-SDI	2.970Gbps
	HD-SDI	1.485Gbps
	SD-SDI	270 Mbps
	HDMI	480i / 480p / 576i / 576p / 720p / 1080i / 1080p / 2160p
SDI Input Signal Formats	SMPTE-425M-A/B	1080p(60/59.94/50/30/29.97/25/24/23.98/30sF/29.97sF/25sF/24sF/23.98sF) 1080i(60/59.94/50)
	SMPTE-274M	1080i (60/59.94/50)
		1080p (30/29.97/25/24/24sF/23.98/23.98sF)
	SMPTE-296M	720p (60/59.94/50)
	SMPTE-125M	480i (59.94)
ITU-R BT.656	576i (50)	
Audio In	SDI Embedded Audio (Group, Ch Selectable)	
Audio Out	External Output Port (3.5m Phone Jack)	
Power	DC 6V / 2.5A , 34V / 0.5A	
Power Consumption (Approx.)	14W	
Operating Temperature	0°C to 40°C (32°F to 104°F)	
Storage Temperature	-20°C to 60°C (-4°F to 140°F)	
Main Body Dimensions (mm/inch)	258 x 154 x 29.8(mm) / 10.15 x 6.06 x 1.17(inch)	
Box Dimensions (mm/inch)	320 x 240 x 87(mm) / 12.59x9.44x3.42 (inch)	
Weight	1.3kg / 2.86lbs	
Basic Accessories	BNC Connector, Camera Mount, D-Tap cable	
Optional Accessories	Ball Head, Camera Mount, Battery Bracket, V-mount, G-Mount, HDMI Bracket, Carrying Case, Acrylic Filter	







* The specification above may be changed without notice.

* When using a DC Adapter other than the one supplied by the manufacturer, please be advised that the adapter with DC 12V/3A ~ 6A can be compatible with the monitor.

12 OPTIONAL ACCESSORIES

Model	Product Description	
OPT-AF-F-10	External Acrylic filter F-10A	
Hood-F10	Sun Hood for F-10A	
CC-F10	Aluminum Carrying Case for F-10A	
TH-Mount-F7H	Camera Mount for F-7H / F-7H mk2 (Screw head length 20mm)	
HDMI BKT-F10	HDMI Bracket for F-10A	
AB-mount-F7H (AP) G-Mount-F7H (EMEA)	Anton-Bauer(Gold) Battery Adapter for F-7H / F-7H mk2 / F-10A	

12 OPTIONAL ACCESSORIES

Model	Product Description
D-Tap-C cable	<p>D-Tap Adapter for VFM-056WP, 058W, 055A & LVM-074, 070C, 075A / SRM-074W(-N) / F-7H (Coil Type) / F-7H mk2 / F-10A</p> 
D-Tap-S cable	<p>D-Tap Adapter for VFM-056WP, 058W, 055A & LVM-074, 070C, 075A / SRM-074W(-N) / F-7H (short - 17" length) / F-7H mk2 / F-10A</p> 
D-Tap-L cable	<p>D-Tap Adapter for VFM-056WP, 058W, 055A & LVM-074W, 070C, 075A / SRM-074W(-N) / F-7H (Long - 29" length) / F-7H mk2 / F-10A</p> 
BB-F7H-S	<p>Battery Bracket for F-7H / F-7H mk2 (Sony NP-F770/F970)</p> 
BB-F7H-C	<p>Battery Bracket for F-7H / F-7H mk2 (Canon BP Series)</p> 
BB-F7H-P	<p>Battery Bracket for F-7H / F-7H mk2 / F-10A (Panasonic CGA/VB Series)</p> 

12 OPTIONAL ACCESSORIES

Model	Product Description
BB-F7H-U	Battery Bracket for F-7H / F-7H mk2 / F-10A (Sony BP-U30/U60) 
BB-F7H-E	Battery Bracket for F-7H / F-7H mk2 / F-10A (Canon LP-E6 Series, DSLR EOS 5D/7D) 
BB-F7H-B	Battery Bracket for F-7H / F-7H mk2 / F-10A (Panasonic AF-100) 
V-Mount-F7H-C	Battery Adapter for F-7H / F-7H mk2 / F-10A (Cost effective) 
V-Mount-F7H	Battery Adapter for F-7H / F-7H mk2 / F-10A (IDX V-Mount Plate) 
BH-1	Ball Head for VFM-056W/WP, 055A / F-5A F-7H / F-7H mk2 / F-10A 

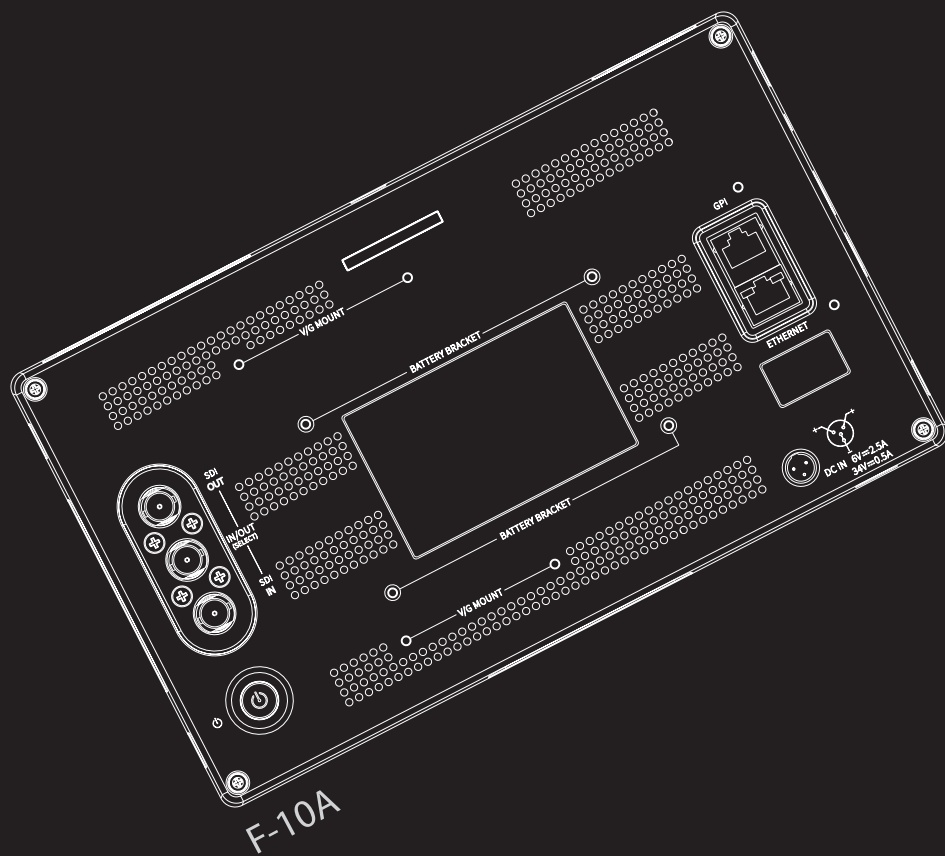

Vidente Co., Ltd. www.tvlogic.tv  tvlogic_official

12F, ACE HIGH-END TOWER 8, 84, Gasan digital 1-ro, Geumcheon-gu, Seoul, 08590, Korea

Tel. +82-70-8668-6611 Fax. +82-2-6123-3201

E-mail. sales@tvlogic.co.kr